

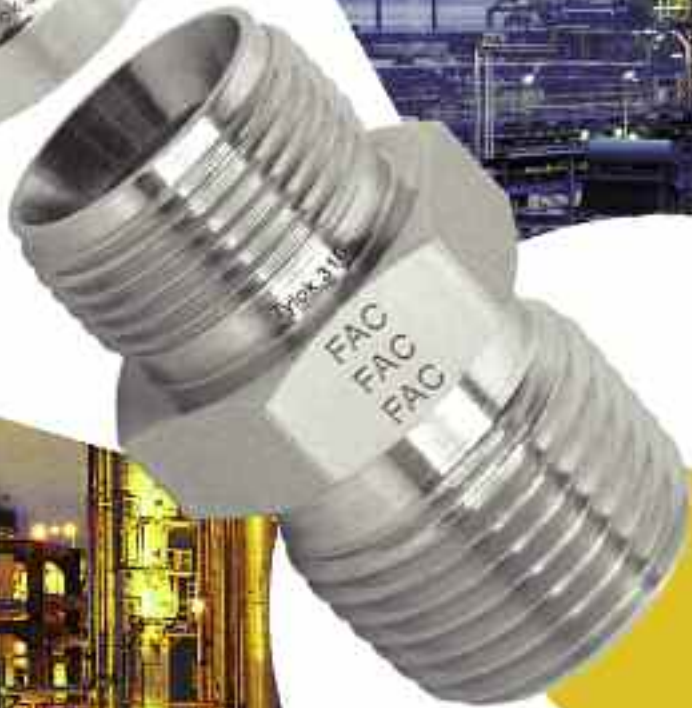

CS-LOK® Tube Fittings



The Tylok Philosophy

Our Mission

It is our mission, at Tylok International, Inc., to continuously strive for and achieve total customer satisfaction with both our products and services.

This objective falls within the framework of the larger movement toward "Total Quality" which is derived of four elements:

1

**Total satisfaction
of our customers**

2

**Make our distributors and
suppliers our partners in
providing the highest quality
products and services**

3

**Create a positive
environment for our
employees that fosters
their full potential**

4

**Continuous financial
success of the company**

We accomplish this by maintaining an honest and ethical business relationship with our customers, suppliers and employees.

Our Goal

Tylok's aggressive goal is to establish ourselves as an industry leader and expand our market share. This is maintained in every department within the organization. Our "total effort" will guard against losing the personal touch that makes our business enjoyable and prosperous for all involved.

Creation of an Industry

In the mid 1940s, Cullen Crawford founded the Crawford Fitting Company. Mr. Crawford developed and patented the original flareless fitting (nut and two ferrule system), for the Crawford Fitting Company. Thus, a new and innovative industry was born making it far easier to make tubing connections. This reduces installation time and errors. Since his invention, End Users from all four corners of the globe have made billions of connections. This system provides leak proof seals and thus Mr. Crawford has been named "The founder of the flareless fitting."

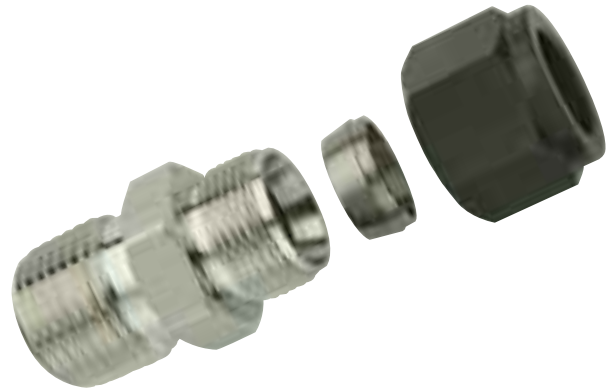

Introduction

Tylok International, Inc. offers a tube fitting line, CS-Lok®, that is fully interchangeable with Parker CPI™. Although it is always recommended to use all CS-Lok® components, intermixing CS-Lok® bodies and/or component parts with that of other manufacturers will not adversely affect sealing ability. CS-Lok® Tube Fittings are made to strict quality control standards and cannot guarantee that of other manufacturers. CS-Lok® Tube Fittings are proudly made in the U.S.A.

Operation

CS-Lok® Tube Fittings are comprised of three components: The Body, Single Ferrule (Collet) and Nut. A leak proof seal is obtained through proper ferrule action as the ferrule is tightened onto the tubing via axial thrust provided by the nut. The ferrule provides the leak proof seal, when the nut and ferrule are properly drawn up the specified number of turns. The stainless steel nuts have a molybdenum disulfide coating, reducing torque and ensuring proper sealing.

Ty-Cor™ Process

Ty-Cor™ refers to the treatment which diffuses carbon into the surface of the stainless steel, thereby increasing the surface hardness without affecting the quality of the metal treated. In fact, when AISI 316 stainless steel is treated, the corrosion resistance is equal to or better than non-treated 316 stainless steel. The increase in corrosion resistance to pitting and stress corrosion is very pronounced in media which contain chlorides (e.g. sea water, bleach, HCl, etc.). The Ty-Cor™ process applied to the ferrule also helps eliminate galling and ensures proper sealing on tube end make ups.

Features

- Single ferrule swaging action
- Total component interchangeability
- More tolerant of vibrations
- Heat Code traceable
- ASTM material construction
- Corrosion resistant 316 Stainless Steel ferrule

Technical Support & Training

Tylok International, Inc. ensures all of its Distributors are trained on the proper installation of compression fittings, tubing selection & preparation. Tylok Distributors are trained to provide the technical support you deserve. Additionally, our Distributors will help in finding solutions for specific applications. Contact your local Tylok Distributor for further information.

Quality Management System

QMI has registered Tylok International's Quality Management System to ISO 9001:2008. The quality system complies with the international standard ISO 9001:2008 and its technical equivalent, ANSI/ISO/ASQ Q9001:2008. Tylok strives to continuously improve the effectiveness of the Quality Management System by each member within the organization. CS-Lok Canadian Registration Number (CRN) is 0A6357.452367890TYN.



ISO 9001

ISO 9001:2008
Certificate No.012106

Table of Contents/Product Locator

HOW TO ORDER

How To Order

4



SATPF

Adapter Tube to Female Pipe

5



SATPM

Adapter Tube to Male Pipe

6



SBHA

Bulkhead Adapter

7



SBHFP

Bulkhead Female Pipe Connector

8



SBHMP

Bulkhead Male Pipe Connector

9

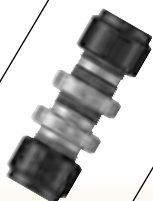

SBHU
Bulkhead Union

10



SBUANF
Bulkhead to AN Flare Union

10



SCAP
Cap

11

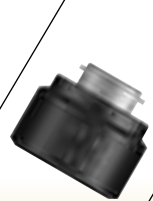

SF PLUG
Fitting Plug

11



SFC
Female Connector

12



SMC
Male Connector

13 & 14



SMC-ORS
O-Ring Straight Thread Male Conn.

15



SMC-ORT
O-Ring Pipe Thread Male Conn.

16



SPCU
Port Connector Union

17



SRATT
Reducer Adapter Tube to Tube

18



SRPC
Reducing Port Connector

19



SRU
Reducing Union

20



STBW
Tube to Butt Weld Connector

21



STSW
Tube to Socket Weld Connector

22



SU
Union

23



SUANF
Tube to AN Flare Union

24



SELU
Union Elbow

25



SFE
Female Elbow

26

Table of Contents/Product Locator



SME
Male Elbow

27 & 28



STBWE
Tube to Butt
Weld Elbow

29



STSWE
Tube to
Socket Weld
Elbow

30



STFT
Female Run
Tee

31

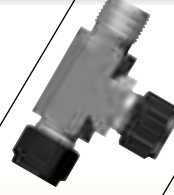

STMT
Male Run
Tee

32



STTF
Female
Branch Tee

33

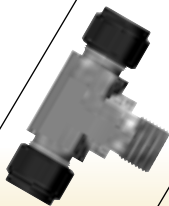

STTM
Male
Branch Tee

34

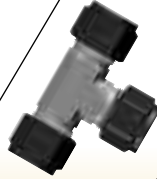

STTT
Union Tee

35



SCR
Union Cross

36

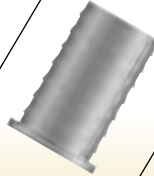

SBI
Barbed
Insert

37

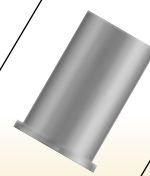

SPI
Plane
Insert

38



SN
Nut

39

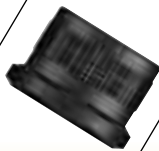

SKN
Knurled Nut

39

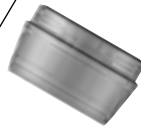

SC
Single Collet
(Ferrule)

40

**COMPONENT
REPLACEMENT
PARTS**

Replacement
Parts

40

**SPECIAL
PRODUCTS**

Special
Products

41

**CS-LOK®
INSTALLATION
INSTRUCTIONS**

Installation
Instructions

42

**CS-LOK® TUBING
SELECTION &
PREPARATION**

Tubing
Selection &
Preparation

43

**GAS SERVICE/
SAFETY/
QUALITY**

Gas Service/
Safety/
Quality

44

**TECHNICAL
DATA**

Technical
Data

45

**TRACEABILITY/
MATERIAL SPEC./
PRE-SET TOOL**

Heat
Traceability/
Mat'l Spec./
Pre-Set Tool

46

**TUBE INSERTION
CHART/
APPLICATIONS**

Tube Insertion
Chart/
Applications

47

**WARRANTY
INFORMATION**

Warranty
Information

48

How to Order CS-LOK® Tube Fittings

CS-Lok® Tube Fittings are ordered as listed in this catalog by inserting the material code before the part number. CS-Lok® Tube Fittings can be identified through the part number as to material, tube size, configuration and thread connection. The part number describes a complete fitting assembly. The size nomenclature to describe a tee fitting is from left (1) to right (2) and down (3). Special Configurations available upon request.

Example: A Stainless Steel Female Run Tee, 3/8" Tube Size to 1/4" Female Pipe to 3/8" Tube is designated as follows.

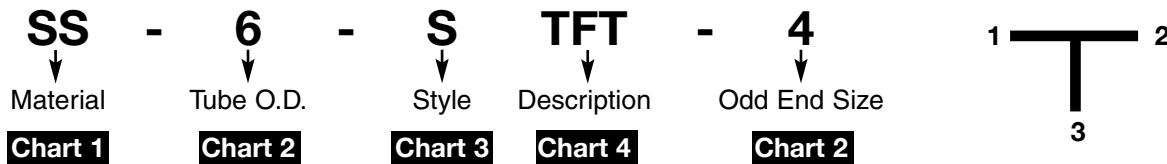

Chart 1 - Material

SS	Stainless Steel
B	Brass
S	Steel

Chart 3 - Style

S	CS-Lok®
---	---------

Chart 2 - Tube O.D.

Designator	Tube or Hose OD (inches)	Pipe Thread (NPT)	AN Tube Flare Size (inches)	Pipe Thread BSPP/BSPT
1	1/16	1/16-27		1/16-28
2	1/8	1/8-27	1/8	1/8-28
3	3/16		3/16	
4	1/4	1/4-18	1/4	1/4-19
5	5/16		5/16	
6	3/8	3/8-18	3/8	3/8-19
8	1/2	1/2-14	1/2	1/2-14
10	5/8		5/8	
12	3/4	3/4-14	3/4	3/4-14
14	7/8		7/8	
16	1	1.0-11 1/2	1	1.0-11

Chart 4 - Description

SATPF	Adapter Tube to Female Pipe
SATPM	Adapter Tube to Male Pipe
SBHA	Bulkhead Adapter
SBHFP	Bulkhead Female Pipe Connector
SBHMP	Bulkhead Male Pipe Connector
SBHU	Bulkhead Union
SBUANF	Bulkhead to AN Flare Union
SCAP	Cap
SF PLUG	Fitting Plug
SFC	Female Connector
SMC	Male Connector
SMC-ORS	O Ring Straight Thread Male Connector
SMC-ORT	O Ring Pipe Thread Male Connector
SPCU	Port Connector Union
SRATT	Reducer Adapter Tube to Tube
SRPC	Reducing Port Connector
SRU	Reducing Union
STBW	Tube to Butt Weld Connector
STSW	Tube to Socket Weld Connector

SU	Union
SUANF	Tube to AN Flare Union
SELU	Union Elbow
SFE	Female Elbow
SME	Male Elbow
STBWE	Tube to Butt Weld Elbow
STSWE	Tube to Socket Weld Elbow
STFT	Female Run Tee
STMT	Male Run Tee
STTF	Female Branch Tee
STTM	Male Branch Tee
STTT	Union Tee
SCR	Union Cross
SBI	Barbed Insert
SPI	Plane Insert
SN	Nut
SKN	Knurled Nut
SC	Single Collet (Ferrule)

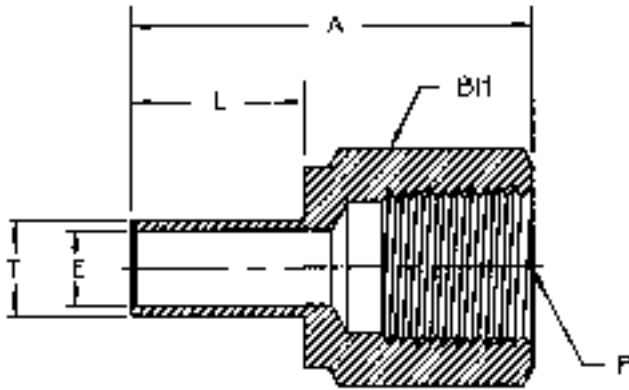

Adapter Tube to Female Pipe

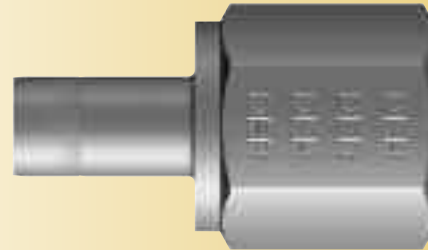

PART NUMBER	INTERCHANGES WITH	T TUBE O.D.	P PIPE END NPT	A	E THRU HOLE	L	BH BODY HEX
2-SATPF-2	2-2 T2HG	1/8	1/8	1.234	.078	.562	9/16
2-SATPF-4	2-4 T2HG	1/8	1/4	1.406	.078	.562	3/4
3-SATPF-2	3-2 T2HG	3/16	1/8	1.281	.125	.609	9/16
3-SATPF-4	3-4 T2HG	3/16	1/4	1.453	.125	.609	3/4
4-SATPF-2	4-2 T2HG	1/4	1/8	1.312	.156	.640	9/16
4-SATPF-4	4-4 T2HG	1/4	1/4	1.484	.156	.640	3/4
4-SATPF-6	4-6 T2HG	1/4	3/8	1.500	.156	.640	7/8
4-SATPF-8	4-8 T2HG	1/4	1/2	1.812	.156	.640	1-1/16
5-SATPF-2	5-2 T2HG	5/16	1/8	1.390	.219	.687	9/16
5-SATPF-4	5-4 T2HG	5/16	1/4	1.516	.219	.687	3/4
6-SATPF-2	6-2 T2HG	3/8	1/8	1.359	.281	.718	9/16
6-SATPF-4	6-4 T2HG	3/8	1/4	1.547	.281	.718	3/4
6-SATPF-6	6-6 T2HG	3/8	3/8	1.594	.281	.718	7/8
6-SATPF-8	6-8 T2HG	3/8	1/2	1.843	.281	.718	1-1/16
8-SATPF-4	8-4 T2HG	1/2	1/4	1.828	.375	.984	3/4
8-SATPF-6	8-6 T2HG	1/2	3/8	1.890	.375	.984	7/8
8-SATPF-8	8-8 T2HG	1/2	1/2	2.140	.375	.984	1-1/16
10-SATPF-6	10-6 T2HG	5/8	3/8	1.937	.468	1.031	7/8
10-SATPF-8	10-8 T2HG	5/8	1/2	2.187	.468	1.031	1-1/16
12-SATPF-8	12-8 T2HG	3/4	1/2	2.187	.578	1.031	1-1/16
14-SATPF-12	14-12 T2HG	7/8	3/4	2.265	.687	1.078	1-1/4
16-SATPF-12	16-12 T2HG	1	3/4	2.484	.812	1.296	1-1/4
16-SATPF-16	16-16 T2HG	1	1	2.828	.812	1.296	1-5/8

*NOTE: All dimensions subject to change, to be used for reference only.

Adapter Tube to Male Pipe

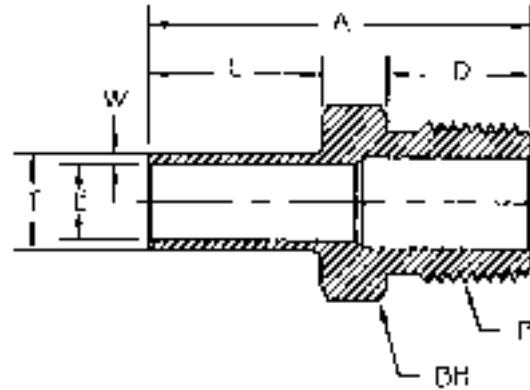

PART NUMBER	INTERCHANGES WITH	T TUBE O.D.	P PIPE END NPT	A	D	E ¹ THRU HOLE	L	W	BH BODY HEX
2-SATPM-2	2-2 T2HF	1/8	1/8	1.187	.375	.078	.562	.023	7/16
2-SATPM-4	2-4 T2HF	1/8	1/4	1.406	.562	.078	.562	.023	9/16
3-SATPM-2	3-2 T2HF	3/16	1/8	1.234	.375	.125	.609	.031	7/16
3-SATPM-4	3-4 T2HF	3/16	1/4	1.453	.562	.125	.609	.031	9/16
4-SATPM-2	4-2 T2HF	1/4	1/8	1.265	.375	.156	.640	.047	7/16
4-SATPM-4	4-4 T2HF	1/4	1/4	1.484	.562	.156	.640	.047	9/16
4-SATPM-6	4-6 T2HF	1/4	3/8	1.500	.562	.156	.640	.047	11/16
4-SATPM-8	4-8 T2HF	1/4	1/2	1.718	.750	.156	.640	.047	7/8
5-SATPM-2	5-2 T2HF	5/16	1/8	1.297	.375	.219	.687	.047	7/16
5-SATPM-4	5-4 T2HF	5/16	1/4	1.516	.562	.219	.687	.047	9/16
6-SATPM-2	6-2 T2HF	3/8	1/8	1.343	.375	.187	.718	.047	7/16
6-SATPM-4	6-4 T2HF	3/8	1/4	1.562	.562	.281	.718	.047	9/16
6-SATPM-6	6-6 T2HF	3/8	3/8	1.609	.562	.281	.718	.047	11/16
6-SATPM-8	6-8 T2HF	3/8	1/2	1.812	.750	.281	.718	.047	7/8
8-SATPM-4	8-4 T2HF	1/2	1/4	1.828	.562	.281	.984	.062	9/16
8-SATPM-6	8-6 T2HF	1/2	3/8	1.859	.562	.375	.984	.062	11/16
8-SATPM-8	8-8 T2HF	1/2	1/2	2.078	.750	.375	.984	.062	7/8
10-SATPM-6	10-6 T2HF	5/8	3/8	1.906	.562	.375	1.031	.078	11/16
10-SATPM-8	10-8 T2HF	5/8	1/2	2.125	.750	.468	1.031	.078	7/8
10-SATPM-12	10-12 T2HF	5/8	3/4	2.125	.750	.468	1.031	.078	1-1/16
12-SATPM-8	12-8 T2HF	3/4	1/2	2.125	.750	.468	1.031	.086	7/8
12-SATPM-12	12-12 T2HF	3/4	3/4	2.125	.750	.578	1.031	.086	1-1/16
12-SATPM-16	12-16 T2HF	3/4	1	2.406	.937	.578	1.031	.086	1-3/8
14-SATPM-12	14-12 T2HF	7/8	3/4	2.172	.750	.687	1.078	.094	1-3/8
16-SATPM-12	16-12 T2HF	1	3/4	2.390	.750	.625	1.296	.094	1-1/16
16-SATPM-16	16-16 T2HF	1	1	2.687	.937	.812	1.296	.094	1-3/8

*NOTE: All dimensions subject to change, to be used for reference only.

¹ The E dimension is the minimum opening. These fittings may have a larger opening at the pipe/straight thread end.

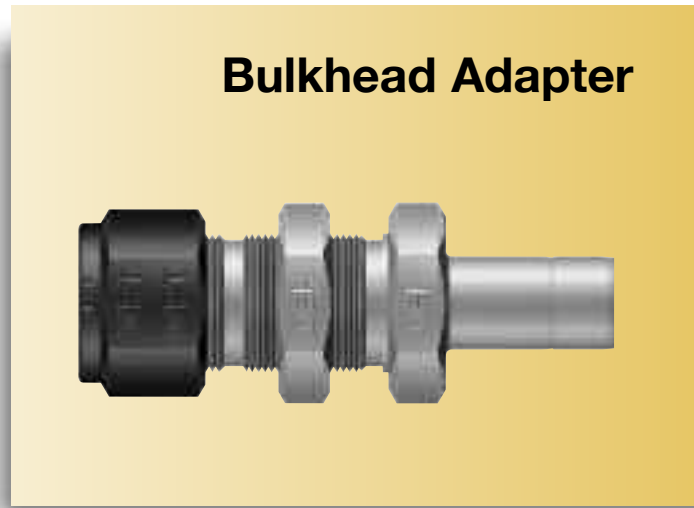
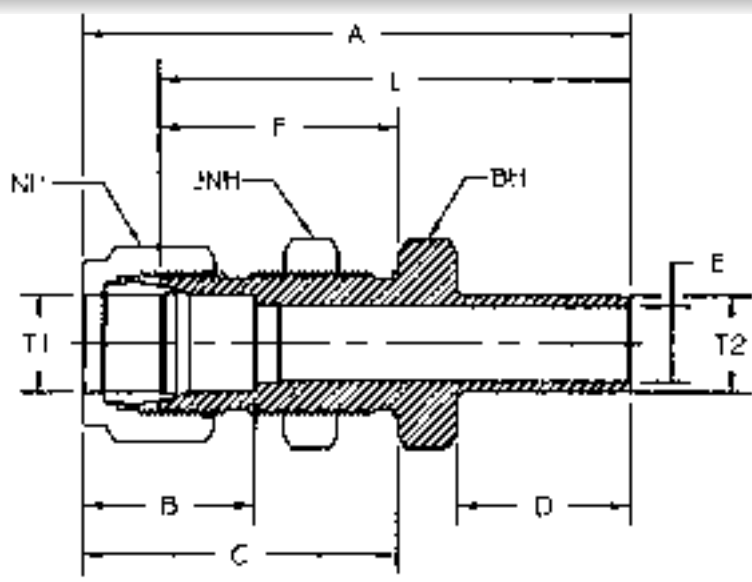

PART NUMBER	INTERCHANGES WITH	T1 TUBE O.D.	T2 TUBE O.D.	A	B	C	D	E THRU HOLE	F	L	NH NUT HEX	JNH JAM NUT HEX	BH BODY HEX	PANEL HOLE
2-SBHA-2	2-2 T2H2BZ	1/8	1/8	2.000	.500	1.234	.562	.078	.969	1.234	7/16	1/2	1/2	21/64
4-SBHA-4	4-4 T2H2BZ	1/4	1/4	2.203	.609	1.328	.640	.156	1.031	1.906	9/16	5/8	5/8	29/64
6-SBHA-6	6-6 T2H2BZ	3/8	3/8	2.437	.656	1.453	.718	.281	1.156	2.156	11/16	3/4	3/4	37/64
8-SBHA-8	8-8 T2H2BZ	1/2	1/2	2.953	.906	1.656	.984	.375	1.250	2.547	7/8	15/16	15/16	49/64

*NOTE: All dimensions subject to change, to be used for reference only.

Bulkhead Female Pipe Connector

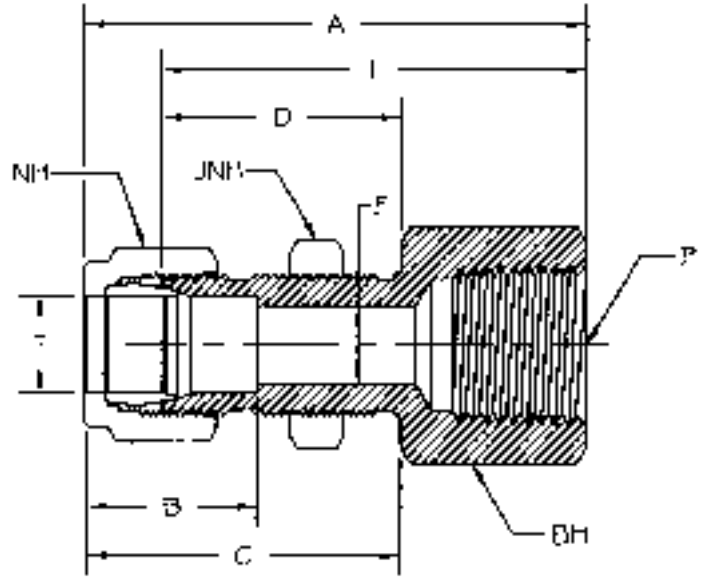
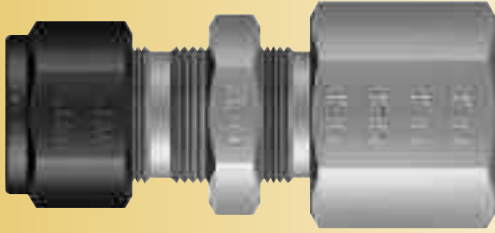

PART NUMBER	INTERCHANGES WITH	T TUBE O.D.	P PIPE END NPT	A	B	C	D	E THRU HOLE	L	NH NUT HEX	JNH JAM NUT HEX	BH BODY HEX	PANEL HOLE
2-SBHFP-2	2-2 GH2BZ	1/8	1/8	1.766	.500	1.234	.969	.094	1.500	7/16	1/2	9/16	21/64
3-SBHFP-2	3-2 GH2BZ	3/16	1/8	1.797	.547	1.266	1.000	.125	1.531	1/2	9/16	9/16	25/64
4-SBHFP-2	4-2 GH2BZ	1/4	1/8	1.859	.609	1.328	1.031	.187	1.562	9/16	5/8	5/8	29/64
4-SBHFP-4	4-4 GH2BZ	1/4	1/4	2.047	.609	1.328	1.031	.187	1.750	9/16	5/8	3/4	29/64
5-SBHFP-2	5-2 GH2BZ	5/16	1/8	1.969	.641	1.422	1.125	.250	1.656	5/8	3/4	11/16	33/64
6-SBHFP-4	6-4 GH2BZ	3/8	1/4	2.172	.656	1.453	1.156	.281	1.875	11/16	3/4	3/4	37/64
8-SBHFP-6	8-6 GH2BZ	1/2	3/8	2.437	.906	1.656	1.250	.406	2.031	7/8	15/16	15/16	49/64
8-SBHFP-8	8-8 GH2BZ	1/2	1/2	2.625	.906	1.656	1.250	.406	2.219	7/8	15/16	1-1/16	49/64
10-SBHFP-8	10-8 GH2BZ	5/8	1/2	2.656	.969	1.687	1.281	.500	2.250	1	1-1/16	1-1/16	57/64
16-SBHFP-16	16-16 GH2BZ	1	1	3.687	1.234	2.266	1.781	.875	3.187	1-1/2	1-1/2	1-5/8	1-21/64

*NOTE: All dimensions subject to change, to be used for reference only.

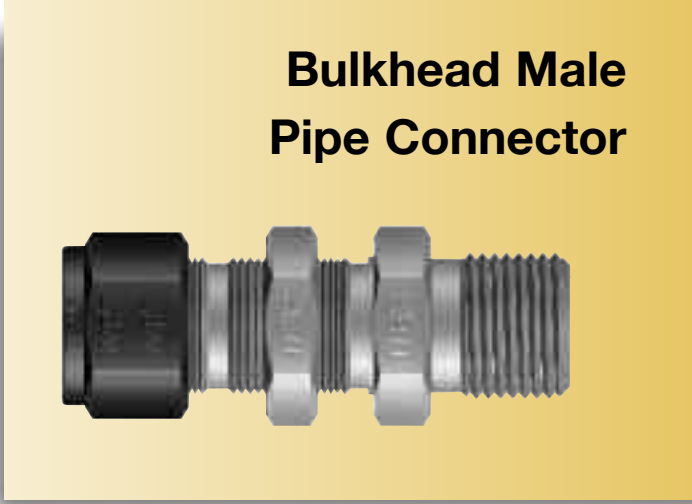
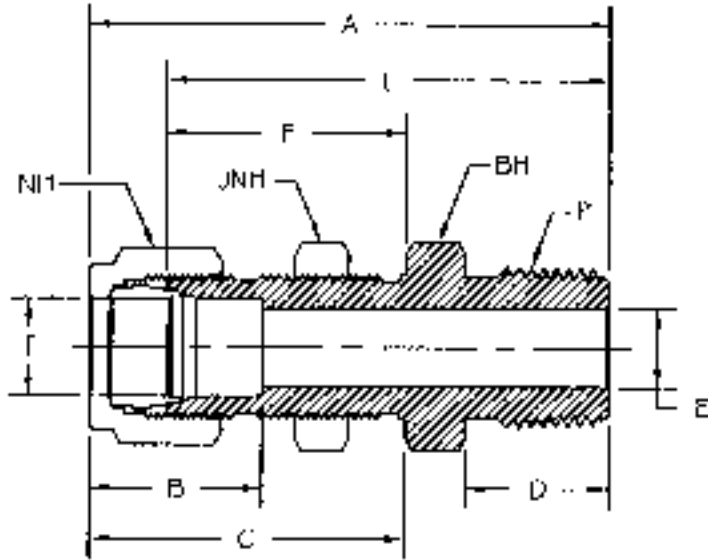

PART NUMBER	INTERCHANGES WITH	T TUBE O.D.	P PIPE END NPT	A	B	C	D	E ¹ THRU HOLE	F	L	NH NUT HEX	JNH JAM NUT HEX	BH BODY HEX	PANEL HOLE
1-SBHMP-1	1-1 FH2BZ	1/16	1/16	1.187	.437	.687	.375	.052	.531	1.031	5/16	7/16	5/16	13/64
1-SBHMP-2	1-2 FH2BZ	1/16	1/8	1.234	.437	.687	.375	.052	.531	1.094	5/16	7/16	7/16	13/64
2-SBHMP-2	2-2 FH2BZ	1/8	1/8	1.828	.500	1.234	.375	.094	.969	1.578	7/16	1/2	1/2	21/64
3-SBHMP-2	3-2 FH2BZ	3/16	1/8	1.859	.547	1.266	.375	.125	1.000	1.594	1/2	9/16	9/16	25/64
4-SBHMP-2	4-2 FH2BZ	1/4	1/8	1.953	.609	1.328	.375	.187	1.031	1.656	9/16	5/8	5/8	29/64
4-SBHMP-4	4-4 FH2BZ	1/4	1/4	2.109	.609	1.328	.562	.187	1.031	1.843	9/16	5/8	5/8	29/64
4-SBHMP-6	4-6 FH2BZ	1/4	3/8	2.187	.609	1.328	.562	.187	1.016	1.891	9/16	5/8	11/16	29/64
4-SBHMP-8	4-8 FH2BZ	1/4	1/2	2.484	.609	1.328	.562	.187	1.016	2.187	9/16	5/8	7/8	29/64
6-SBHMP-4	6-4 FH2BZ	3/8	1/4	2.266	.656	1.453	.562	.281	1.156	1.969	11/16	3/4	3/4	37/64
6-SBHMP-6	6-6 FH2BZ	3/8	3/8	2.312	.656	1.437	.562	.281	1.156	1.969	11/16	3/4	3/4	37/64
6-SBHMP-8	6-8 FH2BZ	3/8	1/2	2.609	.656	1.437	.750	.281	1.156	2.312	11/16	3/4	7/8	37/64
8-SBHMP-4	8-4 FH2BZ	1/2	1/4	2.547	.906	1.656	.562	.281	1.250	2.141	7/8	15/16	15/16	49/64
8-SBHMP-6	8-6 FH2BZ	1/2	3/8	2.484	.906	1.656	.562	.375	1.250	2.094	7/8	15/16	15/16	49/64
8-SBHMP-8	8-8 FH2BZ	1/2	1/2	2.719	.906	1.656	.750	.406	1.250	2.312	7/8	15/16	15/16	49/64

*NOTE: All dimensions subject to change, to be used for reference only.

¹ The E dimension is the minimum opening. These fittings may have a larger opening at the pipe/straight thread end.

Bulkhead Union

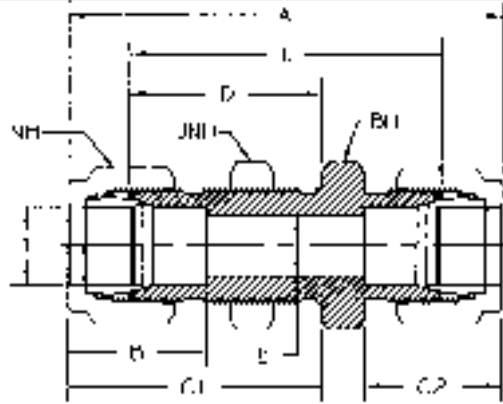
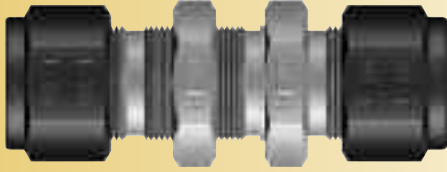

PART NUMBER	INTERCHANGES WITH	T TUBE O.D.	A	B	C1	C2	D	E THRU HOLE	L	NH NUT HEX	JNH JAM NUT HEX	BH BODY HEX	PANEL HOLE
1-SBHU-1	1-1 WBZ	1/16	1.234	.344	.687	.437	.531	.052	.937	5/16	5/16	5/16	13/64
2-SBHU-2	2-2 WBZ	1/8	2.016	.500	1.234	.609	.969	.094	1.500	7/16	1/2	1/2	21/64
3-SBHU-3	3-3 WBZ	3/16	2.109	.547	1.266	.625	1.000	.125	1.594	1/2	9/16	9/16	25/64
4-SBHU-4	4-4 WBZ	1/4	2.266	.609	1.328	.703	1.031	.187	1.687	9/16	5/8	5/8	29/64
5-SBHU-5	5-5 WBZ	5/16	2.391	.641	1.406	.734	1.125	.250	1.812	5/8	11/16	11/16	33/64
6-SBHU-6	6-6 WBZ	3/8	2.453	.656	1.453	.766	1.156	.281	1.875	11/16	3/4	3/4	37/64
8-SBHU-8	8-8 WBZ	1/2	2.797	.906	1.656	.859	1.250	.406	2.000	7/8	15/16	15/16	49/64
10-SBHU-10	10-10 WBZ	5/8	2.859	.969	1.687	.859	1.281	.500	2.062	1	1-1/16	1-1/16	57/64
12-SBHU-12	12-12 WBZ	3/4	3.109	.969	1.875	.859	1.469	.625	2.312	1-1/8	1-3/16	1-3/16	1-1/64
14-SBHU-14	14-14 WBZ	7/8	3.328	1.031	2.094	.875	1.687	.718	2.531	1-1/4	1-3/8	1-3/8	1-9/64
16-SBHU-16	16-16 WBZ	1	3.766	1.234	2.266	1.047	1.781	.875	2.812	1-1/2	1-5/8	1-5/8	1-21/64

*NOTE: All dimensions subject to change, to be used for reference only.

Bulkhead to AN Flare Union

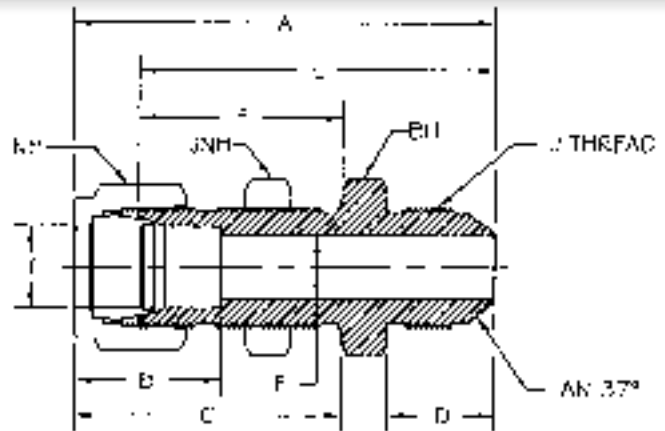
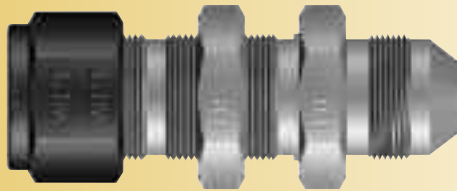

PART NUMBER	INTERCHANGES WITH	T TUBE O.D.	J THREAD	A	B	C	D	E ¹ THRU HOLE	F	L	NH NUT HEX	BH BODY HEX	JNH JAM NUT HEX	PANEL HOLE
2-SBUANF-2	2-2 XH2BZ	1/8	5/16-24	1.906	.500	1.234	.453	.062	.969	1.656	7/16	1/2	1/2	21/64
3-SBUANF-3	3-3 XH2BZ	3/16	3/8-24	1.984	.547	1.266	.484	.125	1.000	1.719	1/2	9/16	9/16	25/64
4-SBUANF-4	4-4 XH2BZ	1/4	7/16-20	2.125	.609	1.328	.547	.172	1.031	1.828	9/16	5/8	5/8	29/64
5-SBUANF-5	5-5 XH2BZ	5/16	1/2-20	2.219	.641	1.406	.547	.234	1.125	1.922	5/8	11/16	11/16	33/64
6-SBUANF-6	6-6 XH2BZ	3/8	9/16-18	2.250	.656	1.453	.562	.281	1.156	1.969	11/16	11/16	3/4	37/64
8-SBUANF-8	8-8 XH2BZ	1/2	3/4-16	2.594	.906	1.656	.656	.391	1.250	2.187	7/8	15/16	15/16	49/64
10-SBUANF-10	10-10 XH2BZ	5/8	7/8-14	2.734	.969	1.687	.766	.484	1.281	2.234	1	1-1/16	1-1/16	57/64
12-SBUANF-12	12-12 XH2BZ	3/4	1-1/16-12	3.109	.969	1.875	.859	.609	1.469	2.719	1-1/8	1-3/16	1-3/16	1-1/64
16-SBUANF-16	16-16 XH2BZ	1	1-5/16-12	3.641	1.234	2.266	.906	.844	1.781	3.156	1-1/2	1-5/8	1-5/8	1-21/64

*NOTE: All dimensions subject to change, to be used for reference only.

¹ The E dimension is the minimum opening. These fittings may have a larger opening at the pipe/straight thread end.

SCAP/SF Plug

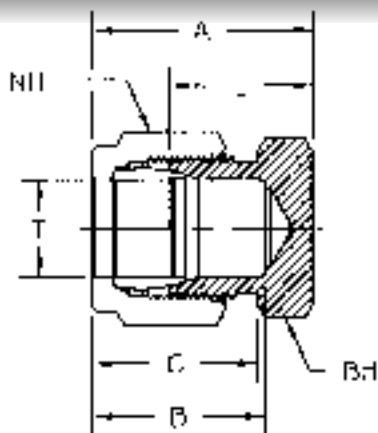

Cap



PART NUMBER	INTERCHANGES WITH	T TUBE O.D.	A	B	C	L	BH BODY HEX	NH NUT HEX
1-SCAP	1 PNBZ	1/16	.594	.344	.437	.437	5/16	5/16
2-SCAP	2 PNBZ	1/8	.797	.500	.609	.531	7/16	7/16
3-SCAP	3 PNBZ	3/16	.844	.547	.625	.578	7/16	1/2
4-SCAP	4 PNBZ	1/4	.922	.609	.703	.625	1/2	9/16
5-SCAP	5 PNBZ	5/16	.969	.641	.734	.672	9/16	5/8
6-SCAP	6 PNBZ	3/8	1.016	.656	.766	.719	5/8	11/16
8-SCAP	8 PNBZ	1/2	1.156	.906	.859	.750	13/16	7/8
10-SCAP	10 PNBZ	5/8	1.188	.969	.859	.781	15/16	1
12-SCAP	12 PNBZ	3/4	1.234	.969	.859	.844	1-1/16	1-1/8
14-SCAP	14 PNBZ	7/8	1.344	1.016	.859	.937	1-3/16	1-1/4
16-SCAP	16 PNBZ	1	1.516	1.234	1.047	1.031	1-3/8	1-1/2

*NOTE: All dimensions subject to change, to be used for reference only.

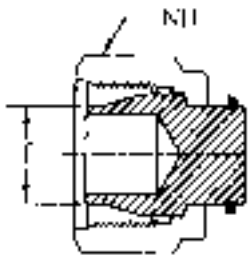

Fitting Plug



PART NUMBER	INTERCHANGES WITH	T TUBE O.D.	NH NUT HEX
1-SF PLUG	1 FNZ	1/16	5/16
2-SF PLUG	2 FNZ	1/8	7/16
3-SF PLUG	3 FNZ	3/16	1/2
4-SF PLUG	4 FNZ	1/4	9/16
5-SF PLUG	5 FNZ	5/16	5/8
6-SF PLUG	6 FNZ	3/8	11/16
8-SF PLUG	8 FNZ	1/2	7/8
10-SF PLUG	10 FNZ	5/8	1
12-SF PLUG	12 FNZ	3/4	1-1/8
14-SF PLUG	14 FNZ	7/8	1-1/4
16-SF PLUG	16 FNZ	1	1-1/2

*NOTE: All dimensions subject to change, to be used for reference only.

Female Connector

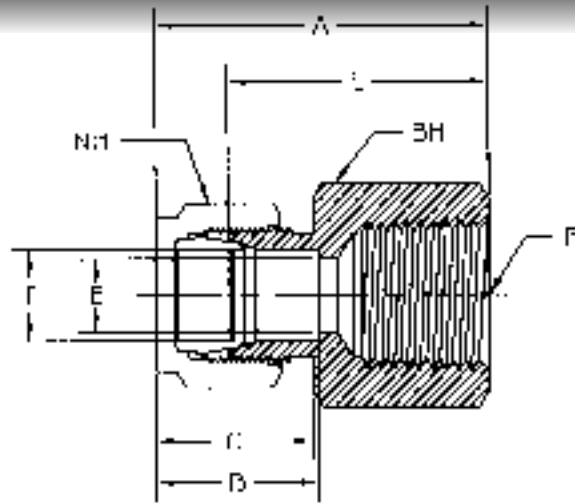

PART NUMBER	INTERCHANGES WITH	T TUBE O.D.	P PIPE END NPT	A	B	C	E THRU HOLE	L	NH NUT HEX	BH BODY HEX
1-SFC-1	1-1 GBZ	1/16	1/16	.937	.344	.437	.052	.782	5/16	7/16
1-SFC-2	1-2 GBZ	1/16	1/8	.969	.344	.437	.052	.812	5/16	9/16
2-SFC-2	2-2 GBZ	1/8	1/8	1.125	.500	.609	.094	.875	7/16	9/16
2-SFC-4	2-4 GBZ	1/8	1/4	1.328	.500	.609	.094	1.062	7/16	3/4
2-SFC-6	2-6 GBZ	1/8	3/8	1.390	.500	.609	.094	1.125	7/16	7/8
3-SFC-2	3-2 GBZ	3/16	1/8	1.171	.547	.625	.125	.906	1/2	9/16
3-SFC-4	3-4 GBZ	3/16	1/4	1.344	.547	.625	.125	1.094	1/2	3/4
3-SFC-8	3-8 GBZ	3/16	1/2	1.594	.547	.625	.125	1.344	1/2	1-1/16
4-SFC-1	4-1 GBZ	1/4	1/16	1.203	.609	.703	.187	.906	9/16	1/2
4-SFC-2	4-2 GBZ	1/4	1/8	1.234	.609	.703	.187	.937	9/16	9/16
4-SFC-4	4-4 GBZ	1/4	1/4	1.406	.609	.703	.187	1.125	9/16	3/4
4-SFC-6	4-6 GBZ	1/4	3/8	1.484	.609	.703	.187	1.187	9/16	7/8
4-SFC-8	4-8 GBZ	1/4	1/2	1.670	.609	.703	.187	1.375	9/16	1-1/16
5-SFC-2	5-2 GBZ	5/16	1/8	1.266	.640	.734	.250	.969	5/8	9/16
5-SFC-4	5-4 GBZ	5/16	1/4	1.453	.640	.734	.250	1.156	5/8	3/4
5-SFC-6	5-6 GBZ	5/16	3/8	1.515	.640	.734	.250	1.218	5/8	7/8
5-SFC-8	5-8 GBZ	5/16	1/2	1.703	.640	.734	.250	1.406	5/8	1-1/16
6-SFC-2	6-2 GBZ	3/8	1/8	1.297	.656	.766	.281	1.000	11/16	5/8
6-SFC-4	6-4 GBZ	3/8	1/4	1.484	.656	.766	.281	1.187	11/16	3/4
6-SFC-6	6-6 GBZ	3/8	3/8	1.547	.656	.766	.281	1.250	11/16	7/8
6-SFC-8	6-8 GBZ	3/8	1/2	1.734	.656	.766	.281	1.437	11/16	1-1/16
6-SFC-12	6-12 GBZ	3/8	3/4	1.875	.656	.766	.281	1.593	11/16	1-1/4
8-SFC-4	8-4 GBZ	1/2	1/4	1.593	.906	.859	.406	1.187	7/8	13/16
8-SFC-6	8-6 GBZ	1/2	3/8	1.656	.906	.859	.406	1.250	7/8	7/8
8-SFC-8	8-8 GBZ	1/2	1/2	1.843	.906	.859	.406	1.437	7/8	1-1/16
8-SFC-12	8-12 GBZ	1/2	3/4	1.906	.906	.859	.406	1.500	7/8	1-1/4
8-SFC-16	8-16 GBZ	1/2	1	2.265	.906	.859	.406	1.875	7/8	1-5/8
10-SFC-4	10-4 GBZ	5/8	1/4	1.797	.969	.859	.281	1.406	1	15/16
10-SFC-6	10-6 GBZ	5/8	3/8	1.656	.969	.859	.500	1.250	1	15/16
10-SFC-8	10-8 GBZ	5/8	1/2	1.844	.969	.859	.500	1.437	1	1-1/16
10-SFC-12	10-12 GBZ	5/8	3/4	1.953	.969	.859	.500	1.500	1	1-1/4
12-SFC-6	12-6 GBZ	3/4	3/8	1.655	.969	.859	.500	1.265	1-1/8	1-1/16
12-SFC-8	12-8 GBZ	3/4	1/2	1.844	.969	.859	.625	1.437	1-1/8	1-1/16
12-SFC-12	12-12 GBZ	3/4	3/4	1.906	.969	.859	.625	1.500	1-1/8	1-1/4
12-SFC-16	12-16 GBZ	3/4	1	2.265	.969	.859	.625	1.875	1-1/8	1-5/8
14-SFC-8	14-8 GBZ	7/8	1/2	1.828	1.016	.859	.687	1.437	1-1/4	1-3/16
14-SFC-12	14-12 GBZ	7/8	3/4	1.969	1.016	.859	.719	1.562	1-1/4	1-3/8
14-SFC-16	14-16 GBZ	7/8	1	2.234	1.016	.859	.719	1.843	1-1/4	1-5/8
16-SFC-12	16-12 GBZ	1	3/4	2.109	1.234	1.047	.875	1.625	1-1/2	1-3/8
16-SFC-16	16-16 GBZ	1	1	2.453	1.234	1.047	.875	1.969	1-1/2	1-5/8

*NOTE: All dimensions subject to change, to be used for reference only.

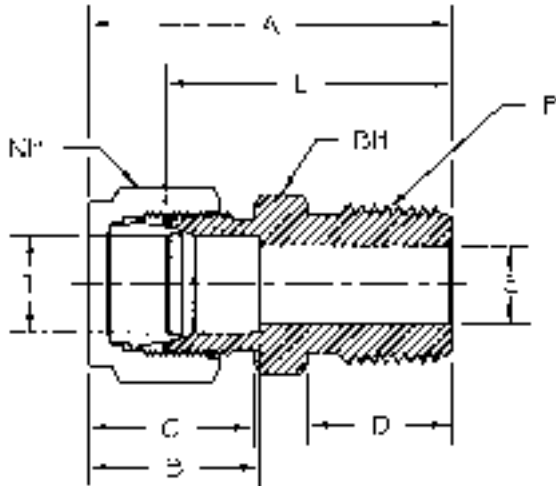

PART NUMBER	INTERCHANGES WITH	T TUBE O.D.	P PIPE END NPT	A	B	C	D	E ¹ THRU HOLE	L	NH NUT HEX	BH BODY HEX
1-SMC-1	1-1 FBZ	1/16	1/16	.937	.344	.437	.375	.052	.797	5/16	5/16
1-SMC-2	1-2 FBZ	1/16	1/8	1.031	.344	.437	.375	.052	.875	5/16	7/16
2-SMC-1	2-1 FBZ	1/8	1/16	1.172	.500	.609	.375	.094	.906	7/16	7/16
2-SMC-2	2-2 FBZ	1/8	1/8	1.203	.500	.609	.375	.094	.937	7/16	7/16
2-SMC-4	2-4 FBZ	1/8	1/4	1.406	.500	.609	.562	.094	1.140	7/16	9/16
2-SMC-6	2-6 FBZ	1/8	3/8	1.406	.500	.609	.562	.094	1.156	7/16	11/16
2-SMC-8	2-8 FBZ	1/8	1/2	1.656	.500	.609	.750	.094	1.406	7/16	7/8
3-SMC-2	3-2 FBZ	3/16	1/8	1.234	.546	.625	.375	.125	.969	1/2	7/16
3-SMC-4	3-4 FBZ	3/16	1/4	1.437	.546	.625	.562	.125	1.171	1/2	9/16
4-SMC-1	4-1 FBZ	1/4	1/16	1.299	.609	.703	.375	.125	1.000	9/16	1/2
4-SMC-2	4-2 FBZ	1/4	1/8	1.299	.609	.703	.375	.187	1.000	9/16	1/2
4-SMC-4	4-4 FBZ	1/4	1/4	1.484	.609	.703	.562	.187	1.203	9/16	9/16
4-SMC-6	4-6 FBZ	1/4	3/8	1.516	.609	.703	.562	.187	1.219	9/16	11/16
4-SMC-8	4-8 FBZ	1/4	1/2	1.766	.609	.703	.750	.187	1.469	9/16	7/8
4-SMC-12	4-12 FBZ	1/4	3/4	1.828	.609	.703	.750	.187	1.531	9/16	1-1/16
4-SMC-16	4-16 FBZ	1/4	1	2.109	.609	.703	.937	.187	1.812	9/16	1-3/8
5-SMC-2	5-2 FBZ	5/16	1/8	1.343	.641	.734	.375	.187	1.047	5/8	9/16
5-SMC-4	5-4 FBZ	5/16	1/4	1.516	.641	.734	.562	.250	1.234	5/8	9/16
5-SMC-6	5-6 FBZ	5/16	3/8	1.547	.641	.734	.562	.250	1.250	5/8	11/16
5-SMC-8	5-8 FBZ	5/16	1/2	1.765	.641	.734	.750	.250	1.468	5/8	7/8
6-SMC-2	6-2 FBZ	3/8	1/8	1.390	.656	.766	.375	.187	1.109	11/16	5/8
6-SMC-4	6-4 FBZ	3/8	1/4	1.578	.656	.766	.562	.281	1.281	11/16	5/8
6-SMC-6	6-6 FBZ	3/8	3/8	1.578	.656	.766	.562	.281	1.281	11/16	11/16
6-SMC-8	6-8 FBZ	3/8	1/2	1.828	.656	.766	.750	.281	1.531	11/16	7/8
6-SMC-12	6-12 FBZ	3/8	3/4	1.875	.656	.766	.750	.281	1.593	11/16	1-1/16
6-SMC-16	6-16 FBZ	3/8	1	2.141	.656	.766	.937	.281	1.843	11/16	1-3/8

*NOTE: All dimensions subject to change, to be used for reference only.

¹ The E dimension is the minimum opening. These fittings may have a larger opening at the pipe/straight thread end.

Male Connector

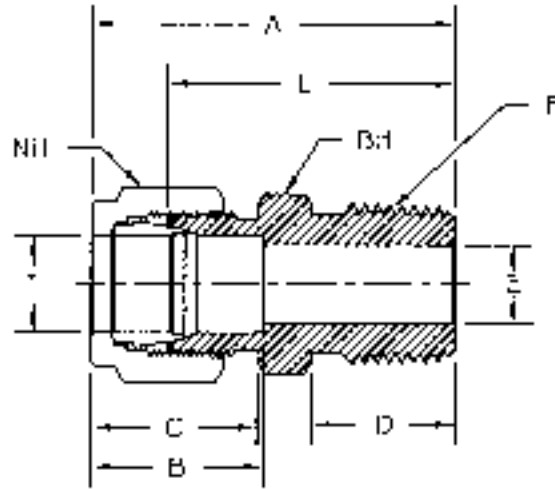

PART NUMBER	INTERCHANGES WITH	T TUBE O.D.	P PIPE END NPT	A	B	C	D	E ¹ THRU HOLE	L	NH NUT HEX	BH BODY HEX
8-SMC-2	8-2 FBZ	1/2	1/8	1.531	.906	.859	.375	.187	1.125	7/8	13/16
8-SMC-4	8-4 FBZ	1/2	1/4	1.719	.906	.859	.562	.281	1.312	7/8	13/16
8-SMC-6	8-6 FBZ	1/2	3/8	1.719	.906	.859	.562	.375	1.312	7/8	13/16
8-SMC-8	8-8 FBZ	1/2	1/2	1.937	.906	.859	.750	.406	1.531	7/8	7/8
8-SMC-12	8-12 FBZ	1/2	3/4	1.984	.906	.859	.750	.406	1.593	7/8	1-1/16
8-SMC-16	8-16 FBZ	1/2	1	2.250	.906	.859	.937	.406	1.859	7/8	1-3/8
10-SMC-4	10-4 FBZ	5/8	1/4	1.934	.969	.859	.562	.281	1.343	1	15/16
10-SMC-6	10-6 FBZ	5/8	3/8	1.934	.969	.859	.562	.375	1.343	1	15/16
10-SMC-8	10-8 FBZ	5/8	1/2	1.937	.969	.859	.750	.469	1.531	1	15/16
10-SMC-12	10-12 FBZ	5/8	3/4	1.984	.969	.859	.750	.500	1.593	1	1-1/16
10-SMC-16	10-16 FBZ	5/8	1	2.172	.969	.859	.937	.500	1.781	1	1-3/8
12-SMC-4	12-4 FBZ	3/4	1/4	1.796	.969	.859	.562	.281	1.405	1-1/8	1-1/16
12-SMC-6	12-6 FBZ	3/4	3/8	1.796	.969	.859	.562	.375	1.405	1-1/8	1-1/16
12-SMC-8	12-8 FBZ	3/4	1/2	1.984	.969	.859	.750	.468	1.593	1-1/8	1-1/16
12-SMC-12	12-12 FBZ	3/4	3/4	1.984	.969	.859	.750	.625	1.593	1-1/8	1-1/16
12-SMC-16	12-16 FBZ	3/4	1	2.250	.969	.859	.937	.625	1.859	1-1/8	1-3/8
14-SMC-8	14-8 FBZ	7/8	1/2	1.984	1.015	.859	.750	.468	1.593	1-1/4	1-3/16
14-SMC-12	14-12 FBZ	7/8	3/4	1.984	1.015	.859	.750	.625	1.593	1-1/4	1-3/16
14-SMC-16	14-16 FBZ	7/8	1	2.250	1.015	.859	.937	.718	1.859	1-1/4	1-3/8
16-SMC-4	16-4 FBZ	1	1/4	2.055	1.234	1.046	.562	.281	1.562	1-1/2	1-3/8
16-SMC-6	16-6 FBZ	1	3/8	2.055	1.234	1.046	.562	.375	1.562	1-1/2	1-3/8
16-SMC-8	16-8 FBZ	1	1/2	2.265	1.234	1.046	.750	.468	1.781	1-1/2	1-3/8
16-SMC-12	16-12 FBZ	1	3/4	2.265	1.234	1.046	.750	.625	1.781	1-1/2	1-3/8
16-SMC-16	16-16 FBZ	1	1	2.453	1.234	1.046	.937	.875	1.969	1-1/2	1-3/8

*NOTE: All dimensions subject to change, to be used for reference only.

¹ The E dimension is the minimum opening. These fittings may have a larger opening at the pipe/straight thread end.

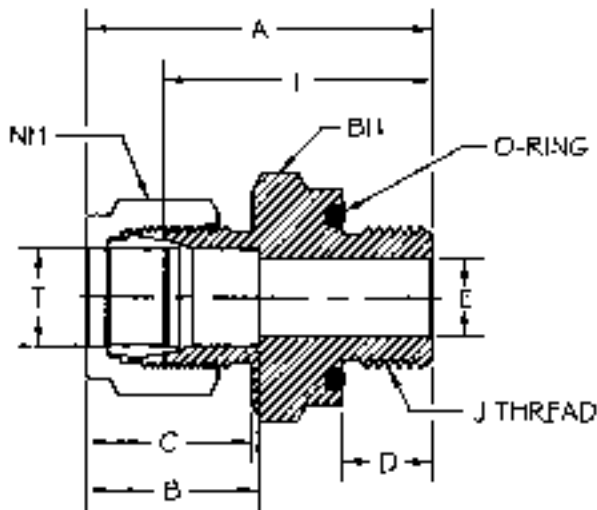

O-Ring Straight Thread Male Connector

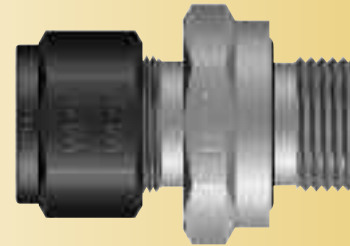

PART NUMBER	INTERCHANGES WITH	T TUBE O.D.	J THREAD	A	B	C	D	E ¹ THRU HOLE	L	NH NUT HEX	BH BODY HEX	O-RING
1-SMC-ORS	1-1 ZHBA5	1/16	5/16-24	1.047	.344	.437	.343	.052	.906	5/16	9/16	AS-011
2-SMC-ORS	2-2 ZHBA5	1/8	5/16-24	1.297	.500	.609	.343	.094	1.031	7/16	9/16	AS-011
3-SMC-ORS	3-3 ZHBA5	3/16	3/8-24	1.359	.547	.625	.375	.125	1.094	1/2	5/8	AS-012
4-SMC-ORS	4-4 ZHBA5	1/4	7/16-20	1.516	.609	.703	.406	.187	1.219	9/16	3/4	AS-111
5-SMC-ORS	5-5 ZHBA5	5/16	1/2-20	1.609	.641	.734	.437	.250	1.312	5/8	7/8	AS-112
6-SMC-ORS	6-6 ZHBA5	3/8	9/16-18	1.672	.656	.766	.468	.281	1.375	11/16	15/16	AS-113
8-SMC-ORS	8-8 ZHBA5	1/2	3/4-16	1.812	.906	.859	.468	.406	1.406	7/8	1-1/8	AS-116
12-SMC-ORS	12-12 ZHBA5	3/4	1-1/16-12	2.062	.969	.859	.562	.625	1.656	1-1/8	1-1/2	AS-215
16-SMC-ORS	16-16 ZHBA5	1	1-5/16-12	2.297	1.234	1.047	.562	.875	1.812	1-1/2	1-3/4	AS-219

*NOTE: All dimensions subject to change, to be used for reference only.

¹ The E dimension is the minimum opening. These fittings may have a larger opening at the pipe/straight thread end.

O-Ring Pipe Thread Male Connector

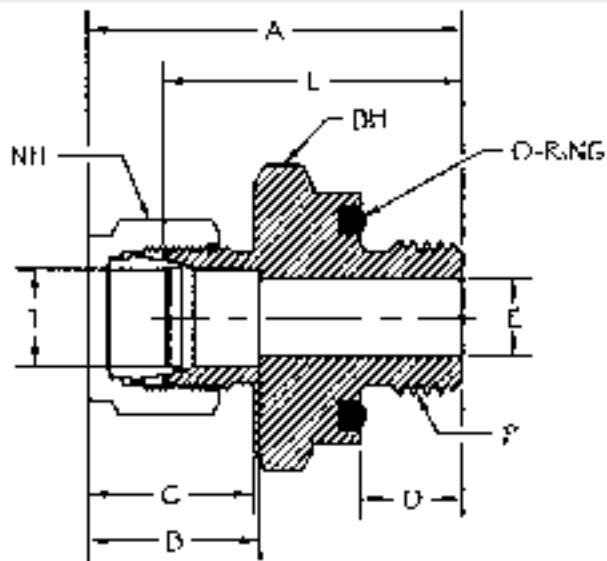
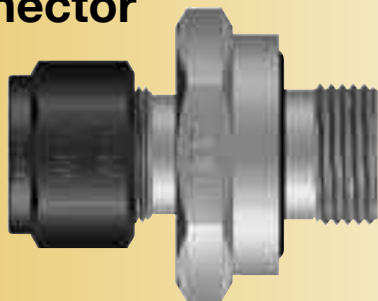

PART NUMBER	INTERCHANGES WITH	T TUBE O.D.	P PIPE END NPT	A	B	C	D	E ¹ THRU HOLE	L	NH NUT HEX	BH BODY HEX	O-RING
2-SMC-2-ORT	2-2 ZHBF5	1/8	1/8	1.297	.500	.609	.280	.094	1.031	7/16	3/4	AS-111
2-SMC-4-ORT	2-4 ZHBF5	1/8	1/4	1.437	.516	.609	.375	.094	1.172	7/16	15/16	AS-113
3-SMC-4-ORT	3-4 ZHBF5	3/16	1/4	1.469	.547	.641	.375	.125	1.203	1/2	15/16	AS-113
4-SMC-2-ORT	4-2 ZHBF5	1/4	1/8	1.375	.609	.703	.280	.187	1.094	9/16	3/4	AS-111
4-SMC-4-ORT	4-4 ZHBF5	1/4	1/4	1.516	.609	.703	.375	.187	1.219	9/16	15/16	AS-113
6-SMC-6-ORT	6-6 ZHBF5	3/8	3/8	1.625	.656	.766	.406	.281	1.344	11/16	1-1/8	AS-116
6-SMC-8-ORT	6-8 ZHBF5	3/8	1/2	1.859	.656	.766	.531	.281	1.562	11/16	1-3/8	AS-212
8-SMC-4-ORT	8-4 ZHBF5	1/2	1/4	1.687	.906	.875	.375	.281	1.281	7/8	15/16	AS-113
8-SMC-8-ORT	8-8 ZHBF5	1/2	1/2	1.969	.906	.859	.531	.406	1.562	7/8	1-3/8	AS-212
10-SMC-12-ORT	10-12 ZHBF5	5/8	3/4	2.062	.969	.875	.562	.500	1.656	1	1-1/2	AS-215
12-SMC-12-ORT	12-12 ZHBF5	3/4	3/4	2.062	.969	.875	.562	.625	1.656	1-1/8	1-1/2	AS-215

*NOTE: All dimensions subject to change, to be used for reference only.

**NOTE: Stainless steel and carbon steel o-seal fittings up to 1 inch are rated to 3000 psi.

¹ The E dimension is the minimum opening. These fittings may have a larger opening at the pipe/straight thread end.

Port Connector Union

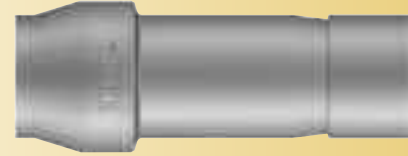
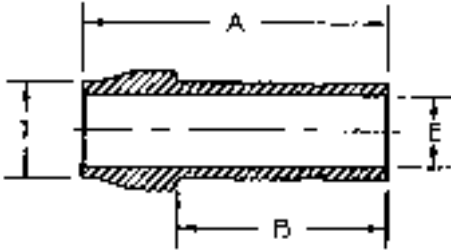

PART NUMBER	INTERCHANGES WITH	T TUBE O.D.	A	B	E THRU HOLE
1-SPCU	1-1 ZPC	1/16	.687	.437	.031
2-SPCU	2-2 ZPC	1/8	.969	.656	.078
4-SPCU	4-4 ZPC	1/4	1.078	.765	.156
5-SPCU	5-5 ZPC	5/16	1.125	.812	.219
6-SPCU	6-6 ZPC	3/8	1.156	.843	.281
8-SPCU	8-8 ZPC	1/2	1.594	1.109	.375
12-SPCU	12-12 ZPC	3/4	1.656	1.156	.578
16-SPCU	16-16 ZPC	1	2.125	1.437	.812

*NOTE: All dimensions subject to change, to be used for reference only.

**NOTE: Stainless steel and carbon steel o-seal fittings up to 1 inch are rated to 3000 psi.

Reducer Adapter Tube to Tube

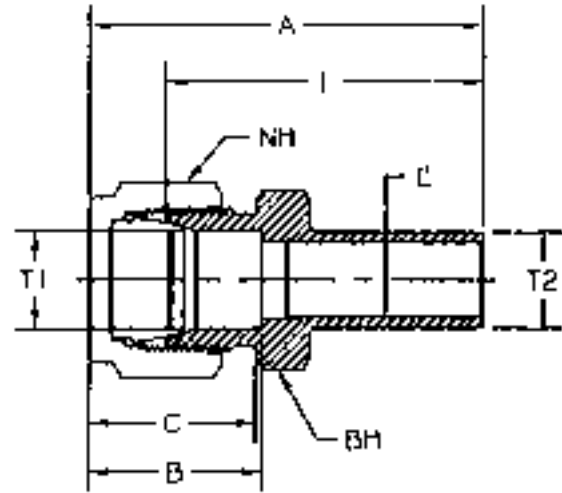

PART NUMBER	INTERCHANGES WITH	T1 TUBE O.D.	T2 TUBE O.D.	A	B	C	E THRU HOLE	L	NH NUT HEX	BH BODY HEX
1-SRATT-2	2-1 TRBZ	1/16	1/8	1.187	.344	.437	.052	1.031	5/16	5/16
1-SRATT-4	4-1 TRBZ	1/16	1/4	1.281	.344	.437	.052	1.125	5/16	5/16
2-SRATT-1	1-2 TRBZ	1/8	1/16	1.250	.500	.609	.031	.984	7/16	7/16
2-SRATT-2	2-2 TRBZ	1/8	1/8	1.375	.500	.609	.078	1.109	7/16	7/16
2-SRATT-3	3-2 TRBZ	1/8	3/16	1.422	.500	.609	.094	1.156	7/16	7/16
2-SRATT-4	4-2 TRBZ	1/8	1/4	1.453	.500	.609	.094	1.187	7/16	7/16
2-SRATT-6	6-2 TRBZ	1/8	3/8	1.562	.500	.609	.094	1.296	7/16	7/16
2-SRATT-8	8-2 TRBZ	1/8	1/2	1.828	.500	.609	.094	1.562	7/16	9/16
3-SRATT-2	2-3 TRBZ	3/16	1/8	1.406	.547	.625	.078	1.141	1/2	7/16
3-SRATT-4	4-3 TRBZ	3/16	1/4	1.484	.547	.625	.125	1.218	1/2	7/16
4-SRATT-2	2-4 TRBZ	1/4	1/8	1.484	.609	.703	.078	1.187	9/16	1/2
4-SRATT-4	4-4 TRBZ	1/4	1/4	1.562	.609	.703	.156	1.265	9/16	1/2
4-SRATT-5	5-4 TRBZ	1/4	5/16	1.609	.609	.703	.187	1.312	9/16	1/2
4-SRATT-6	6-4 TRBZ	1/4	3/8	1.656	.609	.703	.187	1.359	9/16	1/2
4-SRATT-8	8-4 TRBZ	1/4	1/2	1.922	.609	.703	.187	1.625	9/16	9/16
4-SRATT-10	10-4 TRBZ	1/4	5/8	2.000	.609	.703	.187	1.703	9/16	11/16
5-SRATT-6	6-5 TRBZ	5/16	3/8	1.687	.641	.734	.250	1.390	5/8	9/16
5-SRATT-8	8-5 TRBZ	5/16	1/2	1.953	.641	.734	.250	1.656	5/8	9/16
6-SRATT-6	6-6 TRBZ	3/8	3/8	1.734	.656	.766	.281	1.437	11/16	5/8
6-SRATT-10	10-6 TRBZ	3/8	5/8	2.062	.656	.766	.281	1.765	11/16	11/16
6-SRATT-12	12-6 TRBZ	3/8	3/4	2.078	.656	.766	.281	1.781	11/16	13/16
8-SRATT-4	4-8 TRBZ	1/2	1/4	1.796	.906	.859	.156	1.390	7/8	13/16
8-SRATT-6	6-8 TRBZ	1/2	3/8	1.890	.906	.859	.281	1.484	7/8	13/16
8-SRATT-8	8-8 TRBZ	1/2	1/2	2.140	.906	.859	.375	1.734	7/8	13/16
8-SRATT-10	10-8 TRBZ	1/2	5/8	2.187	.906	.859	.406	1.781	7/8	13/16
8-SRATT-12	12-8 TRBZ	1/2	3/4	2.187	.906	.859	.406	1.781	7/8	13/16
8-SRATT-16	16-8 TRBZ	1/2	1	2.546	.906	.859	.406	2.140	7/8	1-1/16
10-SRATT-12	12-10 TRBZ	5/8	3/4	2.218	.969	.859	.500	1.812	1	15/16
10-SRATT-14	14-10 TRBZ	5/8	7/8	2.265	.969	.859	.500	1.859	1	15/16
10-SRATT-16	16-10 TRBZ	5/8	1	2.484	.969	.859	.500	2.078	1	1-1/16
12-SRATT-8	8-12 TRBZ	3/4	1/2	2.234	.969	.859	.375	1.828	1-1/8	1-1/16
12-SRATT-16	16-12 TRBZ	3/4	1	2.546	.969	.859	.625	2.140	1-1/8	1-1/16

*NOTE: All dimensions subject to change, to be used for reference only.

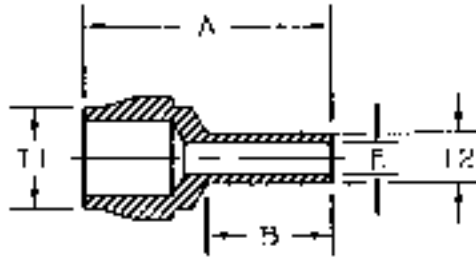

Reducing Port Connector

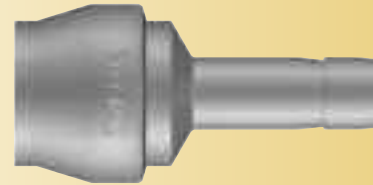

PART NUMBER	INTERCHANGES WITH	T1 TUBE O.D.	T2 TUBE O.D.	A	B	E THRU HOLE
2-SRPC-1	1-2 ZPC	1/8	1/16	.906	.437	.031
4-SRPC-1	1-4 ZPC	1/4	1/16	.968	.437	.031
4-SRPC-2	2-4 ZPC	1/4	1/8	1.078	.562	.078
6-SRPC-2	2-6 ZPC	3/8	1/8	1.109	.562	.078
6-SRPC-4	4-6 ZPC	3/8	1/4	1.156	.640	.156
8-SRPC-4	4-8 ZPC	1/2	1/4	1.359	.640	.156
8-SRPC-6	6-8 ZPC	1/2	3/8	1.406	.718	.281
12-SRPC-8	8-12 ZPC	3/4	1/2	1.718	.984	.375

*NOTE: All dimensions subject to change, to be used for reference only.

Reducing Union

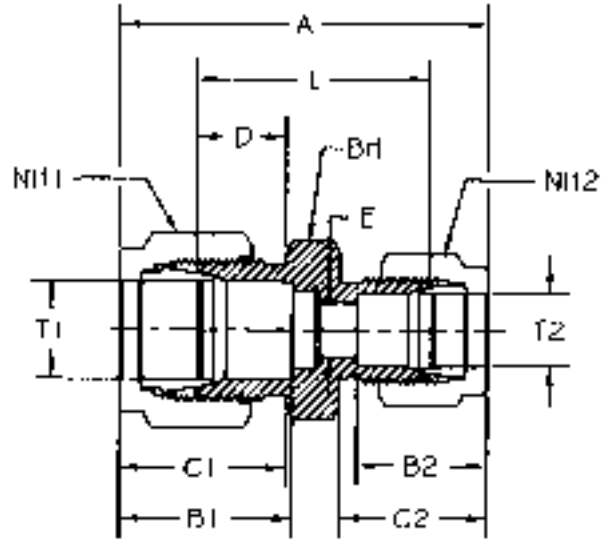

PART NUMBER	INTERCHANGES WITH	T1 TUBE O.D.	T2 TUBE O.D.	A	B1	B2	C1	C2	D	E THRU HOLE	L	NH1 NUT HEX	NH2 NUT HEX	BH BODY HEX
2-SRU-1	2-1 HBZ	1/8	1/16	1.219	.500	.344	.609	.437	.343	.052	.812	7/16	5/16	7/16
3-SRU-1	3-1 HBZ	3/16	1/16	1.266	.547	.344	.625	.437	.375	.052	.859	1/2	5/16	7/16
3-SRU-2	3-2 HBZ	3/16	1/8	1.437	.547	.500	.625	.609	.375	.094	.922	1/2	7/16	7/16
4-SRU-2	4-2 HBZ	1/4	1/8	1.516	.609	.500	.703	.609	.406	.094	.969	9/16	7/16	1/2
4-SRU-3	4-3 HBZ	1/4	3/16	1.547	.609	.547	.703	.625	.406	.125	1.000	9/16	1/2	1/2
5-SRU-2	5-2 HBZ	5/16	1/8	1.578	.641	.500	.734	.609	.437	.094	1.016	5/8	7/16	9/16
5-SRU-4	5-4 HBZ	5/16	1/4	1.656	.641	.609	.734	.703	.437	.187	1.078	5/8	9/16	9/16
6-SRU-1	6-1 HBZ	3/8	1/16	1.437	.656	.344	.765	.437	.468	.052	1.000	11/16	5/16	5/8
6-SRU-2	6-2 HBZ	3/8	1/8	1.609	.656	.500	.765	.609	.468	.094	1.062	11/16	7/16	5/8
6-SRU-4	6-4 HBZ	3/8	1/4	1.703	.656	.609	.765	.703	.468	.187	1.125	11/16	9/16	5/8
6-SRU-5	6-5 HBZ	3/8	5/16	1.734	.656	.641	.765	.734	.468	.250	1.156	11/16	5/8	5/8
8-SRU-2	8-2 HBZ	1/2	1/8	1.781	.906	.500	.859	.609	.468	.094	1.125	7/8	7/16	13/16
8-SRU-4	8-4 HBZ	1/2	1/4	1.859	.906	.609	.859	.703	.468	.187	1.156	7/8	9/16	13/16
8-SRU-6	8-6 HBZ	1/2	3/8	1.906	.906	.656	.859	.765	.468	.281	1.219	7/8	11/16	13/16
10-SRU-6	10-6 HBZ	5/8	3/8	1.937	.969	.656	.859	.765	.468	.281	1.250	1	11/16	15/16
10-SRU-8	10-8 HBZ	5/8	1/2	2.047	.969	.906	.859	.859	.468	.406	1.250	1	7/8	15/16
12-SRU-4	12-4 HBZ	3/4	1/4	1.937	.969	.609	.859	.703	.468	.187	1.250	1-1/8	9/16	1-1/16
12-SRU-6	12-6 HBZ	3/4	3/8	2.000	.969	.656	.859	.765	.468	.281	1.312	1-1/8	11/16	1-1/16
12-SRU-8	12-8 HBZ	3/4	1/2	2.109	.969	.906	.859	.859	.468	.406	1.312	1-1/8	7/8	1-1/16
12-SRU-10	12-10 HBZ	3/4	5/8	2.109	.969	.969	.859	.859	.468	.500	1.312	1-1/8	1	1-1/16
16-SRU-12	16-12 HBZ	1	3/4	2.469	1.234	.969	1.047	.859	.562	.625	1.594	1-1/2	1-1/8	1-3/8

*NOTE: All dimensions subject to change, to be used for reference only.

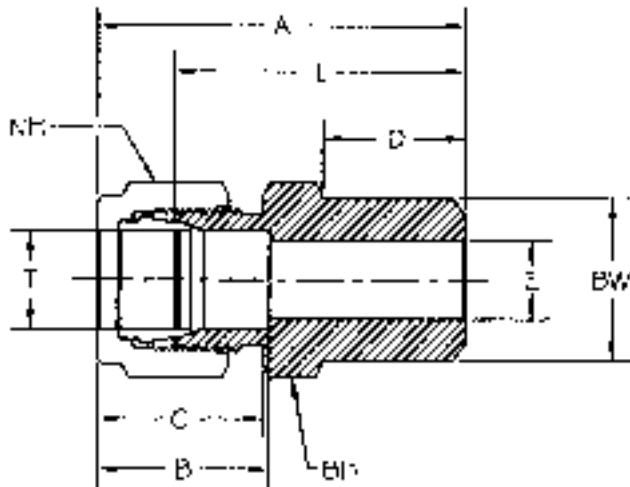

PART NUMBER	INTERCHANGES WITH	T TUBE O.D.	BW	A	B	C	D	E ¹ THRU HOLE	L	NH NUT HEX	BH BODY HEX
2-STBW-2	2-1/8 ZHBW2	1/8	.405	1.203	.500	.609	.375	.094	.937	7/16	7/16
3-STBW-2	3-1/8 ZHBW2	3/16	.405	1.234	.547	.625	.375	.125	.969	1/2	7/16
4-STBW-2	4-1/8 ZHBW2	1/4	.405	1.297	.609	.703	.375	.187	1.000	9/16	1/2
4-STBW-4	4-1/4 ZHBW2	1/4	.540	1.484	.609	.703	.562	.187	1.203	9/16	9/16
5-STBW-4	5-1/4 ZHBW2	5/16	.540	1.516	.641	.734	.562	.250	1.234	5/8	9/16
6-STBW-4	6-1/4 ZHBW2	3/8	.540	1.578	.656	.766	.562	.281	1.281	11/16	5/8
6-STBW-6	6-3/8 ZHBW2	3/8	.675	1.578	.656	.766	.562	.281	1.281	11/16	3/4
6-STBW-8	6-1/2 ZHBW2	3/8	.840	1.828	.656	.766	.750	.281	1.531	11/16	7/8
8-STBW-6	8-3/8 ZHBW2	1/2	.675	1.719	.906	.859	.562	.406	1.312	7/8	13/16
8-STBW-8	8-1/2 ZHBW2	1/2	.840	1.937	.906	.859	.750	.406	1.531	7/8	7/8
8-STBW-12	8-3/4 ZHBW2	1/2	1.050	1.984	.906	.859	.750	.406	1.594	7/8	1-1/16
10-STBW-8	10-1/2 ZHBW2	5/8	.840	1.937	.969	.859	.750	.500	1.531	1	15/16
12-STBW-12	12-3/4 ZHBW2	3/4	1.050	1.984	.969	.859	.750	.625	1.594	1-1/8	1-1/16
16-STBW-16	16-1 ZHBW2	1	1.315	2.453	1.234	1.047	.937	.875	1.969	1-1/2	1-3/8

*NOTE: All dimensions subject to change, to be used for reference only.

¹ The E dimension is the minimum opening. These fittings may have a larger opening at the pipe/straight thread end.

Tube to Socket Weld Connector

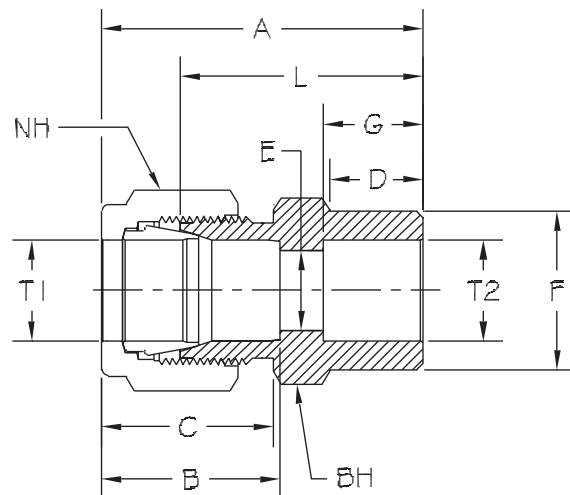

PART NUMBER	INTERCHANGES WITH	T1 TUBE O.D.	T2 TUBE O.D.	A	B	C	D	E THRU HOLE	F	G	L	NH NUT HEX	BH BODY HEX
2-STSW-2	2-2 ZHBW	1/8	1/8	1.141	.500	.609	.344	.094	.312	.250	.875	7/16	7/16
3-STSW-3	3-3 ZHBW	3/16	3/16	1.203	.547	.641	.375	.125	.406	.281	.937	1/2	7/16
4-STSW-4	4-4 ZHBW	1/4	1/4	1.328	.609	.703	.406	.187	.437	.312	1.031	9/16	1/2
6-STSW-6	6-6 ZHBW	3/8	3/8	1.484	.656	.766	.469	.281	.625	.375	1.187	11/16	5/8
8-STSW-8	8-8 ZHBW	1/2	1/2	1.625	.906	.859	.469	.406	.750	.500	1.219	7/8	13/16
10-STSW-10	10-10 ZHBW	5/8	5/8	1.656	.969	.859	.469	.500	.922	.500	1.250	1	15/16
12-STSW-12	12-12 ZHBW	3/4	3/4	1.719	.969	.859	.469	.625	1.047	.562	1.312	1-1/8	1-1/16
16-STSW-16	16-16 ZHBW	1	1	2.078	1.234	1.047	.562	.875	1.312	.750	1.594	1-1/2	1-3/8

*NOTE: All dimensions subject to change, to be used for reference only.

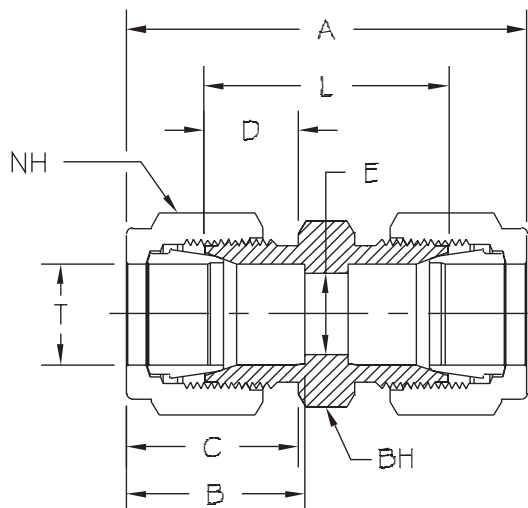

PART NUMBER	INTERCHANGES WITH	T TUBE O.D.	A	B	C	D	E THRU HOLE	L	NH NUT HEX	BH BODY HEX
1-SU	1-1 HBZ	1/16	.984	.344	.437	.281	.052	.687	5/16	5/16
2-SU	2-2 HBZ	1/8	1.406	.500	.609	.343	.094	.875	7/16	7/16
3-SU	3-3 HBZ	3/16	1.469	.547	.625	.375	.125	.953	1/2	7/16
4-SU	4-4 HBZ	1/4	1.609	.609	.703	.406	.187	1.031	9/16	1/2
5-SU	5-5 HBZ	5/16	1.687	.641	.734	.437	.250	1.109	5/8	9/16
6-SU	6-6 HBZ	3/8	1.766	.656	.766	.468	.281	1.187	11/16	5/8
8-SU	8-8 HBZ	1/2	2.016	.906	.859	.468	.406	1.219	7/8	13/16
10-SU	10-10 HBZ	5/8	2.047	.969	.859	.468	.500	1.250	1	15/16
12-SU	12-12 HBZ	3/4	2.109	.969	.859	.468	.625	1.312	1-1/8	1-1/16
14-SU	14-14 HBZ	7/8	2.187	1.016	.859	.468	.718	1.375	1-1/4	1-3/16
16-SU	16-16 HBZ	1	2.547	1.234	1.047	.562	.875	1.594	1-1/2	1-3/8

*NOTE: All dimensions subject to change, to be used for reference only.

Tube to AN Flare Union

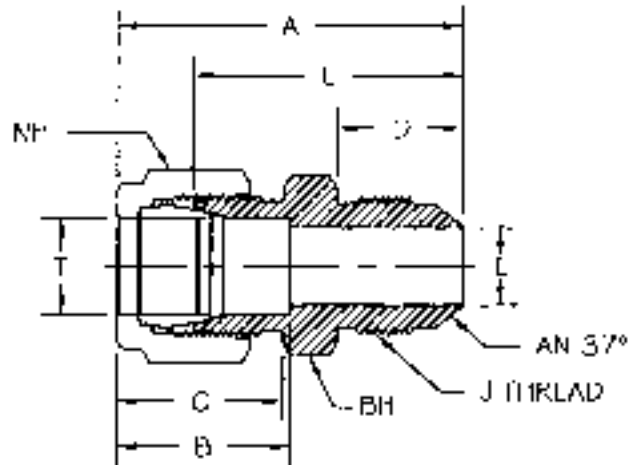
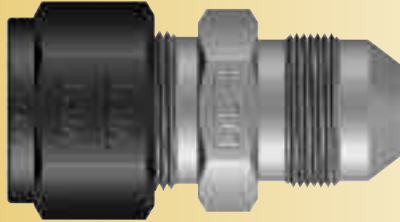

PART NUMBER	INTERCHANGES WITH	T TUBE O.D.	J THREAD	A	B	C	D	E ¹ THRU HOLE	L	NH NUT HEX	BH BODY HEX
2-SUANF-2	2-2 XHBZ	1/8	5/16-24	1.234	.500	.609	.448	.062	.984	7/16	7/16
2-SUANF-4	4-2 XHBZ	1/8	7/16-20	1.375	.500	.609	.550	.094	1.125	7/16	1/2
3-SUANF-3	3-3 XHBZ	3/16	3/8-24	1.328	.547	.641	.479	.125	1.062	1/2	7/16
4-SUANF-4	4-4 XHBZ	1/4	7/16-20	1.484	.609	.703	.550	.172	1.187	9/16	1/2
5-SUANF-5	5-5 XHBZ	5/16	1/2-20	1.516	.641	.734	.550	.234	1.219	5/8	9/16
6-SUANF-4	4-6 XHBZ	3/8	7/16-20	1.562	.656	.766	.550	.172	1.266	11/16	5/8
6-SUANF-6	6-6 XHBZ	3/8	9/16-18	1.562	.656	.766	.556	.297	1.266	11/16	5/8
8-SUANF-8	8-8 XHBZ	1/2	3/4-16	1.812	.906	.859	.657	.391	1.406	7/8	13/16
10-SUANF-10	10-10 XHBZ	5/8	7/8-14	1.937	.969	.875	.758	.484	1.531	1	15/16
12-SUANF-12	12-12 XHBZ	3/4	1-1/16-12	2.109	.969	.859	.864	.609	1.703	1-1/8	1-1/8
16-SUANF-16	16-16 XHBZ	1	1-5/16-12	2.422	1.234	1.047	.911	.844	1.937	1-1/2	1-3/8

*NOTE: All dimensions subject to change, to be used for reference only.

¹ The E dimension is the minimum opening. These fittings may have a larger opening at the pipe/straight thread end.

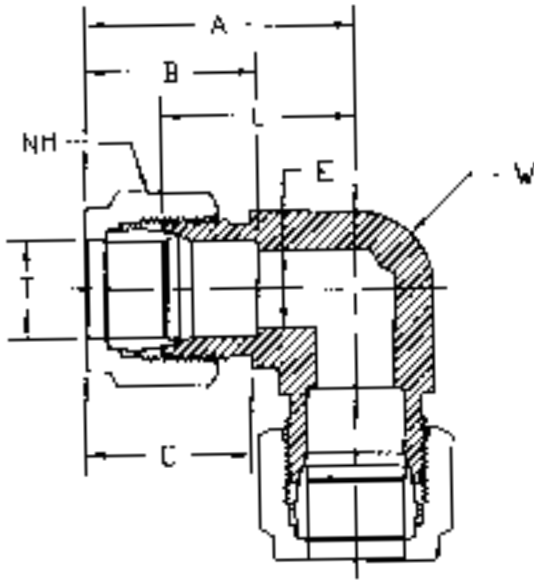

Union Elbow

PART NUMBER	INTERCHANGES WITH	T TUBE O.D.	A	B	C	E THRU HOLE	L	NH NUT HEX	W WRENCH FLAT
1-SELU-1	1-1 EBZ	1/16	.750	.344	.437	.052	.609	5/16	7/16
2-SELU-2	2-2 EBZ	1/8	.875	.500	.609	.094	.625	7/16	3/8
3-SELU-3	3-3 EBZ	3/16	1.000	.547	.625	.125	.734	1/2	1/2
4-SELU-4	4-4 EBZ	1/4	1.062	.609	.703	.187	.766	9/16	1/2
5-SELU-5	5-5 EBZ	5/16	1.125	.640	.734	.250	.844	5/8	5/8
6-SELU-6	6-6 EBZ	3/8	1.203	.656	.766	.281	.906	11/16	5/8
8-SELU-8	8-8 EBZ	1/2	1.421	.906	.859	.406	1.016	7/8	13/16
10-SELU-10	10-10 EBZ	5/8	1.500	.969	.859	.500	1.109	1	15/16
12-SELU-12	12-12 EBZ	3/4	1.578	.969	.859	.625	1.171	1-1/8	1-1/16
14-SELU-14	14-14 EBZ	7/8	1.766	1.016	.859	.718	1.359	1-1/4	1-3/8
16-SELU-16	16-16 EBZ	1	1.937	1.234	1.047	.875	1.453	1-1/2	1-3/8

*NOTE: All dimensions subject to change, to be used for reference only.

Female Elbow

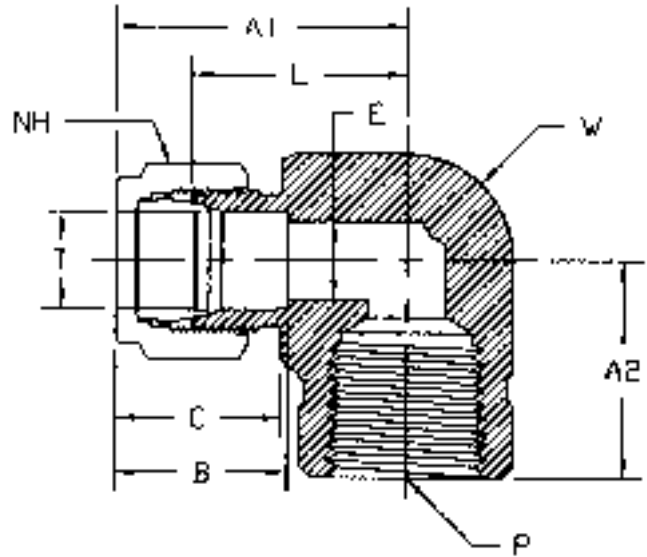

PART NUMBER	INTERCHANGES WITH	T TUBE O.D.	P PIPE END NPT	A1	A2	B	C	E THRU HOLE	L	NH NUT HEX	W WRENCH FLAT
1-SFE-2	1-2 DBZ	1/16	1/8	.812	.750	.500	.609	.052	.687	5/16	1/2
2-SFE-2	2-2 DBZ	1/8	1/8	.969	.750	.500	.609	.094	.719	7/16	1/2
2-SFE-4	2-4 DBZ	1/8	1/4	1.078	.875	.500	.609	.094	.828	7/16	11/16
3-SFE-2	3-2 DBZ	3/16	1/8	1.000	.750	.547	.625	.125	.734	1/2	1/2
4-SFE-2	4-2 DBZ	1/4	1/8	1.062	.750	.609	.703	.187	.781	9/16	1/2
4-SFE-4	4-4 DBZ	1/4	1/4	1.172	.875	.609	.703	.187	.875	9/16	11/16
4-SFE-6	4-6 DBZ	1/4	3/8	1.250	.875	.609	.703	.187	.969	9/16	13/16
4-SFE-8	4-8 DBZ	1/4	1/2	1.359	1.125	.609	.703	.187	1.078	9/16	1
5-SFE-2	5-2 DBZ	5/16	1/8	1.125	.750	.640	.734	.250	.844	5/8	9/16
5-SFE-4	5-4 DBZ	5/16	1/4	1.203	.875	.640	.734	.250	.906	5/8	11/16
6-SFE-2	6-2 DBZ	3/8	1/8	1.203	.750	.656	.766	.281	.906	11/16	5/8
6-SFE-4	6-4 DBZ	3/8	1/4	1.234	.875	.656	.766	.281	.937	11/16	11/16
6-SFE-6	6-6 DBZ	3/8	3/8	1.312	.875	.656	.766	.281	1.016	11/16	13/16
6-SFE-8	6-8 DBZ	3/8	1/2	1.429	1.125	.656	.766	.281	1.125	11/16	1-1/16
8-SFE-4	8-4 DBZ	1/2	1/4	1.429	.875	.906	.859	.406	1.016	7/8	13/16
8-SFE-6	8-6 DBZ	1/2	3/8	1.429	.875	.906	.859	.406	1.016	7/8	13/16
8-SFE-8	8-8 DBZ	1/2	1/2	1.531	1.125	.906	.859	.406	1.125	7/8	1-1/16
10-SFE-6	10-6 DBZ	5/8	3/8	1.500	.875	.969	.859	.500	1.109	1	15/16
10-SFE-8	10-8 DBZ	5/8	1/2	1.578	1.125	.969	.859	.500	1.171	1	1-1/16
12-SFE-8	12-8 DBZ	3/4	1/2	1.578	1.125	.969	.859	.625	1.171	1-1/8	1-1/16
12-SFE-12	12-12 DBZ	3/4	3/4	1.766	1.250	.969	.859	.625	1.359	1-1/8	1-3/8
14-SFE-12	14-12 DBZ	7/8	3/4	1.766	1.250	1.016	.859	.718	1.359	1-1/4	1-3/8
16-SFE-12	16-12 DBZ	1	3/4	1.937	1.250	1.234	1.049	.875	1.453	1-1/2	1-3/8
16-SFE-16	16-16 DBZ	1	1	1.984	1.500	1.234	1.049	.875	1.500	1-1/2	1-11/16

*NOTE: All dimensions subject to change, to be used for reference only.

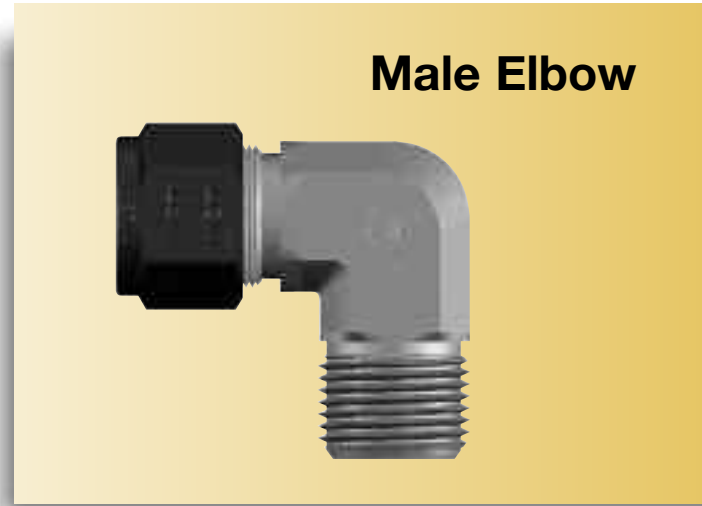
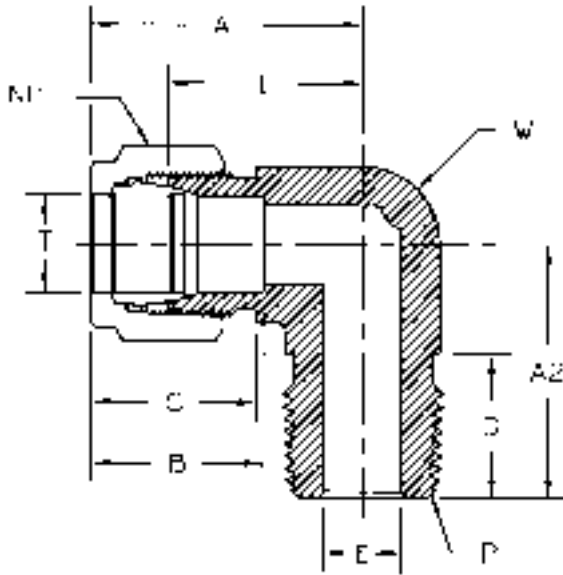

PART NUMBER	INTERCHANGES WITH	T TUBE O.D.	P PIPE END NPT	A1	A2	B	C	D	E ¹ THRU HOLE	L	NH NUT HEX	W WRENCH FLAT
1-SME-1	1-1 CBZ	1/16	1/16	.703	.703	.344	.437	.375	.052	.609	5/16	3/8
1-SME-2	1-2 CBZ	1/16	1/8	.750	.703	.344	.437	.375	.052	.609	5/16	7/16
2-SME-1	2-1 CBZ	1/8	1/16	.937	.703	.500	.609	.375	.094	.672	7/16	7/16
2-SME-2	2-2 CBZ	1/8	1/8	.937	.703	.500	.609	.375	.094	.672	7/16	7/16
2-SME-4	2-4 CBZ	1/8	1/4	.969	.922	.500	.609	.562	.094	.719	7/16	1/2
2-SME-6	2-6 CBZ	1/8	3/8	1.203	1.125	.500	.609	.562	.094	.812	7/16	13/16
3-SME-2	3-2 CBZ	3/16	1/8	1.000	.734	.547	.625	.375	.125	.734	1/2	1/2
3-SME-4	3-4 CBZ	3/16	1/4	1.000	.922	.547	.625	.562	.125	.734	1/2	1/2
4-SME-1	4-1 CBZ	1/4	1/16	1.203	.734	.609	.703	.375	.156	.766	9/16	1/2
4-SME-2	4-2 CBZ	1/4	1/8	1.062	.734	.609	.703	.375	.187	.766	9/16	1/2
4-SME-4	4-4 CBZ	1/4	1/4	1.062	.922	.609	.703	.562	.187	.766	9/16	1/2
4-SME-6	4-6 CBZ	1/4	3/8	1.172	1.031	.609	.703	.562	.187	.875	9/16	11/16
4-SME-8	4-8 CBZ	1/4	1/2	1.250	1.312	.609	.703	.750	.187	.969	9/16	13/16
4-SME-12	4-12 CBZ	1/4	3/4	1.546	1.500	.609	.703	.750	.187	1.093	9/16	1-1/16
5-SME-2	5-2 CBZ	5/16	1/8	1.125	.781	.641	.734	.375	.187	.844	5/8	9/16
5-SME-4	5-4 CBZ	5/16	1/4	1.125	.969	.641	.734	.562	.250	.844	5/8	9/16
5-SME-6	5-6 CBZ	5/16	3/8	1.203	1.031	.641	.734	.562	.250	.906	5/8	11/16
6-SME-2	6-2 CBZ	3/8	1/8	1.203	.812	.656	.766	.375	.187	.906	11/16	5/8
6-SME-4	6-4 CBZ	3/8	1/4	1.203	1.000	.656	.766	.562	.281	.906	11/16	5/8
6-SME-6	6-6 CBZ	3/8	3/8	1.234	1.031	.656	.766	.562	.281	.937	11/16	11/16

*NOTE: All dimensions subject to change, to be used for reference only.

¹ The E dimension is the minimum opening. These fittings may have a larger opening at the pipe/straight thread end.

Male Elbow

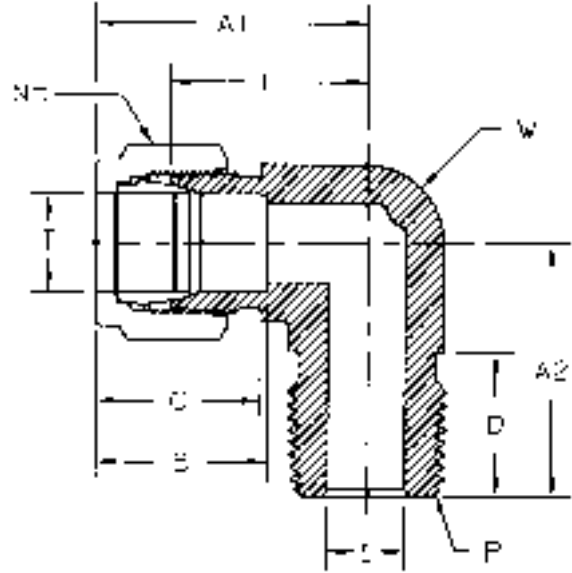

PART NUMBER	INTERCHANGES WITH	T TUBE O.D.	P PIPE END NPT	A1	A2	B	C	D	E ¹ THRU HOLE	L	NH NUT HEX	W WRENCH FLAT
6-SME-8	6-8 CBZ	3/8	1/2	1.312	1.297	.656	.766	.750	.281	1.016	11/16	13/16
6-SME-12	6-12 CBZ	3/8	3/4	1.469	1.453	.656	.766	.750	.281	1.172	11/16	1-1/16
8-SME-2	8-2 CBZ	1/2	1/8	1.609	.937	.906	.859	.375	.187	1.009	7/8	13/16
8-SME-4	8-4 CBZ	1/2	1/4	1.422	1.109	.906	.859	.562	.281	1.016	7/8	13/16
8-SME-6	8-6 CBZ	1/2	3/8	1.422	1.109	.906	.859	.562	.375	1.016	7/8	13/16
8-SME-8	8-8 CBZ	1/2	1/2	1.422	1.297	.906	.859	.750	.406	1.016	7/8	13/16
8-SME-12	8-12 CBZ	1/2	3/4	1.578	1.453	.906	.859	.750	.406	1.172	7/8	1-1/16
10-SME-4	10-4 CBZ	5/8	1/4	1.498	1.125	.969	.859	.562	.281	1.093	1	1
10-SME-6	10-6 CBZ	5/8	3/8	1.500	1.187	.969	.859	.562	.375	1.109	1	15/16
10-SME-8	10-8 CBZ	5/8	1/2	1.500	1.375	.969	.859	.750	.469	1.109	1	15/16
10-SME-12	10-12 CBZ	5/8	3/4	1.578	1.453	.969	.859	.750	.500	1.172	1	1-1/16
10-SME-16	10-16 CBZ	5/8	1	1.780	1.844	.969	.859	.937	.500	1.375	1	1-1/2
12-SME-4	12-4 CBZ	3/4	1/4	1.576	1.250	.969	.859	.562	.281	1.172	1-1/4	1-1/16
12-SME-6	12-6 CBZ	3/4	3/8	1.576	1.250	.969	.859	.562	.406	1.172	1-1/4	1-1/16
12-SME-8	12-8 CBZ	3/4	1/2	1.561	1.453	.969	.859	.750	.469	1.172	1-1/8	1-1/16
12-SME-12	12-12 CBZ	3/4	3/4	1.578	1.453	.969	.859	.750	.625	1.172	1-1/8	1-1/16
14-SME-12	14-12 CBZ	7/8	3/4	1.766	1.641	1.016	.859	.750	.625	1.359	1-1/4	1-3/8
16-SME-4	16-4 CBZ	1	1/4	1.935	1.375	1.234	1.047	.562	.281	1.453	1-1/2	1-1/2
16-SME-8	16-8 CBZ	1	1/2	1.935	1.562	1.234	1.047	.750	.500	1.453	1-1/2	1-1/2
16-SME-12	16-12 CBZ	1	3/4	1.937	1.641	1.234	1.047	.937	.625	1.453	1-1/2	1-3/8
16-SME-16	16-16 CBZ	1	1	1.937	1.828	1.234	1.047	.937	.875	1.453	1-1/2	1-3/8

*NOTE: All dimensions subject to change, to be used for reference only.

¹ The E dimension is the minimum opening. These fittings may have a larger opening at the pipe/straight thread end.

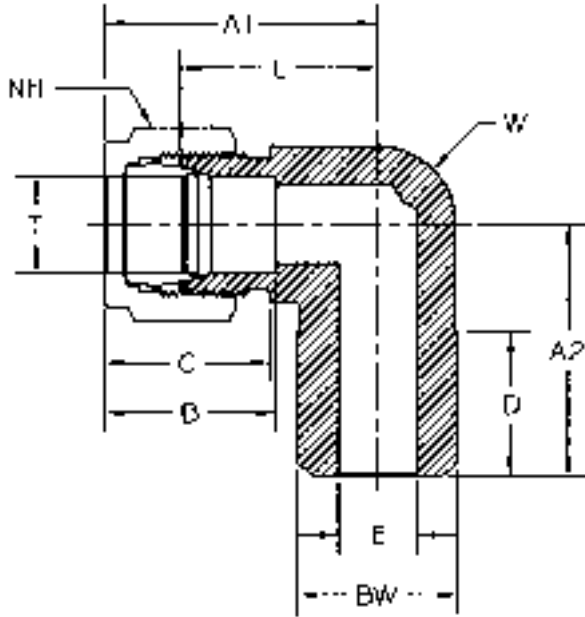

PART NUMBER	INTERCHANGES WITH	T TUBE O.D.	BW	A1	A2	B	C	D	E ¹ THRU HOLE	L	NH NUT HEX	W WRENCH FLAT
2-STBWE-2	2-1/8 ZEBW2	1/8	.405	.922	.719	.516	.609	.344	.094	.656	7/16	1/2
3-STBWE-2	3-1/8 ZEBW2	3/16	.405	1.016	.734	.547	.641	.375	.125	.734	1/2	1/2
4-STBWE-2	4-1/8 ZEBW2	1/4	.405	1.062	.734	.609	.703	.375	.187	.766	9/16	1/2
4-STBWE-4	4-1/4 ZEBW2	1/4	.540	1.062	.937	.609	.703	.562	.187	.766	9/16	1/2
6-STBWE-4	6-1/4 ZEBW2	3/8	.540	1.203	1.000	.656	.766	.562	.281	.906	11/16	5/8
8-STBWE-6	8-3/8 ZEBW2	1/2	.675	1.375	1.125	.906	.859	.562	.406	.969	7/8	13/16
8-STBWE-8	8-1/2 ZEBW2	1/2	.840	1.422	1.297	.906	.859	.750	.406	1.016	7/8	13/16
10-STBWE-8	10-1/2 ZEBW2	5/8	.840	1.437	1.312	.969	.859	.750	.500	1.031	1	7/8
12-STBWE-12	12-3/4 ZEBW2	3/4	1.050	1.578	1.453	.969	.859	.750	.625	1.172	1-1/8	1-1/16
16-STBWE-12	16-3/4 ZEBW2	1	1.050	1.937	1.625	1.234	1.047	.750	.875	1.453	1-1/2	1-3/8
16-STBWE-16	16-1 ZEBW2	1	1.315	1.937	1.844	1.234	1.047	.937	.875	1.453	1-1/2	1-3/8

*NOTE: All dimensions subject to change, to be used for reference only.

¹ The E dimension is the minimum opening. These fittings may have a larger opening at the pipe/straight thread end.

Tube to Socket Weld Elbow

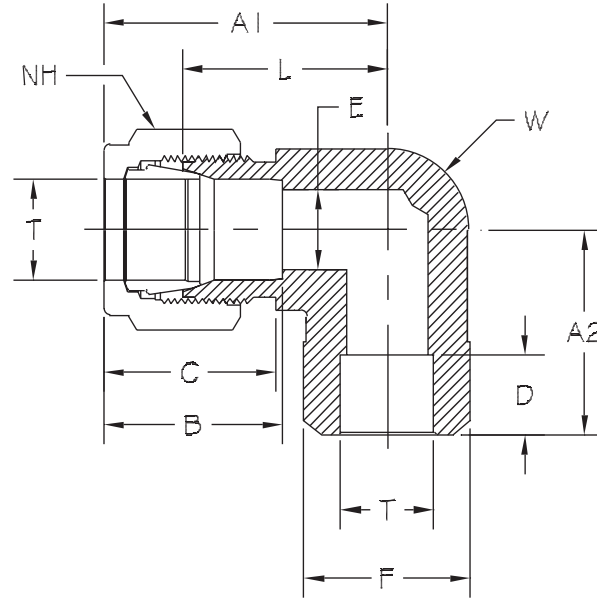

PART NUMBER	INTERCHANGES WITH	T TUBE O.D.	A1	A2	B	C	D	E THRU HOLE	F	L	NH NUT HEX	W WRENCH FLAT
2-STSWE-2	2-2 ZEBW	1/8	.922	.625	.516	.609	.156	.094	.375	.656	7/16	5/16
3-STSWE-3	3-3 ZEBW	3/16	.984	.687	.547	.641	.203	.125	.437	.719	1/2	7/16
4-STSWE-4	4-4 ZEBW	1/4	1.062	.766	.609	.703	.312	.187	.500	.766	9/16	1/2
6-STSWE-6	6-6 ZEBW	3/8	1.203	.906	.656	.766	.375	.281	.625	.875	11/16	5/8
8-STSWE-8	8-8 ZEBW	1/2	1.422	1.016	.906	.859	.500	.406	.812	1.016	7/8	13/16
10-STSWE-10	10-10 ZEBW	5/8	1.562	1.156	.969	.875	.500	.500	.937	1.156	1	1-1/16
12-STSWE-12	12-12 ZEBW	3/4	1.562	1.312	.969	.875	.562	.625	1.094	1.156	1-1/8	1-1/16
16-STSWE-16	16-16 ZEBW	1	1.937	1.469	1.234	1.047	.750	.875	1.375	1.453	1-1/2	1-3/8

*NOTE: All dimensions subject to change, to be used for reference only.

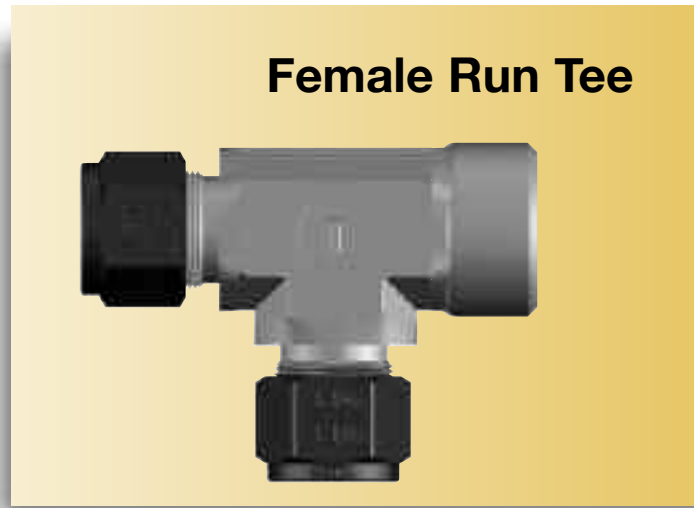
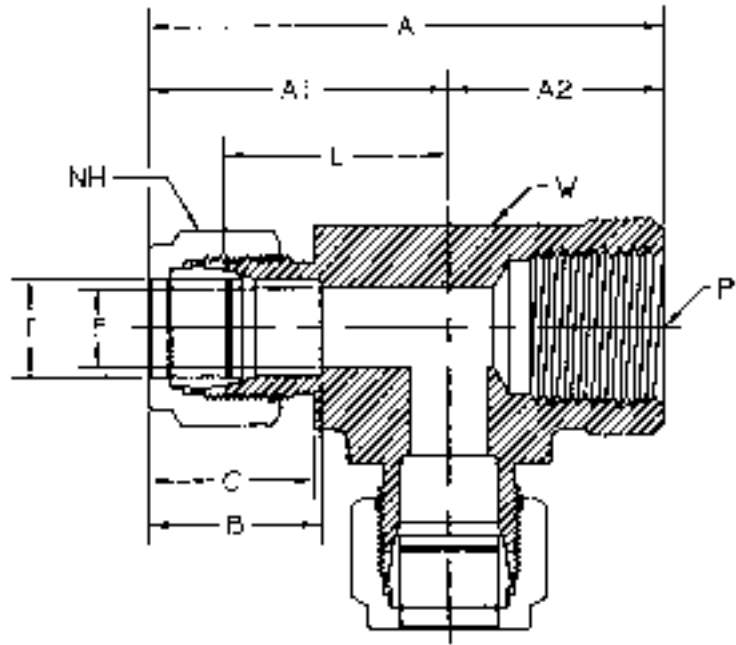

PART NUMBER	INTERCHANGES WITH	T TUBE O.D.	P PIPE END NPT	A	A1	A2	B	C	E THRU HOLE	L	NH NUT HEX	W WRENCH FLAT
2-STFT-2	2-2-2 MBZ	1/8	1/8	1.719	.969	.750	.500	.609	.094	.719	7/16	1/2
3-STFT-2	3-2-3 MBZ	3/16	1/8	1.766	1.016	.750	.547	.641	.125	.750	1/2	9/16
4-STFT-2	4-2-4 MBZ	1/4	1/8	1.812	1.078	.750	.609	.703	.187	.781	9/16	9/16
4-STFT-4	4-4-4 MBZ	1/4	1/4	2.047	1.172	.875	.609	.703	.187	.875	9/16	11/16
5-STFT-2	5-2-5 MBZ	5/16	1/8	1.922	1.172	.750	.641	.734	.250	.875	5/8	5/8
6-STFT-4	6-4-6 MBZ	3/8	1/4	2.109	1.234	.875	.656	.766	.281	.937	11/16	11/16
8-STFT-4	8-4-8 MBZ	1/2	1/4	2.562	1.437	.875	.906	.875	.406	1.016	7/8	13/16
8-STFT-6	8-6-8 MBZ	1/2	3/8	2.297	1.422	.875	.906	.859	.406	1.016	7/8	13/16
8-STFT-8	8-8-8 MBZ	1/2	1/2	2.687	1.578	1.125	.906	.859	.406	1.172	7/8	1-1/16
10-STFT-8	10-8-10 MBZ	5/8	1/2	2.656	1.531	1.125	.969	.875	.500	1.125	1	1-1/16
12-STFT-12	12-12-12 MBZ	3/4	3/4	3.016	1.766	1.250	.969	.859	.625	1.359	1-1/8	1-3/8
14-STFT-12	14-12-14 MBZ	7/8	3/4	3.016	1.766	1.250	1.031	.875	.719	1.359	1-1/4	1-3/8
16-STFT-12	16-12-16 MBZ	1	3/4	3.187	1.937	1.250	1.234	1.047	.875	1.453	1-1/2	1-3/8
16-STFT-16	16-16-16 MBZ	1	1	3.516	2.016	1.500	1.234	1.047	.875	1.531	1-1/2	1-5/8

*NOTE: All dimensions subject to change, to be used for reference only.

Male Run Tee

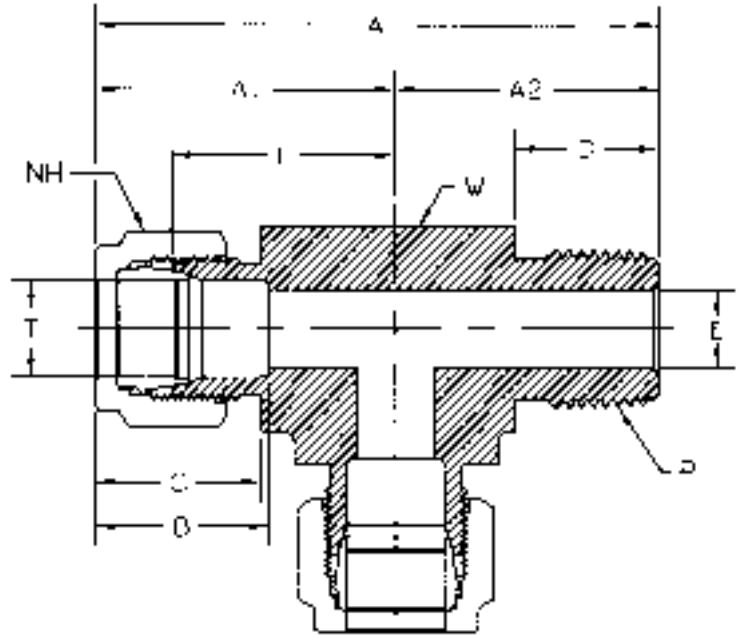

PART NUMBER	INTERCHANGES WITH	T TUBE O.D.	P PIPE END NPT	A	A1	A2	B	C	D	E ¹ THRU HOLE	L	NH NUT HEX	W WRENCH FLAT
2-STMT-2	2-2-2 RBZ	1/8	1/8	1.625	.937	.703	.500	.609	.375	.094	.672	7/16	7/16
3-STMT-2	3-2-3 RBZ	3/16	1/8	1.656	.969	.703	.547	.625	.375	.125	.703	1/2	7/16
4-STMT-2	4-2-4 RBZ	1/4	1/8	1.797	1.062	.734	.609	.703	.375	.187	.766	9/16	1/2
4-STMT-4	4-4-4 RBZ	1/4	1/4	1.984	1.062	.922	.609	.703	.562	.187	.766	9/16	5/8
5-STMT-2	5-2-5 RBZ	5/16	1/8	1.984	1.172	.828	.641	.725	.375	.187	.875	5/8	5/8
6-STMT-4	6-4-6 RBZ	3/8	1/4	2.203	1.203	1.000	.656	.766	.562	.281	.906	11/16	5/8
6-STMT-6	6-6-6 RBZ	3/8	3/8	2.422	1.312	1.109	.656	.766	.562	.281	1.016	11/16	13/16
8-STMT-6	8-6-8 RBZ	1/2	3/8	2.531	1.422	1.109	.906	.859	.562	.375	1.016	7/8	13/16
8-STMT-8	8-8-8 RBZ	1/2	1/2	2.719	1.422	1.297	.906	.859	.750	.406	1.016	7/8	13/16
10-STMT-8	10-8-10 RBZ	5/8	1/2	2.875	1.500	1.375	.969	.859	.750	.469	1.109	1	15/16
12-STMT-12	12-12-12 RBZ	3/4	3/4	3.016	1.578	1.453	.969	.859	.750	.625	1.172	1-1/8	1-1/16
14-STMT-12	14-12-14 RBZ	7/8	3/4	3.266	1.766	1.500	1.031	.875	.750	.625	1.359	1-1/4	1-5/16
16-STMT-12	16-12-16 RBZ	1	3/4	3.609	1.937	1.656	1.234	1.047	.750	.625	1.453	1-1/2	1-5/16
16-STMT-16	16-16-16 RBZ	1	1	3.781	1.937	1.844	1.234	1.047	.937	.875	1.453	1-1/2	1-3/8

*NOTE: All dimensions subject to change, to be used for reference only.

*Both tube ends are typical.

¹ The E dimension is the minimum opening. These fittings may have a larger opening at the pipe/straight thread end.

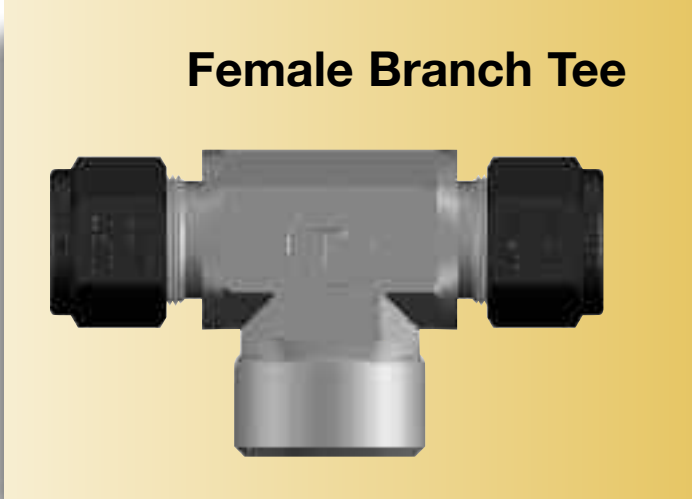
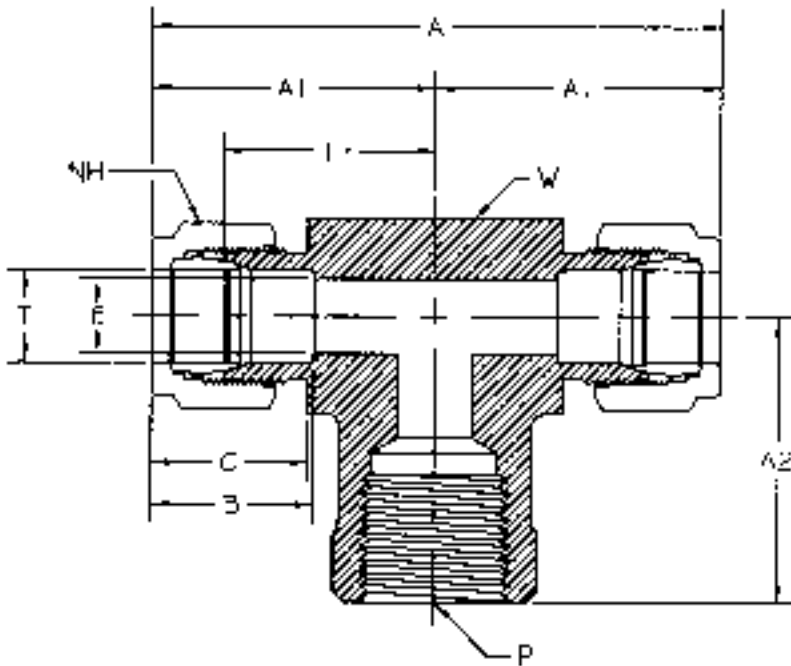

Female Branch Tee

PART NUMBER	INTERCHANGES WITH	T TUBE O.D.	P PIPE END NPT	A	A1	A2	B	C	E THRU HOLE	L	NH NUT HEX	W WRENCH FLAT
2-STTF-2	2-2-2 OBZ	1/8	1/8	1.937	.969	.750	.500	.609	.094	.719	7/16	1/2
3-STTF-2	3-3-2 OBZ	3/16	1/8	2.016	1.016	.750	.547	.641	.125	.750	1/2	1/2
4-STTF-2	4-4-2 OBZ	1/4	1/8	2.125	1.062	.750	.609	.703	.187	.766	9/16	1/2
4-STTF-4	4-4-4 OBZ	1/4	1/4	2.344	1.172	.875	.609	.703	.187	.875	9/16	11/16
5-STTF-2	5-5-2 OBZ	5/16	1/8	2.344	1.172	.750	.641	.734	.250	.875	5/8	5/8
6-STTF-4	6-6-4 OBZ	3/8	1/4	2.469	1.234	.875	.656	.766	.281	.937	11/16	11/16
8-STTF-4	8-8-4 OBZ	1/2	1/4	2.844	1.422	.875	.906	.859	.406	1.016	7/8	13/16
8-STTF-6	8-8-6 OBZ	1/2	3/8	2.844	1.422	.875	.906	.859	.406	1.016	7/8	13/16
8-STTF-8	8-8-8 OBZ	1/2	1/2	3.062	1.531	1.125	.906	.859	.406	1.125	7/8	1-1/16
10-STTF-8	10-10-8 OBZ	5/8	1/2	3.062	1.531	1.125	.969	.859	.500	1.125	1	1-1/16
12-STTF-12	12-12-12 OBZ	3/4	3/4	3.516	1.766	1.250	.969	.859	.625	1.359	1-1/8	1-3/8
14-STTF-12	14-14-12 OBZ	7/8	3/4	3.016	1.766	1.250	1.031	.875	.719	1.359	1-1/4	1-3/8
16-STTF-12	16-16-12 OBZ	1	3/4	3.859	1.937	1.250	1.234	1.047	.875	1.453	1-1/2	1-3/8
16-STTF-16	16-16-16 OBZ	1	1	3.969	1.984	1.500	1.234	1.047	.875	1.500	1-1/2	1-5/8

*NOTE: All dimensions subject to change, to be used for reference only.

*Both tube ends are typical.

Male Branch Tee

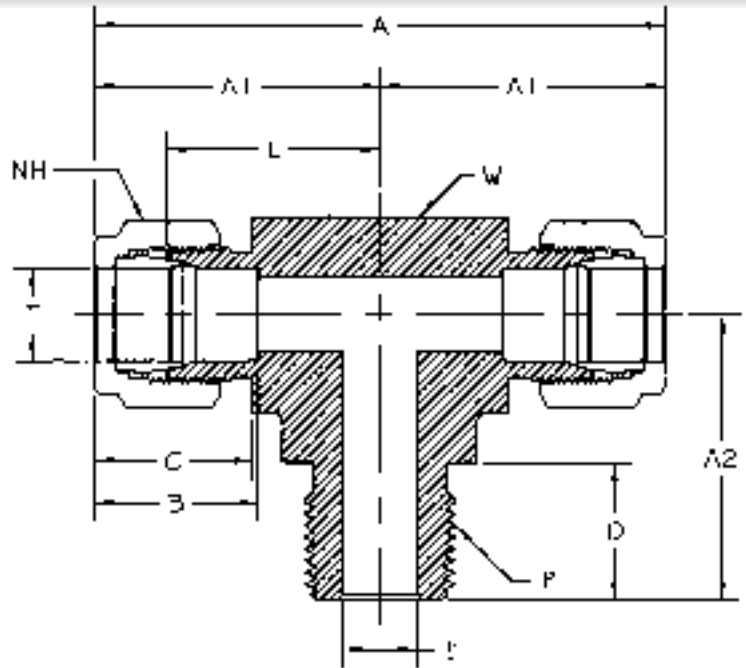

PART NUMBER	INTERCHANGES WITH	T TUBE O.D.	P PIPE END NPT	A	A1	A2	B	C	D	E ¹ THRU HOLE	L	NH NUT HEX	W WRENCH FLAT
2-STTM-2	2-2-2 SBZ	1/8	1/8	1.859	.937	.703	.500	.609	.375	.094	.672	7/16	7/16
2-STTM-4	2-2-4 SBZ	1/8	1/4	1.937	.969	.922	.500	.609	.562	.094	.719	7/16	1/2
3-STTM-2	3-3-2 SBZ	3/16	1/8	1.922	.969	.703	.547	.625	.375	.125	.703	1/2	7/16
4-STTM-2	4-4-2 SBZ	1/4	1/8	2.125	1.062	.734	.609	.703	.375	.187	.765	9/16	1/2
4-STTM-4	4-4-4 SBZ	1/4	1/4	2.125	1.062	.922	.609	.703	.562	.187	.765	9/16	1/2
5-STTM-2	5-5-2 SBZ	5/16	1/8	2.344	1.172	.828	.641	.725	.375	.187	.875	5/8	5/8
6-STTM-4	6-6-4 SBZ	3/8	1/4	2.406	1.203	1.000	.656	.765	.562	.281	.906	11/16	5/8
6-STTM-6	6-6-6 SBZ	3/8	3/8	2.625	1.312	1.109	.656	.765	.562	.281	1.016	11/16	13/16
8-STTM-6	8-8-6 SBZ	1/2	3/8	2.844	1.422	1.109	.906	.859	.562	.375	1.016	7/8	13/16
8-STTM-8	8-8-8 SBZ	1/2	1/2	2.844	1.422	1.297	.906	.859	.750	.406	1.016	7/8	13/16
10-STTM-8	10-10-8 SBZ	5/8	1/2	3.062	1.531	1.406	.969	.859	.750	.469	1.125	1	1
12-STTM-12	12-12-12 SBZ	3/4	3/4	3.141	1.172	1.453	.969	.859	.750	.625	1.172	1-1/8	1-1/16
14-STTM-12	14-14-12 SBZ	7/8	3/4	3.516	1.766	1.500	1.031	.875	.750	.750	1.359	1-1/4	1-3/8
16-STTM-12	16-16-12 SBZ	1	3/4	3.875	1.937	1.656	1.234	1.047	.750	.625	1.453	1-1/2	1-3/8
16-STTM-16	16-16-16 SBZ	1	1	3.875	1.937	1.843	1.234	1.047	.937	.875	1.453	1-1/2	1-3/8

*NOTE: All dimensions subject to change, to be used for reference only.

*Both tube ends are typical.

¹ The E dimension is the minimum opening. These fittings may have a larger opening at the pipe/straight thread end.

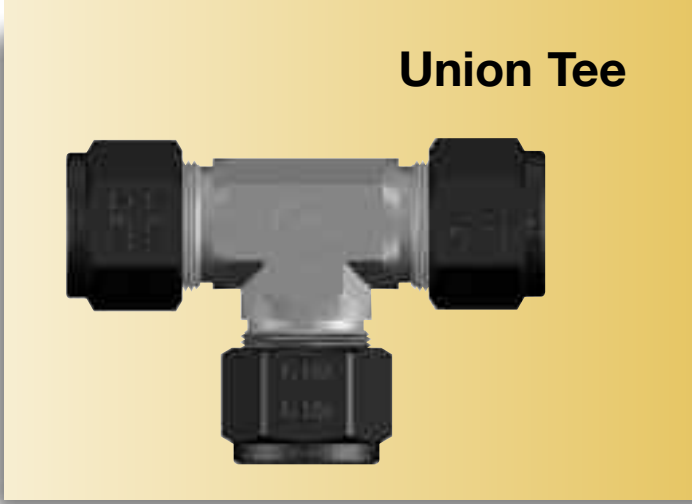
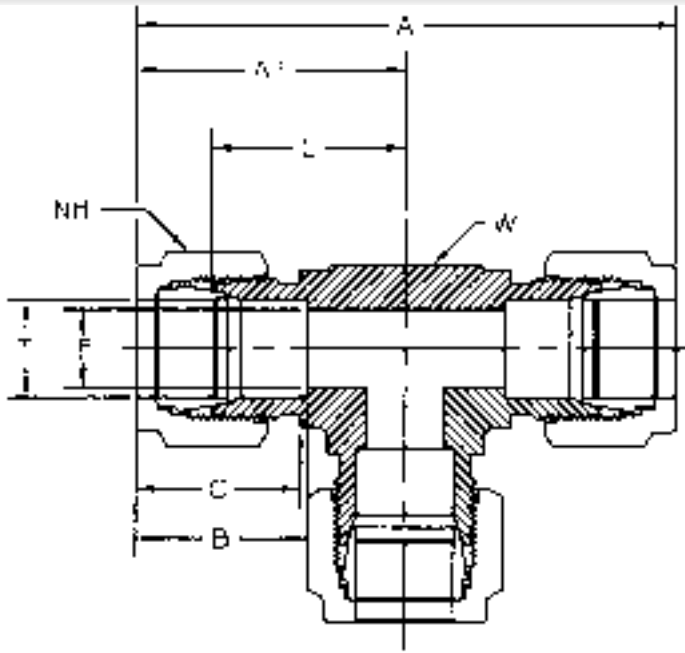

Union Tee

PART NUMBER	INTERCHANGES WITH	T TUBE O.D.	A	A1	B	C	E THRU HOLE	L	NH NUT HEX	W WRENCH FLAT
1-STTT-1	1-1-1 JBZ	1/16	1.406	.703	.344	.437	.052	.547	5/16	3/8
2-STTT-2	2-2-2 JBZ	1/8	1.766	.875	.500	.609	.094	.625	7/16	3/8
3-STTT-3	3-3-3 JBZ	3/16	1.922	.969	.547	.625	.125	.703	1/2	7/16
4-STTT-4	4-4-4 JBZ	1/4	2.125	1.062	.609	.703	.187	.766	9/16	1/2
5-STTT-5	5-5-5 JBZ	5/16	2.344	1.172	.641	.734	.250	.875	5/8	5/8
6-STTT-6	6-6-6 JBZ	3/8	2.406	1.203	.656	.766	.281	.906	11/16	5/8
8-STTT-8	8-8-8 JBZ	1/2	2.844	1.422	.906	.859	.406	1.016	7/8	13/16
10-STTT-10	10-10-10 JBZ	5/8	3.062	1.531	.969	.859	.500	1.125	1	1-1/16
12-STTT-12	12-12-12 JBZ	3/4	3.141	1.578	.969	.859	.625	1.172	1-1/8	1-1/16
14-STTT-14	14-14-14 JBZ	7/8	3.516	1.766	1.016	.859	.718	1.359	1-1/4	1-3/8
16-STTT-16	16-16-16 JBZ	1	3.859	1.937	1.234	1.047	.875	1.453	1-1/2	1-3/8

*NOTE: All dimensions subject to change, to be used for reference only.

*All tube ends are typical.

Union Cross

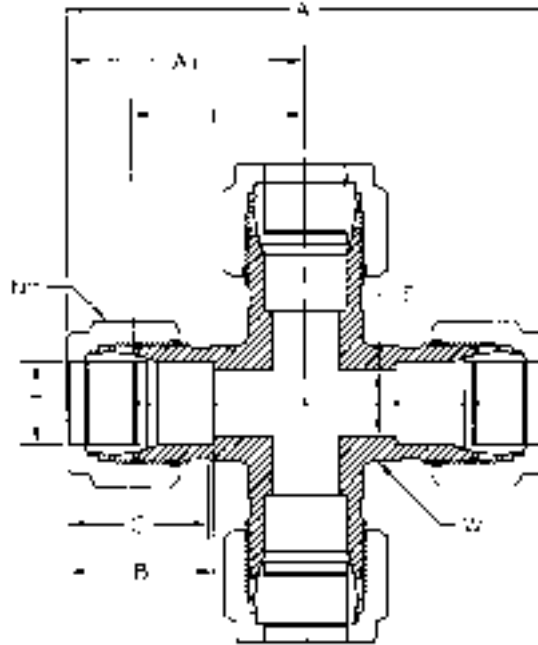
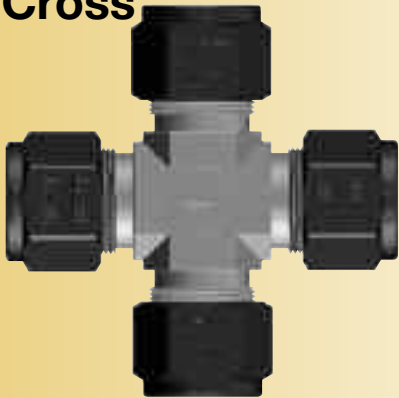

PART NUMBER	INTERCHANGES WITH	T TUBE O.D.	A	A1	B	C	E THRU HOLE	L	NH NUT HEX	W WRENCH FLAT
2-SCR	2-2-2 KBZ	1/8	1.766	.875	.500	.609	.094	.625	7/16	3/8
4-SCR	4-4-4 KBZ	1/4	2.125	1.062	.609	.703	.187	.766	9/16	1/2
5-SCR	5-5-5 KBZ	5/16	2.344	1.172	.641	.734	.250	.875	5/8	5/8
6-SCR	6-6-6 KBZ	3/8	2.406	1.203	.656	.766	.281	.906	11/16	5/8
8-SCR	8-8-8 KBZ	1/2	2.844	1.422	.906	.859	.406	1.016	7/8	13/16
12-SCR	12-12-12 KBZ	3/4	3.016	1.516	.969	.859	.625	1.109	1-1/8	1-1/16
16-SCR	16-16-16 KBZ	1	3.687	1.844	1.234	1.047	.875	1.359	1-1/2	1-3/8

*NOTE: All dimensions subject to change, to be used for reference only.

*All tube ends are typical.

Barbed Insert

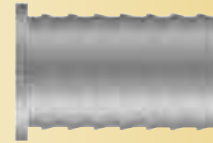
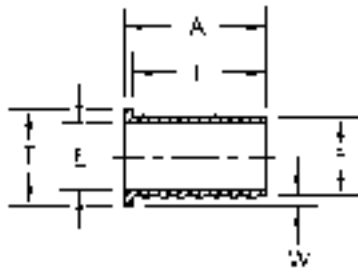

PART NUMBER	T TUBE O.D.	W REF.	A	E THRU HOLE	F TUBE I.D.	L
3-SBI-031	3/16	.031	.566	.062	1/8	.518
4-SBI-022	1/4	.022	.566	.141	13/64	.518
4-SBI-031	1/4	.031	.566	.125	3/16	.518
4-SBI-040	1/4	.040	.566	.109	11/64	.518
4-SBI-062	1/4	.062	.566	.062	1/8	.518
5-SBI-031	5/16	.031	.566	.187	1/4	.518
5-SBI-062	5/16	.062	.566	.125	3/16	.518
5-SBI-094	5/16	.094	.566	.062	1/8	.518
5-SBI-103	5/16	.103	.566	.045	7/64	.518
6-SBI-049	3/8	.049	.566	.218	9/32	.518
6-SBI-062	3/8	.062	.566	.187	1/4	.518
6-SBI-094	3/8	.094	.566	.125	3/16	.518
6-SBI-159	3/8	.159	.566	.032	1/16	.518
8-SBI-035	1/2	.035	.750	.375	7/16	.702
8-SBI-049	1/2	.049	.750	.344	13/32	.702
8-SBI-062	1/2	.062	.750	.312	3/8	.702
8-SBI-125	1/2	.125	.750	.187	1/4	.702
10-SBI-049	5/8	.049	.750	.469	17/32	.702
10-SBI-062	5/8	.062	.750	.437	1/2	.702
10-SBI-125	5/8	.125	.750	.312	3/8	.702
10-SBI-187	5/8	.187	.750	.187	1/4	.702
12-SBI-049	3/4	.049	.750	.562	21/32	.702
12-SBI-062	3/4	.062	.750	.562	5/8	.702
12-SBI-125	3/4	.125	.750	.437	1/2	.702
14-SBI-049	7/8	.049	1.031	.687	25/32	.938
14-SBI-062	7/8	.062	1.031	.687	3/4	.938
14-SBI-125	7/8	.125	1.031	.562	5/8	.938
16-SBI-062	1	.062	1.031	.812	7/8	.938
16-SBI-125	1	.125	1.031	.687	3/4	.938

*NOTE: All dimensions subject to change, to be used for reference only.

Plane Insert

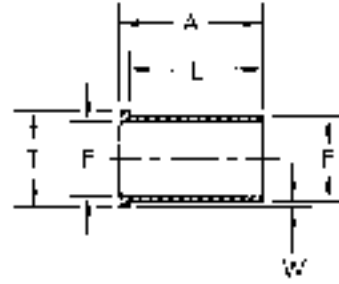

PART NUMBER	T TUBE O.D.	W REF.	A	E THRU HOLE	F TUBE I.D.	L
3-SPI-031	3/16	.031	.566	.062	1/8	.518
4-SPI-022	1/4	.022	.566	.140	13/64	.518
4-SPI-031	1/4	.031	.566	.125	3/16	.518
4-SPI-040	1/4	.040	.566	.109	11/64	.518
5-SPI-062	5/16	.062	.566	.125	3/16	.518
5-SPI-094	5/16	.094	.566	.062	1/8	.518
6-SPI-049	3/8	.049	.566	.218	9/32	.518
6-SPI-062	3/8	.062	.566	.187	1/4	.518
6-SPI-094	3/8	.094	.566	.125	3/16	.518
8-SPI-035	1/2	.035	.750	.375	7/16	.702
8-SPI-049	1/2	.049	.750	.344	13/32	.702
8-SPI-062	1/2	.062	.750	.312	3/8	.702
8-SPI-125	1/2	.125	.750	.187	1/4	.702
10-SPI-049	5/8	.049	.750	.469	17/32	.702
10-SPI-062	5/8	.062	.750	.437	1/2	.702
10-SPI-125	5/8	.125	.750	.312	3/8	.702
12-SPI-049	3/4	.049	.750	.562	21/32	.702
12-SPI-062	3/4	.062	.750	.562	5/8	.702
12-SPI-125	3/4	.125	.750	.437	1/2	.702
14-SPI-049	7/8	.049	1.000	.687	25/32	.952
14-SPI-062	7/8	.062	1.000	.687	3/4	.952
14-SPI-125	7/8	.125	1.000	.562	5/8	.952
16-SPI-050	1	.050	1.000	.843	57/64	.952
16-SPI-062	1	.062	1.000	.812	7/8	.952
16-SPI-125	1	.125	1.000	.687	3/4	.952

*NOTE: All dimensions subject to change, to be used for reference only.

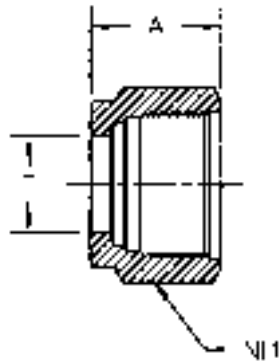

Nut



PART NUMBER	INTERCHANGES WITH	T TUBE O.D.	A	NH NUT HEX
SN-1	1 BZ	1/16	.312	5/16
SN-2	2 BZ	1/8	.469	7/16
SN-3	3 BZ	3/16	.469	1/2
SN-4	4 BZ	1/4	.500	9/16
SN-5	5 BZ	5/16	.531	5/8
SN-6	6 BZ	3/8	.562	11/16
SN-8	8 BZ	1/2	.687	7/8
SN-10	10 BZ	5/8	.687	1
SN-12	12 BZ	3/4	.687	1-1/8
SN-14	14 BZ	7/8	.687	1-1/4
SN-16	16 BZ	1	.812	1-1/2

*NOTE: All dimensions subject to change, to be used for reference only.

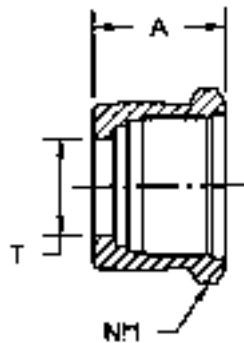

Knurled Nut

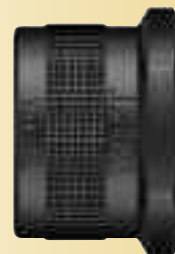

The knurled nut is used with fittings where applications of a finger tight assembly is acceptable. Common applications include, but are not limited to, low pressure laboratory use on plastic tubing.

Knurled nuts are available in the same sizes as shown for CS-Lok® nuts (SN). The knurled nut part descriptor is SKN. For example, the part number for a 1/2" knurled nut is SS-SKN-8.

Single Collet (Ferrule)

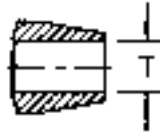

For sizes 1-6

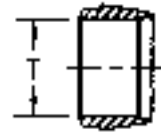

For sizes 8-16

PART NUMBER	INTERCHANGES WITH	T TUBE O.D.
SC-1	1 TZ	1/16
SC-2	2 TZ	1/8
SC-3	3 TZ	3/16
SC-4	4 TZ	1/4
SC-5	5 TZ	5/16
SC-6	6 TZ	3/8
SC-8	8 TZ	1/2
SC-10	10 TZ	5/8
SC-12	12 TZ	3/4
SC-14	14 TZ	7/8
SC-16	16 TZ	1

*NOTE: All dimensions subject to change, to be used for reference only.

Component Replacement Parts

Collet sets and Nut/Collet sets make for easy storage and handling of nuts and single collets. CS-Lok® component parts are precision made and should be handled with care. The components can be ordered on an arbor, which aids in careful handling and prevents them from coming off. Pinch the end of the arbor to release the components.

Collet Sets contain 10 collets on an arbor.
1/2" Collet Set part number: SS-SCSET-8-10

Collet Sets



PART NUMBER	INTERCHANGES WITH	TUBE O.D.	QUANTITY (per arbor)
SCSET-4-10	4 CPI-SET	1/4	10
SCSET-6-10	6 CPI-SET	3/8	
SCSET-8-10	8 CPI-SET	1/2	
SCSET-12-10	12 CPI-SET	3/4	
SCSET-16-10	16 CPI-SET	1	

Nut/Collet Sets contain 5 nuts & 5 collets on an arbor.
1/2" Nut/Collet Set part number: SS-SNCSET-8-5

Nut/Collet Sets



PART NUMBER	TUBE O.D.	QUANTITY (per arbor)
SNCSET-4-5	1/4	5
SNCSET-6-5	3/8	
SNCSET-8-5	1/2	
SNCSET-12-5	3/4	
SNCSET-16-5	1	

Instrument Tee

The Instrument Tee may be ordered with any standard tube or pipe size. When ordering, specify sizes in the following order:

1. Tube Size O.D
2. Female Pipe Size
3. Male Pipe Size

Example: 1/2" tube, 3/8" female pipe, 1/4" male pipe.
SS-8-STFM-6-4



Heat Exchanger Tee

The Heat Exchanger Tee may be ordered in any standard tube size. The process tube is bored through. When ordering, specify sizes in the following order:

1. Jacket Tube O.D
2. Process Tube O.D. followed by "BT" for bore through designation
3. Branch Tube O.D.

Example: 1/2" tube, 1/4" tube bored through, 1/2" tube.
SS-8-STTT-4BT-8



Thermocouple Bore Through

A Thermocouple Connector can be furnished already bored through for an additional charge. When ordering:

1. Select required size male connector. See pages 13 and 14 for a listing of available Male Connectors.

2. Add the letters "BT" to designate bore through.

Example: 4-SMC-2-BT



Tylube™ Thread Lubricant

Tylube™ is an anti-gall compound to be used on stainless steel, steel and nickel based alloys. Temperature range to 500°F. Not recommended for plastic and aluminum products. Tylube™ is made from distilled water with inert ingredients and contains no silicones, heavy metals, chlorine or sulfur. For a complete list of ingredients request an MSDS to be sure of its compatibility with your installation. Available in 8 oz. plastic bottles.



CS-Lok® Installation Instructions

CS-Lok® Tube Fittings come completely assembled and ready for use, no disassembly required. Although there are some general guide lines to follow no special preparation of the tubing is necessary, reference page 43. In overhead applications Tylok recommends using a Pre-Set Tool, see page 46.

Size		Tighten # Turn(s)
1	1/16"	3/4
2	1/8"	
3	3/16"	
4	1/4"	1-1/4
5	5/16"	
6	3/8"	
8	1/2"	
10	5/8"	
12	3/4"	
14	7/8"	
16	1"	

Size #1 Thru #3
(1/16" - 3/16")

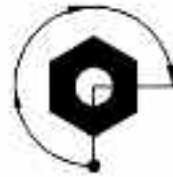

Finger Tight Plus
3/4 Turn

Size #4 Thru #16
(1/4" - 1")

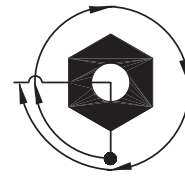

Finger Tight Plus
1-1/4 Turns

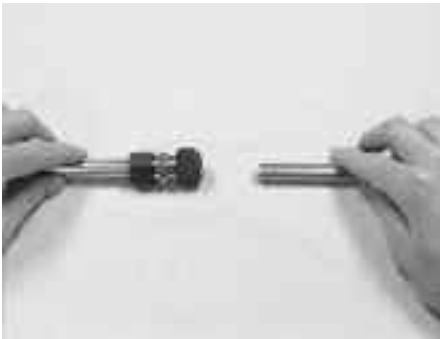

Simply insert the tubing into the assembly making sure the tubing seats firmly against the shoulder of the body and the nut is finger tight.



Tighten nut with wrench an additional number of turns indicated above, while holding the fitting body with a second wrench.

To Remove Tube and Re-Connect Tube Fitting

Mark the location of the nut with reference to the body before disassembly. For reassembly, re-insert the tubing into the body until it is seated. With proper size wrench, retighten nut to original location by realigning previous marks. A noticeable amount of torque will develop when the nut is turned to original position. Next, rotate the nut slightly past original position to fully re-set the seal.



Mark the location of the nut with reference to the body.



Back off the nut until it is clear of the body and remove the tubing from the fitting.

CS-Lok® Tubing Selection & Preparation

Proper selection of tubing is key to the performance of the fitting. When selecting the proper wall thickness and material, all tubing should be compatible with the process fluid, temperature, application, flow and system pressure.

For proper sealing it is recommended that the tubing and fitting be of like material to allow for positive sealing (i.e., stainless on stainless, brass on copper, steel on steel). Galvanic corrosion could occur if the tubing and fitting are not of like material, with the exception of a brass fitting on copper tubing.

When using stainless steel tubing, Tylok recommends using Type 304 or 316 fully annealed, seamless or welded redrawn meeting ASTM-A-213, ASTM-A-269 or equivalent, with a suggested maximum hardness of 80 Rb.

For copper tubing, Tylok suggests using soft annealed, seamless tubing per ASTM-B75 or equivalent. Copper water tube type K or L, soft annealed (Temper O) per ASTM-B88 can also be used.

When using carbon steel, all tubing should be fully annealed and conform to ASTM-A-179, or equivalent, with a maximum hardness of 72 Rb.

In general, all tubing should be free of nicks, scratches, imperfections of any kind and be suitable for bending. Out of round tubing that does not easily go through fitting components should not be used. It is recommended that the charts be used for tube selection. Ideally, the tube end should be cut square so that when it bottoms out inside the fitting an extra seal is provided. Avoid installing contaminated tubing into your system. For elevated temperatures see page 45.

CS-Lok® Tube Fittings swage the tubing to achieve its seals. Thin wall tubing (wall thicknesses with working pressures highlighted in reverse text, in the charts) is not recommended for Gas Service. For Gas Service see page 44.

When using tubing of a thinner or thicker wall than shown, it is always recommended that you consult with your local Distributor or contact Tylok International directly if there is any doubt selecting tubing.

Values in reverse text are not recommended for Gas Service.

Note: Tables, calculated to the right, are suggested maximum working pressure ratings, in accordance with ASME B31.3, but should be used for reference only. Tylok International, Inc., is not responsible for its accuracy nor designs using these figures. All compatible Tylok fittings will withstand pressures above those listed for maximum tubing working pressures.

It is the responsibility of the Engineer to refer to the technical pages in this catalog to ensure selection of the proper tubing material, tubing compatibility with the fitting, media and tubing wall thickness. Following the stated recommendations will ensure a safe application, free of leaks. The entire system must be considered when selecting the fitting.

SUGGESTED ALLOWABLE WORKING PRESSURE TABLES (psig)

Stainless Steel								
Tube Size O.D.	Tube Wall Thickness (inches)							
	.028	.035	.049	.065	.083	.095	.109	.120
1/8"	8400	10600						
3/16"	5500	7000	10100					
1/4"	4000	5100	7500	10100				
5/16"		4100	5900	8000				
3/8"		3300	4800	6600				
1/2"		2600	3800	5100	6700			
5/8"			3000	4000	5200	6100		
3/4"			2500	3300	4300	5000	5800	
7/8"			2100	2800	3600	4200	4900	
1"				2400	3200	3700	4200	4700

75,000 PSI Tensile
Note: For welded and drawn tubing, a derating factor must be utilized. For double welded tube, multiply the above pressure rating by .85; and for single welded tube by .80 (ANSI B 31, Table A-1B).

Carbon Steel								
Tube Size O.D.	Tube Wall Thickness (inches)							
	.028	.035	.049	.065	.083	.095	.109	.120
1/8"	8100	10200						
3/16"	5200	6700	9600					
1/4"	3800	4900	7100	9600				
5/16"		3800	5500	7600				
3/8"		3100	4500	6200				
1/2"		2300	3300	4500	6000			
5/8"			2600	3500	4600	5300		
3/4"			2200	2900	3800	4400	5100	
7/8"			1800	2500	3200	3700	4300	
1"				2100	2800	3200	3700	4200

47,000 PSI Tensile

Copper								
Tube Size O.D.	Tube Wall Thickness (inches)							
	.028	.035	.049	.065	.083	.095	.109	.120
1/8"	2700	3600						
3/16"	1800	2300	3500					
1/4"	1300	1700	2500	3600				
5/16"		1300	2000	2800				
3/8"		1100	1600	2300				
1/2"		800	1200	1700	2200			
5/8"			900	1300	1700	1900		
3/4"			800	1000	1400	1600	1900	
7/8"			600	900	1100	1300	1600	
1"			500	800	1000	1200	1400	1500

30,000 PSI Tensile

Gas Service

Extra care must be taken when tubing is used in gas service applications. Small gas molecules easily escape through minute leak paths, therefore, the tubing must be free of nicks, scratches and imperfections of any kind. In particular, when using large diameter tubing the possibility of surface defects is increased due to greater surface area. It is strongly recommended that the heavier wall thicknesses be selected. Penetration of the ferrule on thin wall tubing or soft material may not offer enough radial resistance for sealing. In such cases, Tylok recommends using a Plane Insert (Part descriptor SPI, page 38). In the tables on page 43 note the suggested allowable working pressure for gas service.

Values in reverse text are not recommended for Gas Service.

Precautions for Weld Ends

CS-Lok® Tube Fittings with weld ends offer the same positive sealing as all other Tylok fittings. Welding could deform the assembly, making pull ups or disassembly difficult. Some precautions should be taken...

- Remove the nut and ferrule from the fitting
- It is important that the fitting threads and sealing surfaces be protected from weld splatter
- A heat sink should be used to dissipate heat
- Ensure alignment by tack welding symmetrically
- Once welded, remove the weld splatter protection and reassemble nut and ferrule on fitting

Gap Gages

Gap Gages can be purchased to ensure the Installer and Inspector that the nut has been properly tightened. Available upon request.



Part Number	Tube Size	Part Number	Tube Size
#1-SGG	1/16"	#8-SGG	1/2"
#2-SGG	1/8"	#10-SGG	5/8"
#3-SGG	3/16"	#12-SGG	3/4"
#4-SGG	1/4"	#14-SGG	7/8"
#5-SGG	5/16"	#16-SGG	1"
#6-SGG	3/8"	#16-SGG	1/4", 3/8", 1/2"



When fitting is properly tightened, **gap gage should not fit** between nut and shoulder of body.

Safety Guidelines

- Never connect, disconnect or remake a fitting with pressure in the system
- Make sure all fittings are properly installed, reference Installation Instructions - page 42, before pressurizing the system
- Tubing material should be softer than fitting material
- Tylok recommends using Tylok replacement parts
- Although the fittings will hold to the pressure rating of the tubing, it is not recommended to go beyond this rating. Elongation could occur in the tubing, shrinking the wall thickness and causing potential harm to anyone in the area
- Always use proper thread lubricants and sealants on tapered pipe threads
- If process fluids are toxic and/or hazardous, exercise extra caution
- Never bleed a system by loosening a fitting
- For proper sealing it is recommended that the tubing and fitting be of like material

Quality Control

All components are manufactured and inspected to meet strict quality control standards in each phase of production. All employees are thoroughly trained to follow rigid procedures, in accordance with the ISO 9001:2008 Quality Standard, to ensure a quality product from the start of each job through completion. At Tylok our primary concern is quality, reliability and service to our customers.

Tylok Liquid Leak Detectors

TySpy and Cool TySpy liquid leak detectors detect gas leaks in hard-to-reach areas.

- Safe for oxygen systems
- Sustained bubble action works even on very small leaks and vertical surfaces
- Flexible snooter tube extends for hard-to-reach areas
- Formula dries clean, without staining

Part Number	Container Size	Pull Out Tube Length
TYPSY-8oz	8 fl oz. (##ml)	4 inch (#cm)
TYSPY-Gal	1 Gallon	
COOL TYSPY-8oz	8 fl oz. (##ml)	4 inch (#cm)
COOL TYSPY-Gal	1 Gallon	4 inch (#cm)



TYSPY LIQUID LEAK DETECTOR

- **Temperature rating:** Can be used over a temperature range of 27 to 200°F (-2 to 93°C).
- **Specifications:** Meets the performance requirement of:
 - MIL-PRF-25567 Leak Detector Compound, Oxygen Systems, Type I, 1 to 70°C (33 to 158°F).
 - NFPA 52 Section 6-12 Leak Testing Compressed Natural Gas Vehicular Fuel System.
 - EPA Part 60, Appendix A, Method 21, Section 4.3.3 Alternative Screening Procedures Using Soap Solutions.
- Nontoxic, noncorrosive, nonflammable
- Available in 8 oz (236mL) and 1 gal (3.8 L) bottles

COOL TYSPY LIQUID LEAK DETECTOR

- **Temperature rating:** Can be used over a temperature range of -65 to -200F (-54 to -93°).
- **Specifications:** Meets the performance requirement of:
 - MIL-PRF-25567 Leak Detector Compound, Oxygen Systems, Type I, 1 to 70°C (33 to 158°F).
 - NFPA 52 Section 6-12 Leak Testing Compressed Natural Gas Vehicular Fuel System.
 - EPA Part 60, Appendix A, Method 21, Section 4.3.3 Alternative Screening Procedures Using Soap Solutions.
- Nontoxic, noncorrosive, nonflammable
- Available in 8 oz (236mL) and 1 gal (3.8 L) bottles



Heat Traceability

CS-Lok® Tube Fittings are completely heat code traceable back to the original mill heat from which it was made. Starting with the original billet, the mill creates a certificate which completely describes the chemical and physical makeup. For any one of the three components (body, ferrule, nut) the material certifications can be provided when calling Tylok and giving the heat code stamp marked on the part itself, along with the part number.

Raw Material Specifications

Fitting Material	Bar Stock	Forging	*Tubing Specification	Maximum Specification Hardness (Tubing)
Brass	ASTM-B16 Alloy 360 ASTM-B453 Alloy 345	ASTM-B124 Alloy 377	ASTM-B75 Copper (Temper O)	60 Max. Rockwell 15T
Stainless Steel	ASTM-A276 ASME-SA-479 Type 316-SS	ASME-SA-182 Type 316-SS	ASTM-A213 ASTM-A269	90 Rb
Steel	ASTM-A108		ASTM-A179	72 Rb

*Reference Tubing Selection & Preparation, page 43.

Tylok Pre-Setting Tool

The CS-Lok® product line offers a Pre-Setting Tool when fittings need to be installed in hard to reach places. The Pre-Setting Tool is designed to be used in any tabletop vice. After tightening the nut the specified number of turns, as stated in Installation Instructions - page 42, loosen the nut from the Pre-Setting Tool. Once the ferrule has swaged into the tubing surface, the assembly is ready for installation (reference To Remove and Re-Connect Tube Fitting, page 42).

When ordering the CS-Lok® Pre-Set Tool, reference the part number in the chart. The Pre-Set Tool is made from carbon steel and is hardened for maximum durability. The Pre-Set Tool can be used repeatedly to set the ferrule onto the tubing for easy installation.



Part Number	Tube Size
#1-SPST	1/16"
#2-SPST	1/8"
#3-SPST	3/16"
#4-SPST	1/4"
#5-SPST	5/16"
#6-SPST	3/8"
#8-SPST	1/2"
#10-SPST	5/8"
#12-SPST	3/4"
#14-SPST	7/8"
#16-SPST	1"



Place Pre-Setting Tool in a vice and tighten nut specified number of turns.



Back nut off of Pre-Setting Tool. Notice the ferrule has swaged into the tubing. Now take tubing to installation area.

Tube Insertion Chart

For pre-cutting tubing to length, the following chart shows the additional length inside the fitting assembly.

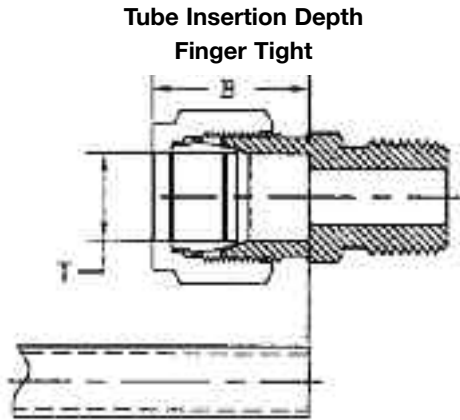

Tube Size	T Tube O.D.	B Dimension
#1	1/16	.34
#2	1/8	.50
#3	3/16	.54
#4	1/4	.60
#5	5/16	.64
#6	3/8	.67
#8	1/2	.90
#10	5/8	.96
#12	3/4	.96
#14	7/8	1.03
#16	1.0	1.24

*NOTE: All Dimensions Subject to Change.

Tubing-General Applications

CS-Lok® Tube Fittings are designed to perform in a variety of applications that demand high performance. The CS-Lok® product line has been engineered to provide optimal performance, however tubing should always be considered as an important factor in the design stages of any system. Below is a table that describes some general uses for different types of materials. The table is provided as a reference to the Engineer in the design process.

Tylok suggests the use of seamless, fully annealed tubing. Welded tubing may be used with Tylok fittings. However, due to the manufacturing of welded tubing, variables may be encountered. The media flowing through the tubing must be compatible with the tubing itself. It is always a good rule to use like tubing material on like fitting material. If this format is not followed, the ferrules may have difficulty penetrating the tubing causing an adverse affect on the sealing ability. In addition, dissimilar materials in contact may be sensitive to galvanic corrosion. Tylok recommends ordering tubing material to meet ASTM specifications to ensure that it will be dimensionally, physically and chemically within precise limits (see Raw Material Specifications chart - page 46).

Tubing Material	General Applications	Recommended Temperature Range
Carbon Steel	Air Lines, High Pressure, High Temperature, Oil, Air, Specialty Chemicals, Hydraulic Gases	-20°F to 400°F*
Copper	Low Temperature, Low Pressure Water, Oil, Air, Pneumatic Controls, Lube Lines	-40°F to 400°F
Stainless Steel	High Pressure, High Temperature, Nitrogen, Helium, Flammable Gases, Hydraulic, Gases, generally corrosive media	-20°F to 1000°F

*Based on 400°F maximum.

Notice

In designing a system incorporating tube fittings and valves, it is the designer's or user's obligation and responsibility to determine the appropriate fittings and valves to be used for each application, and to insure proper installation and maintenance.

Limited Warranty

Tylok fittings and valves are warranted solely against defects in material and workmanship in the performance of the specific functions for which they are designed, as set forth in the published specifications for a period of 12 months. Should any fitting and valve or its component fail due to a defect in material or workmanship, Tylok will replace said fitting and valve without charge upon return of the failed part and evidence of its failure being due to materials or workmanship.

The Warranty above set forth is the only warranty applicable to Tylok products, and is in lieu of any and all other warranties either express or implied, including any warranty of merchantability or fitness. Tylok's sole responsibility or liability as a result of any loss or damage due to failure shall be to replace the failed part or fitting and valve, and it shall bear no liability for any incidental or consequential damages to person or property.



Our History

In the mid 1940s, Cullen Crawford founded the Crawford Fitting Company. Mr. Crawford developed and patented the original flareless fitting (nut and two ferrule system), for the Crawford Fitting Company. Thus, a new and innovative industry was born making it far easier to make tubing connections. This reduces installation time and errors. Since his invention, End Users from all four corners of the globe have made billions of connections. This system provides leak proof seals and thus Mr. Crawford has been named "The founder of the flareless fitting."

Our Mission

It is our mission, at Tylok International, Inc., to continuously strive for and achieve total customer satisfaction with both our products and services.

Our Goal

Tylok's aggressive goal is to establish ourselves as an industry leader and expand our market share. This is maintained in every department within the organization. Our "total effort" will guard against losing the personal touch that makes our business enjoyable and prosperous for all involved.

INSTRUMENTATION TUBE FITTINGS

Tylok Standard

CBC-Lok®

CS-Lok®

PIPE FITTINGS

WELD FITTINGS

BALL VALVES

• **Ty-Flo® HP Series**

• **Ty-Flo® 3 Piece**

TY-FLO® NEEDLE VALVES

MANIFOLDS

FLEXIBLE METAL HOSE

QUICK COUPLERS



1061 East 260th Street • Euclid, Ohio 44132
Tel: (216) 261-7310 • 1-800-321-0466 • Fax: (216) 261-7317
info@tylok.com
www.tylok.com