



CBC LOK[®] TUBE FITTINGS



MADE IN THE U.S.A.



Oct. 18, 1949.

C. B. CRAWFORD

2,484,815

TUBE COUPLING

Filed Aug. 15, 1947

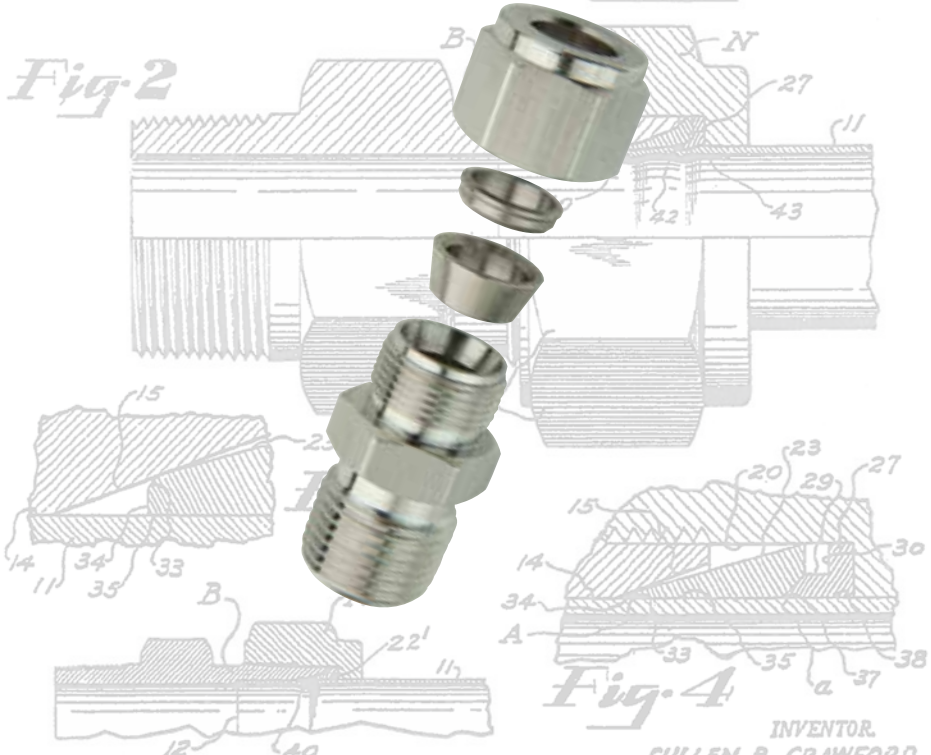
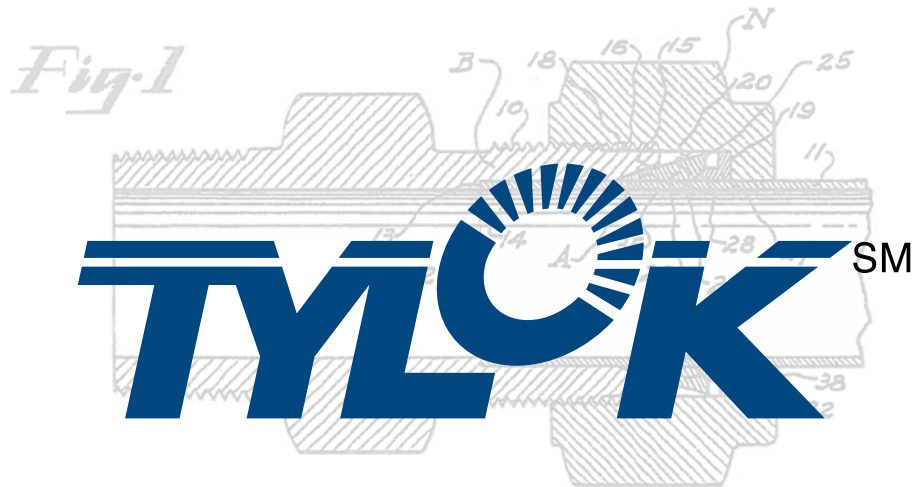

INVENTOR.
 CULLEN B. CRAWFORD
 BY *Jay, Colrick & Jay*
 ATTORNEYS

REGISTRATIONS & TYPE APPROVALS



Canadian Registration



Creation of an Industry

In the mid 1940s, Cullen Crawford developed and patented the original flareless fitting (nut and double ferrule system), making it easier and more efficient to make tubing connections. Based on this innovation he founded the Crawford Fitting Company creating an industry for compression fittings.

At Tylok, our mission is total customer satisfaction with both products and services. Our knowledgeable staff is readily available to answer questions and respond in a timely manner. We continue to develop new products that expand the Tylok brand. If you have a unique product need, Tylok would like to be your engineered solutions provider.

Introduction

CBC-Lok® tube fittings are fully interchangeable with Swagelok® and Parker A-Lok®. Although it is always recommended to use all CBC-Lok® components, intermixing CBC-Lok® bodies and/or component parts with that of other manufacturers will not adversely affect sealing ability. CBC-Lok® Tube Fittings are made to strict quality control standards. CBC-Lok® Tube Fittings are proudly made in the U.S.A.

Operation

CBC-Lok® Tube Fittings are comprised of four components: Body, Front Ferrule (Collet), Rear Ferrule (Collet) and Nut. A leak proof seal is obtained through proper ferrule action as the ferrules are tightened onto the tubing via axial thrust provided by the nut. The front ferrule provides the leak proof seal, when the nut and ferrules are properly drawn up the specified number of turns. The rear ferrule grips the tubing preventing pull-off. The stainless steel nuts are silver plated and a dry film lubricant is applied, reducing torque and ensuring proper sealing.

Ty-Cor™ Process

Ty-Cor™ refers to the treatment that diffuses carbon into the surface of the stainless steel, thereby increasing the surface hardness without affecting the quality of the metal treated. In fact, when AISI 316 stainless steel is treated, the corrosion resistance is equal to or better than non-treated 316 stainless steel. The increase in corrosion resistance to pitting and stress corrosion is very pronounced in media that contain chlorides (e.g. sea water, bleach, HCl, etc.). The Ty-Cor™ process applied to the rear ferrule also helps eliminate galling and ensures proper sealing on tube end make ups.

Features

- Double ferrule swaging action
- Total component interchangeability
- Heat Code traceable
- ASTM material construction
- Corrosion resistant 316 Stainless Steel rear ferrules

SAI Global has registered Tylok International's Quality Management System to ISO 9001:2008. The quality system complies with the international standard ISO 9001:2008 and its technical equivalent, ANSI/ISO/ASQ Q9001:2008. Tylok strives to continuously improve the effectiveness of the Quality Management System by each member within the organization.

Table of Contents/Product Locator

HOW TO ORDER

How To Order

4



DATANF

Adapter Tube to AN Flare

5



DATPF

Adapter Tube to Female Pipe

6



DATPM

Adapter Tube to Male Pipe

7

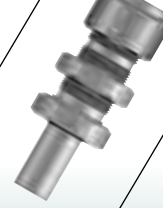

DBHA

Bulkhead Adapter

8

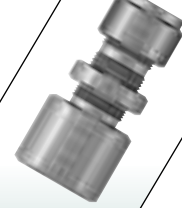

DBHFP

Bulkhead Female Pipe Connector

9



DBHMP
Bulkhead Male Pipe Connector

10

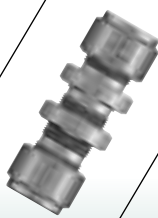

DBHU
Bulkhead Union

11



DBUANF
Bulkhead to AN Flare Union

11



DCAP
Cap

12

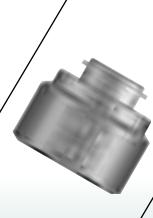

DF PLUG
Fitting Plug

12



DFC
Female Connector

13



DMC
Male Connector

14 & 15



DMC-ORS
O-Ring Straight Thread Male Conn.

16



DMC-ORT
O-Ring Pipe Thread Male Conn.

18



DMC-STB
Straight Thread Boss Male Connector

19



DPCU
Port Connector Union

20



DRATT
Reducer Adapter Tube to Tube

21



DRPC
Reducing Port Connector

22



DRU
Reducing Union

23

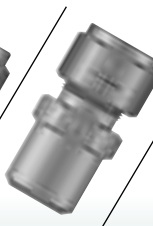

DTBW
Tube to Butt Weld Connector

24



DTSW
Tube to Socket Weld Connector

25



DU
Union

26



DUANF
Tube to AN Flare Union

27

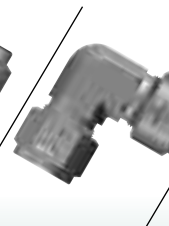

DELU
Union Elbow

28

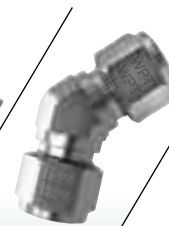

DELU45
Union 45° Elbow

29

Table of Contents/Product Locator



DFE
Female
Elbow

30

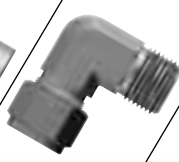

DME
Male Elbow

31 & 32

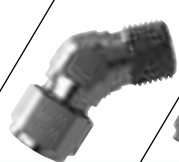

DME45
Male
45° Elbow

33

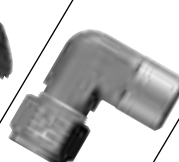

DTBWE
Tube to Butt
Weld Elbow

34



DTSWE
Tube to
Socket Weld
Elbow

35

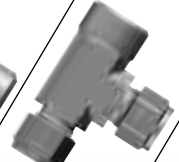

DTFT
Female Run
Tee

36

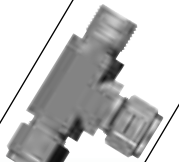

DTMT
Male Run
Tee

37

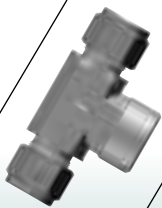

DTTF
Female
Branch Tee

38

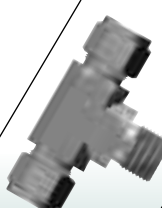

DTTM
Male
Branch Tee

39

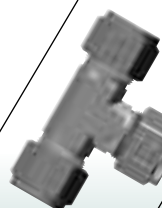

DTTT
Union Tee

40



DCR
Union Cross

41

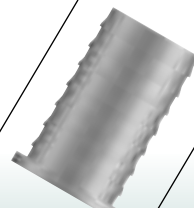

DBI
Barbed
Insert

42

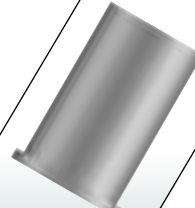

DPI
Plane
Insert

42



DN
Nut

43



DKN
Knurled Nut

43

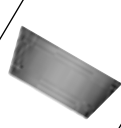

DFC
Front Collet
(Ferrule)

44



DRC
Rear Collet
(Ferrule)

44

**COMPONENT
REPLACEMENT
PARTS**

Replacement
Parts

44

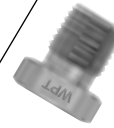

1MDF
Mud Dauber
Fitting

45

**SPECIAL
PRODUCTS**

Special
Products

46

**CBC-LOK®
INSTALLATION
INSTRUCTIONS**

Installation
Instructions

47

**CBC-LOK® TUBING
SELECTION &
PREPARATION**

Tubing
Selection &
Preparation

48

**GAS SERVICE/
SAFETY/
QUALITY**

Gas Service/
Safety/
Quality

49

**TECHNICAL
DATA**

Technical
Data

50

**TRACEABILITY/
MATERIAL SPEC./
PRE-SET TOOL**

Heat
Traceability/
Mat'l Spec./
Pre-Set Tool

51

**TUBE INSERTION
CHART/
APPLICATIONS**

Tube Insertion
Chart/
Applications

52

How to Order CBC-LOK® Tube Fittings

CBC-Lok® Tube Fittings are ordered as listed in this catalog by inserting the material code before the part number. CBC-Lok® Tube Fittings can be identified through the part number as to material, tube size, configuration and thread connection. The part number describes a complete fitting assembly. The size nomenclature to describe a tee fitting is from left (1) to right (2) and down (3). **Special Configurations available upon request.**

Example: A Stainless Steel Female Run Tee, 3/8" Tube Size to 1/4" Female Pipe to 3/8" Tube is designated as follows.

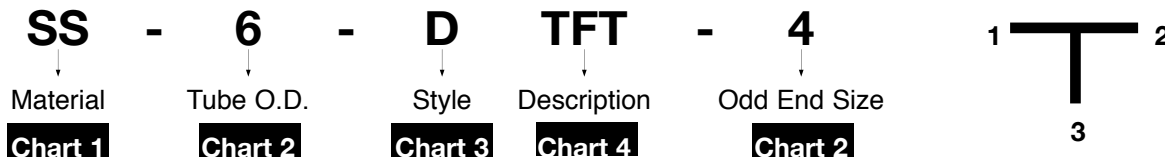

Chart 1 - Material

B	Brass
SS	Stainless Steel
S	Steel

Chart 3 - Style

D	CBC-Lok®
---	----------

Chart 2 - Tube O.D./Odd End Size

Designator	Tube or Hose OD (inches)	Pipe Thread (NPT)	AN Tube Flare Size (inches)	Pipe Thread BSPP/BSPT
1	1/16	1/16-27		1/16-28
2	1/8	1/8-27	1/8	1/8-28
3	3/16		3/16	
4	1/4	1/4-18	1/4	1/4-19
5	5/16		5/16	
6	3/8	3/8-18	3/8	3/8-19
8	1/2	1/2-14	1/2	1/2-14
10	5/8		5/8	
12	3/4	3/4-14	3/4	3/4-14
14	7/8		7/8	
16	1	1.0-11 1/2	1	1.0-11

Chart 4 - Description

DATANF	Adapter Tube to AN Flare
DATPF	Adapter Tube to Female Pipe
DATPM	Adapter Tube to Male Pipe
DBHA	Bulkhead Adapter
DBHFP	Bulkhead Female Pipe Connector
DBHMP	Bulkhead Male Pipe Connector
DBHU	Bulkhead Union
DBUANF	Bulkhead to AN Flare Union
DCAP	Cap
DF PLUG	Fitting Plug
DFC	Female Connector
DMC	Male Connector
DMC-ORS	O Ring Straight Thread Male Connector
DMC-ORT	O Ring Pipe Thread Male Connector
DMC-STB	Straight Thread Boss Male Connector
DPCU	Port Connector Union
DRATT	Reducer Adapter Tube to Tube
DRPC	Reducing Port Connector
DRU	Reducing Union
DTBW	Tube to Butt Weld Connector
DTSW	Tube to Socket Weld Connector
DU	Union

DUANF	Tube to AN Flare Union
DELU	Union Elbow
DELU45	Union 45° Elbow
DFE	Female Elbow
DME45	Male 45° Elbow
DME	Male Elbow
DTBWE	Tube to Butt Weld Elbow
DTSWE	Tube to Socket Weld Elbow
DTFT	Female Run Tee
DTMT	Male Run Tee
DTTF	Female Branch Tee
DTTM	Male Branch Tee
DTTT	Union Tee
DCR	Union Cross
DBI	Barbed Insert
DPI	Plane Insert
DN	Nut
DKN	Knurled Nut
DFC	Front Collet
DRC	Rear Collet
1MDF	Mud Dauber Fitting

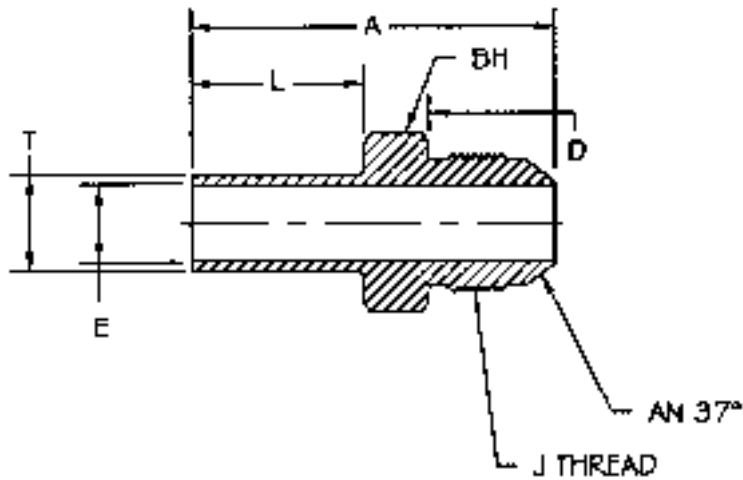

Adapter Tube to AN Flare

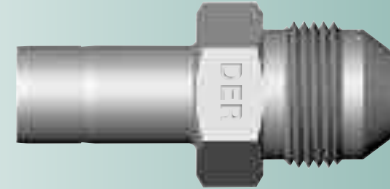

PART NUMBER	INTERCHANGES WITH	T TUBE O.D.	J THREAD	A	D	E THRU HOLE	L	BH BODY HEX
2-DATANF-2	2-TA-1-2AN	1/8	5/16-24	1.203	.448	.062	.531	3/8
2-DATANF-4	2-TA-1-4AN	1/8	7/16-20	1.312	.550	.094	.531	1/2
3-DATANF-3	3-TA-1-3AN	3/16	3/8-24	1.250	.479	.125	.562	7/16
4-DATANF-4	4-TA-1-4AN	1/4	7/16-20	1.469	.550	.172	.625	1/2
5-DATANF-5	5-TA-1-5AN	5/16	1/2-20	1.453	.550	.234	.656	9/16
6-DATANF-4	6-TA-1-4AN	3/8	7/16-20	1.531	.550	.172	.687	1/2
6-DATANF-6	6-TA-1-6AN	3/8	9/16-18	1.500	.556	.281	.687	5/8
8-DATANF-8	8-TA-1-8AN	1/2	3/4-16	1.906	.657	.391	.906	13/16
10-DATANF-10	10-TA-1-10AN	5/8	7/8-14	2.031	.758	.484	.969	15/16
12-DATANF-12	12-TA-1-12AN	3/4	1-1/16-12	2.187	.864	.656	.969	1-1/8
16-DATANF-16	16-TA-1-16AN	1	1-5/16-12	2.531	.911	.937	1.219	1-3/8

Adapter Tube to Female Pipe

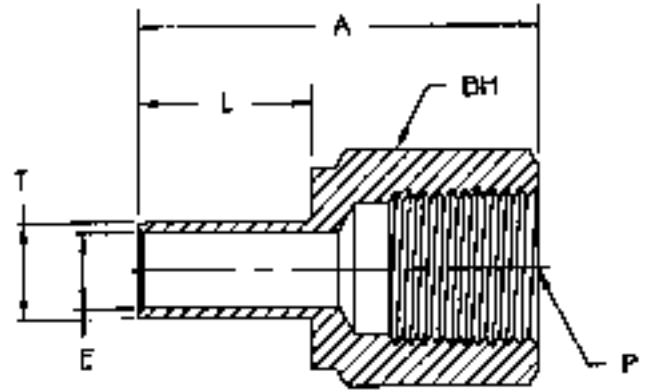

PART NUMBER	INTERCHANGES WITH	T TUBE O.D.	P PIPE END NPT	A	E THRU HOLE	L	BH BODY HEX
2-DATPF-2	2-TA-7-2 2FA2N	1/8	1/8	1.234	.094	.531	9/16
2-DATPF-4	2-TA-7-4 2FA4N	1/8	1/4	1.375	.094	.531	3/4
3-DATPF-2	3-TA-7-2 3FA2N	3/16	1/8	1.266	.125	.562	9/16
3-DATPF-4	3-TA-7-4 3FA4N	3/16	1/4	1.406	.125	.562	3/4
4-DATPF-2	4-TA-7-2 4FA2N	1/4	1/8	1.312	.187	.625	9/16
4-DATPF-4	4-TA-7-4 4FA4N	1/4	1/4	1.469	.187	.625	3/4
4-DATPF-6	4-TA-7-6 4FA6N	1/4	3/8	1.562	.187	.625	7/8
4-DATPF-8	4-TA-7-8 4FA8N	1/4	1/2	1.812	.187	.625	1-1/16
5-DATPF-2	5-TA-7-2 5FA2N	5/16	1/8	1.359	.250	.656	9/16
5-DATPF-4	5-TA-7-4 5FA4N	5/16	1/4	1.516	.250	.656	3/4
6-DATPF-2	6-TA-7-2 6FA2N	3/8	1/8	1.391	.281	.687	9/16
6-DATPF-4	6-TA-7-4 6FA4N	3/8	1/4	1.547	.281	.687	3/4
6-DATPF-6	6-TA-7-6 6FA6N	3/8	3/8	1.625	.281	.687	7/8
6-DATPF-8	6-TA-7-8 6FA8N	3/8	1/2	1.843	.281	.687	1-1/16
8-DATPF-4	8-TA-7-4 8FA4N	1/2	1/4	1.719	.391	.906	3/4
8-DATPF-6	8-TA-7-6 8FA6N	1/2	3/8	1.859	.391	.906	7/8
8-DATPF-8	8-TA-7-8 8FA8N	1/2	1/2	2.093	.391	.906	1-1/16
10-DATPF-6	10-TA-7-6 10FA6N	5/8	3/8	1.828	.500	.969	7/8
10-DATPF-8	10-TA-7-8 10FA8N	5/8	1/2	2.093	.500	.969	1-1/16
12-DATPF-8	12-TA-7-8 12FA8N	3/4	1/2	2.093	.594	.969	1-1/16
14-DATPF-12	14-TA-7-12 14FA12N	7/8	3/4	2.203	.687	1.031	1-5/16
16-DATPF-12	16-TA-7-12 16FA12N	1	3/4	2.406	.797	1.219	1-5/16
16-DATPF-16	16-TA-7-16 16FA16N	1	1	2.547	.797	1.219	1-5/8

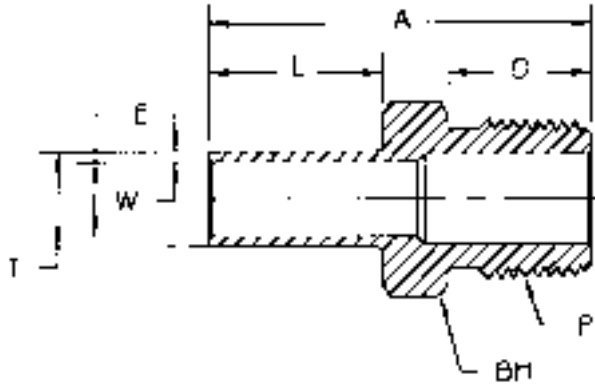

Adapter Tube to Male Pipe

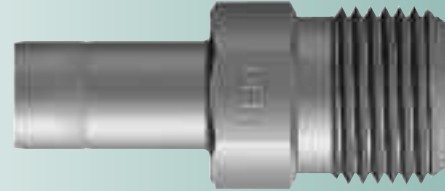

PART NUMBER	INTERCHANGES WITH	T TUBE O.D.	P PIPE END NPT	A	D	E ¹ THRU HOLE	L	W	BH BODY HEX
2-DATPM-2	2-TA-1-2 2MA2N	1/8	1/8	1.156	.375	.093	.531	.022	7/16
2-DATPM-4	2-TA-1-4 2MA4N	1/8	1/4	1.375	.562	.093	.531	.022	9/16
3-DATPM-2	3-TA-1-2 3MA2N	3/16	1/8	1.187	.375	.187	.562	.022	7/16
3-DATPM-4	3-TA-1-4 3MA4N	3/16	1/4	1.406	.562	.281	.562	.022	9/16
4-DATPM-2	4-TA-1-2 4MA2N	1/4	1/8	1.250	.375	.171	.625	.032	7/16
4-DATPM-4	4-TA-1-4 4MA4N	1/4	1/4	1.469	.562	.171	.625	.032	9/16
4-DATPM-6	4-TA-1-6 4MA6N	1/4	3/8	1.500	.562	.171	.625	.032	11/16
4-DATPM-8	4-TA-1-8 4MA8N	1/4	1/2	1.718	.750	.171	.625	.032	7/8
5-DATPM-2	5-TA-1-2 5MA2N	5/16	1/8	1.297	.375	.187	.656	.032	7/16
5-DATPM-4	5-TA-1-4 5MA4N	5/16	1/4	1.500	.562	.250	.656	.032	9/16
6-DATPM-2	6-TA-1-2 6MA2N	3/8	1/8	1.343	.375	.187	.687	.032	7/16
6-DATPM-4	6-TA-1-4 6MA4N	3/8	1/4	1.547	.562	.281	.687	.032	9/16
6-DATPM-6	6-TA-1-6 6MA6N	3/8	3/8	1.562	.562	.281	.687	.032	11/16
6-DATPM-8	6-TA-1-8 6MA8N	3/8	1/2	1.781	.750	.281	.687	.032	7/8
8-DATPM-4	8-TA-1-4 8MA4N	1/2	1/4	1.750	.562	.281	.906	.047	9/16
8-DATPM-6	8-TA-1-6 8MA6N	1/2	3/8	1.781	.562	.375	.906	.047	11/16
8-DATPM-8	8-TA-1-8 8MA8N	1/2	1/2	2.000	.750	.391	.906	.047	7/8
10-DATPM-6	10-TA-1-6 10MA6N	5/8	3/8	1.844	.562	.375	.969	.047	11/16
10-DATPM-8	10-TA-1-8 10MA8N	5/8	1/2	2.062	.750	.468	.969	.047	7/8
10-DATPM-12	10-TA-1-12 10MA12N	5/8	3/4	2.062	.750	.500	.969	.047	1-1/16
12-DATPM-8	12-TA-1-8 12MA8N	3/4	1/2	2.062	.750	.468	.969	.047	7/8
12-DATPM-12	12-TA-1-12 12MA12N	3/4	3/4	2.062	.750	.594	.969	.047	1-1/16
12-DATPM-16	12-TA-1-16 12MA16N	3/4	1	2.359	.937	.594	.969	.047	1-3/8
14-DATPM-12	14-TA-1-12 14MA12N	7/8	3/4	2.125	.750	.687	1.031	.047	1-3/8
16-DATPM-12	16-TA-1-12 16MA12N	1	3/4	2.312	.750	.625	1.218	.047	1-1/16
16-DATPM-16	16-TA-1-16 16MA16N	1	1	2.625	.937	.797	1.218	.047	1-3/8

¹ The E dimension is the minimum opening. These fittings may have a larger opening at the pipe/straight thread end.

Bulkhead Adapter

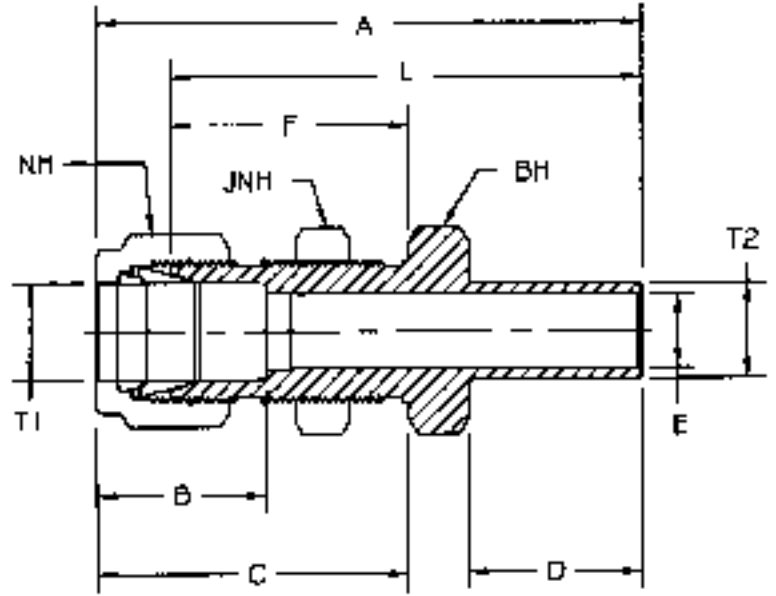
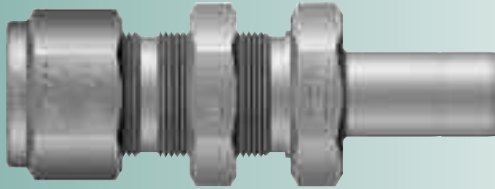

PART NUMBER	INTERCHANGES WITH	T1 TUBE O.D.	T2 TUBE O.D.	A	B	C	D	E THRU HOLE	F	L	NH NUT HEX	JNH JAM NUT HEX	BH BODY HEX	PANEL HOLE
2-DBHA-2	200-R1-2 2TUBC2	1/8	1/8	1.953	.500	1.234	.531	.078	.969	1.687	7/16	1/2	1/2	21/64
4-DBHA-4	400-R1-4 4TUBC4	1/4	1/4	2.203	.609	1.328	.625	.187	1.031	1.906	9/16	5/8	5/8	29/64
6-DBHA-6	600-R1-6 6TUBC6	3/8	3/8	2.406	.656	1.453	.687	.281	1.156	2.125	11/16	3/4	3/4	37/64
8-DBHA-8	810-R1-8 8TUBC8	1/2	1/2	2.875	.906	1.656	.906	.391	1.250	2.468	7/8	15/16	15/16	49/64

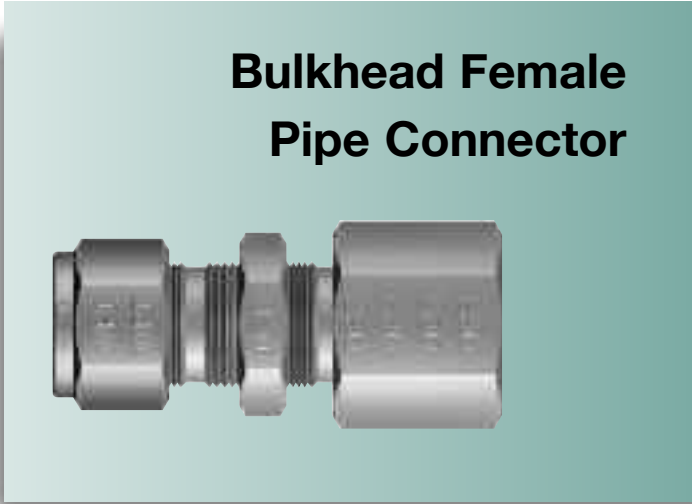
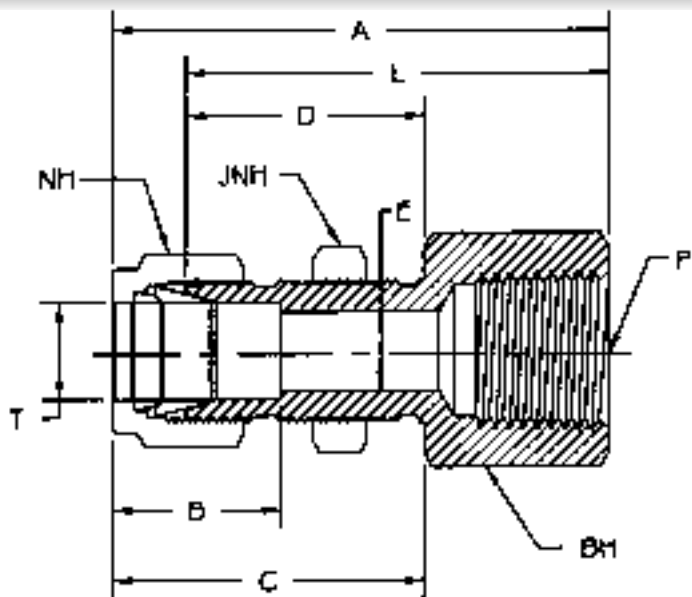

PART NUMBER	INTERCHANGES WITH	T TUBE O.D.	P PIPE END NPT	A	B	C	D	E THRU HOLE	L	NH NUT HEX	JNH JAM NUT HEX	BH BODY HEX	PANEL HOLE
2-DBHFP-2	200-71-2 2FBC2N	1/8	1/8	1.766	.500	1.234	.969	.094	1.500	7/16	1/2	9/16	21/64
3-DBHFP-2	300-71-2 3FBC2N	3/16	1/8	1.797	.547	1.266	1.000	.125	1.531	1/2	9/16	9/16	25/64
4-DBHFP-2	400-71-2 4FBC2N	1/4	1/8	1.859	.609	1.328	1.031	.187	1.562	9/16	5/8	5/8	29/64
4-DBHFP-4	400-71-4 4FBC4N	1/4	1/4	2.047	.609	1.328	1.031	.187	1.750	9/16	5/8	3/4	29/64
5-DBHFP-2	500-71-2 5FBC2N	5/16	1/8	1.969	.641	1.422	1.125	.250	1.656	5/8	3/4	11/16	33/64
6-DBHFP-4	600-71-4 6FBC4N	3/8	1/4	2.172	.656	1.453	1.156	.281	1.875	11/16	3/4	3/4	37/64
8-DBHFP-6	810-71-6 8FBC6N	1/2	3/8	2.437	.906	1.656	1.250	.406	2.031	7/8	15/16	15/16	49/64
8-DBHFP-8	810-71-8 8FBC8N	1/2	1/2	2.625	.906	1.656	1.250	.406	2.219	7/8	15/16	1-1/16	49/64
10-DBHFP-8	1010-71-8 10FBC8N	5/8	1/2	2.656	.969	1.687	1.281	.500	2.250	1	1-1/16	1-1/16	57/64
16-DBHFP-16	1610-71-16 16FBC16N	1	1	3.687	1.234	2.266	1.781	.875	3.187	1-1/2	1-1/2	1-5/8	1-21/64

Bulkhead Male Pipe Connector

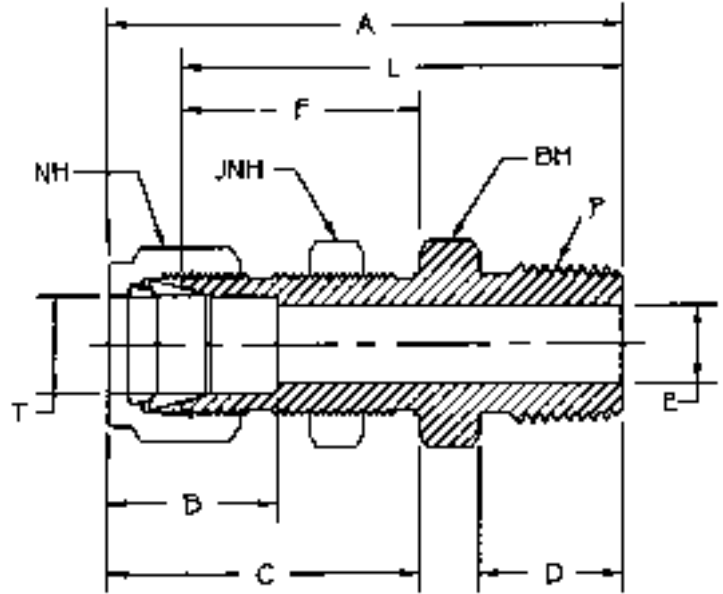
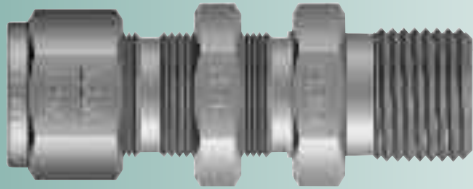

PART NUMBER	INTERCHANGES WITH	T TUBE O.D.	P PIPE END NPT	A	B	C	D	E ¹ THRU HOLE	F	L	NH NUT HEX	JNH JAM NUT HEX	BH BODY HEX	PANEL HOLE
1-DBHMP-1	100-11-1 1MBC1N	1/16	1/16	1.187	.437	.687	.375	.052	.531	1.031	5/16	7/16	5/16	13/64
1-DBHMP-2	100-11-2 1MBC2N	1/16	1/8	1.234	.437	.687	.375	.052	.531	1.094	5/16	7/16	7/16	13/64
2-DBHMP-2	200-11-2 2MBC2N	1/8	1/8	1.828	.500	1.234	.375	.094	.969	1.578	7/16	1/2	1/2	21/64
3-DBHMP-2	300-11-2 3MBC2N	3/16	1/8	1.859	.547	1.266	.375	.125	1.000	1.594	1/2	9/16	9/16	25/64
4-DBHMP-2	400-11-2 4MBC2N	1/4	1/8	1.953	.609	1.328	.375	.187	1.031	1.656	9/16	5/8	5/8	29/64
4-DBHMP-4	400-11-4 4MBC4N	1/4	1/4	2.109	.609	1.328	.562	.187	1.031	1.843	9/16	5/8	5/8	29/64
4-DBHMP-6	400-11-6 4MBC6N	1/4	3/8	2.187	.609	1.328	.562	.187	1.016	1.891	9/16	5/8	11/16	29/64
4-DBHMP-8	400-11-8 4MBC8N	1/4	1/2	2.484	.609	1.328	.562	.187	1.016	2.187	9/16	5/8	7/8	29/64
6-DBHMP-4	600-11-4 6MBC4N	3/8	1/4	2.266	.656	1.453	.562	.281	1.156	1.969	11/16	3/4	3/4	37/64
6-DBHMP-6	600-11-6 6MBC6N	3/8	3/8	2.312	.656	1.437	.562	.281	1.156	1.969	11/16	3/4	3/4	37/64
6-DBHMP-8	600-11-8 6MBC8N	3/8	1/2	2.609	.656	1.437	.750	.375	1.156	2.312	11/16	3/4	7/8	37/64
8-DBHMP-4	810-11-4 8MBC4N	1/2	1/4	2.547	.906	1.656	.562	.375	1.250	2.141	7/8	15/16	15/16	49/64
8-DBHMP-6	810-11-6 8MBC6N	1/2	3/8	2.484	.906	1.656	.562	.375	1.250	2.094	7/8	15/16	15/16	49/64
8-DBHMP-8	810-11-8 8MBC8N	1/2	1/2	2.719	.906	1.656	.750	.406	1.250	2.312	7/8	15/16	15/16	49/64

¹ The E dimension is the minimum opening. These fittings may have a larger opening at the pipe/straight thread end.

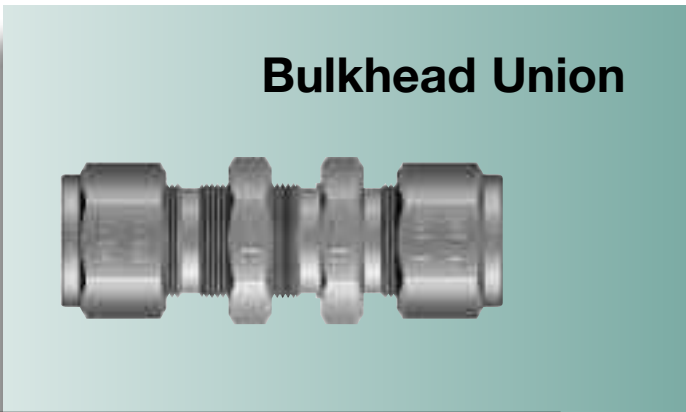
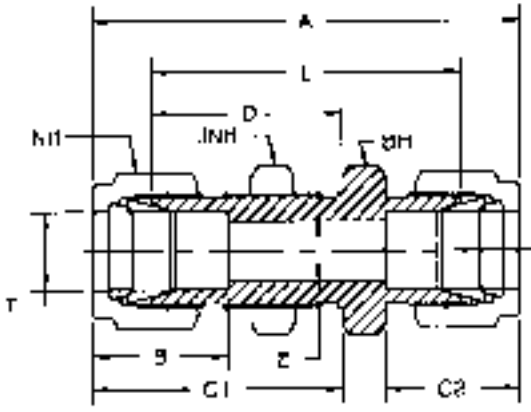

PART NUMBER	INTERCHANGES WITH	T TUBE O.D.	A	B	C1	C2	D	E THRU HOLE	L	NH NUT HEX	JNH JAM NUT HEX	BH BODY HEX	PANEL HOLE
1-DBHU-1	100-61 1BC1	1/16	1.234	.344	.687	.437	.531	.052	.937	5/16	5/16	5/16	13/64
2-DBHU-2	200-61 2BC2	1/8	2.016	.500	1.234	.609	.969	.094	1.500	7/16	1/2	1/2	21/64
3-DBHU-3	300-61 3BC3	3/16	2.109	.547	1.266	.625	1.000	.125	1.594	1/2	9/16	9/16	25/64
4-DBHU-4	400-61 4BC4	1/4	2.266	.609	1.328	.703	1.031	.187	1.687	9/16	5/8	5/8	29/64
5-DBHU-5	500-61 5BC5	5/16	2.391	.641	1.406	.734	1.125	.250	1.812	5/8	11/16	11/16	33/64
6-DBHU-6	600-61 6BC6	3/8	2.453	.656	1.453	.766	1.156	.281	1.875	11/16	3/4	3/4	37/64
8-DBHU-8	810-61 8BC8	1/2	2.797	.906	1.656	.859	1.250	.406	2.000	7/8	15/16	15/16	49/64
10-DBHU-10	1010-61 10BC10	5/8	2.859	.969	1.687	.859	1.281	.500	2.062	1	1-1/16	1-1/16	57/64
12-DBHU-12	1210-61 12BC12	3/4	3.109	.969	1.875	.859	1.469	.625	2.312	1-1/8	1-3/16	1-3/16	1-1/64
14-DBHU-14	1410-61 14BC14	7/8	3.328	1.031	2.094	.875	1.687	.718	2.531	1-1/4	1-3/8	1-3/8	1-9/64
16-DBHU-16	1610-61 16BC16	1	3.766	1.234	2.266	1.047	1.781	.875	2.812	1-1/2	1-5/8	1-5/8	1-21/64

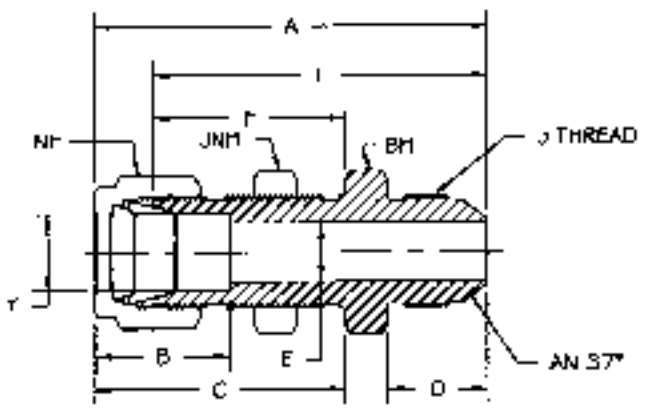

PART NUMBER	INTERCHANGES WITH	T TUBE O.D.	J THREAD	A	B	C	D	E THRU HOLE	F	L	NH NUT HEX	BH BODY HEX	JNH JAM NUT HEX	PANEL HOLE
2-DBUANF-2	200-61-2AN 2XABC2	1/8	5/16-24	1.906	.516	1.234	.453	.062	.969	1.656	7/16	1/2	1/2	21/64
3-DBUANF-3	300-61-3AN 3XABC3	3/16	3/8-24	1.984	.547	1.266	.484	.125	1.000	1.719	1/2	9/16	9/16	25/64
4-DBUANF-4	400-61-4AN 4XABC4	1/4	7/16-20	2.125	.609	1.328	.547	.172	1.031	1.828	9/16	5/8	5/8	29/64
5-DBUANF-5	500-61-5AN 5XABC5	5/16	1/2-20	2.219	.641	1.406	.547	.234	1.125	1.922	5/8	11/16	11/16	33/64
6-DBUANF-6	600-61-6AN 6XABC6	3/8	9/16-18	2.250	.656	1.453	.562	.281	1.156	1.969	11/16	11/16	3/4	37/64
8-DBUANF-8	810-61-8AN 8XABC8	1/2	3/4-16	2.594	.906	1.656	.656	.391	1.250	2.187	7/8	15/16	15/16	49/64
10-DBUANF-10	1010-61-10AN 10XABC10	5/8	7/8-14	2.734	.969	1.687	.766	.484	1.281	2.234	1	1-1/16	1-1/16	57/64
12-DBUANF-12	1210-61-12AN 12XABC12	3/4	1-1/16-12	3.109	.969	1.875	.859	.609	1.469	2.719	1-1/8	1-3/16	1-3/16	1-1/64
16-DBUANF-16	1610-61-16AN 16XABC16	1	1-5/16-12	3.641	1.234	2.266	.906	.844	1.781	3.156	1-1/2	1-5/8	1-5/8	1-21/64

DCAP/DF Plug

Cap

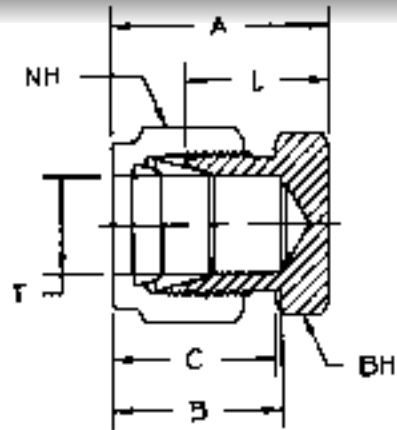
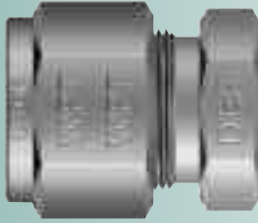

PART NUMBER	INTERCHANGES WITH		T TUBE O.D.	A	B	C	L	BH BODY HEX	NH NUT HEX
1-DCAP	100-C	1BLEN1	1/16	.594	.344	.437	.437	5/16	5/16
2-DCAP	200-C	2BLEN2	1/8	.797	.500	.609	.531	7/16	7/16
3-DCAP	300-C	3BLEN3	3/16	.844	.547	.625	.578	7/16	1/2
4-DCAP	400-C	4BLEN4	1/4	.922	.609	.703	.625	1/2	9/16
5-DCAP	500-C	5BLEN5	5/16	.969	.641	.734	.672	9/16	5/8
6-DCAP	600-C	6BLEN6	3/8	1.016	.656	.766	.719	5/8	11/16
8-DCAP	810-C	8BLEN8	1/2	1.156	.906	.859	.750	13/16	7/8
10-DCAP	1010-C	10BLEN10	5/8	1.188	.969	.859	.781	15/16	1
12-DCAP	1210-C	12BLEN12	3/4	1.234	.969	.859	.844	1-1/16	1-1/8
14-DCAP	1410-C	14BLEN14	7/8	1.344	1.016	.859	.937	1-3/16	1-1/4
16-DCAP	1610-C	16BLEN16	1	1.516	1.234	1.047	1.031	1-3/8	1-1/2

Fitting Plug

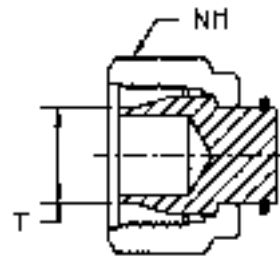

PART NUMBER	INTERCHANGES WITH		T TUBE O.D.	NH NUT HEX
1-DF PLUG	100-P	1BLP1	1/16	5/16
2-DF PLUG	200-P	2BLP2	1/8	7/16
3-DF PLUG	300-P	3BLP3	3/16	1/2
4-DF PLUG	400-P	4BLP4	1/4	9/16
5-DF PLUG	500-P	5BLP5	5/16	5/8
6-DF PLUG	600-P	6BLP6	3/8	11/16
8-DF PLUG	810-P	8BLP8	1/2	7/8
10-DF PLUG	1010-P	10BLP10	5/8	1
12-DF PLUG	1210-P	12BLP12	3/4	1-1/8
14-DF PLUG	1410-P	14BLP14	7/8	1-1/4
16-DF PLUG	1610-P	16BLP16	1	1-1/2

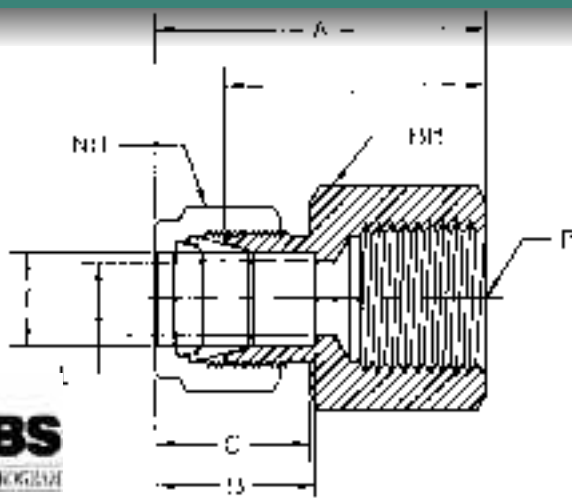

Female Connector



PART NUMBER	INTERCHANGES WITH	T TUBE O.D.	P PIPE END NPT	A	B	C	E THRU HOLE	L	NH NUT HEX	BH BODY HEX	
1-DFC-1	100-7-1	1FSC1N	1/16	1/16	.937	.344	.437	.052	.782	5/16	7/16
1-DFC-2	100-7-2	1FSC2N	1/16	1/8	.969	.344	.437	.052	.812	5/16	9/16
2-DFC-2	200-7-2	2FSC2N	1/8	1/8	1.125	.500	.609	.094	.875	7/16	9/16
2-DFC-4	200-7-4	2FSC4N	1/8	1/4	1.328	.500	.609	.094	1.062	7/16	3/4
2-DFC-6	200-7-6	2FSC6N	1/8	3/8	1.390	.500	.609	.094	1.125	7/16	7/8
3-DFC-2	300-7-2	3FSC2N	3/16	1/8	1.171	.547	.625	.125	.906	1/2	9/16
3-DFC-4	300-7-4	3FSC4N	3/16	1/4	1.344	.547	.625	.125	1.094	1/2	3/4
3-DFC-8	300-7-8	3FSC8N	3/16	1/2	1.594	.547	.625	.125	1.344	1/2	1-1/8
4-DFC-1	400-7-1	4FSC1N	1/4	1/16	1.203	.609	.703	.187	.906	9/16	1/2
4-DFC-2	400-7-2	4FSC2N	1/4	1/8	1.234	.609	.703	.187	.937	9/16	9/16
4-DFC-4	400-7-4	4FSC4N	1/4	1/4	1.406	.609	.703	.187	1.125	9/16	3/4
4-DFC-6	400-7-6	4FSC6N	1/4	3/8	1.484	.609	.703	.187	1.187	9/16	7/8
4-DFC-8	400-7-8	4FSC8N	1/4	1/2	1.670	.609	.703	.187	1.375	9/16	1-1/16
5-DFC-2	500-7-2	5FSC2N	5/16	1/8	1.266	.640	.734	.250	.969	5/8	9/16
5-DFC-4	500-7-4	5FSC4N	5/16	1/4	1.453	.640	.734	.250	1.156	5/8	3/4
5-DFC-6	500-7-6	5FSC6N	5/16	3/8	1.515	.640	.734	.250	1.218	5/8	7/8
5-DFC-8	500-7-8	5FSC8N	5/16	1/2	1.703	.640	.734	.250	1.406	5/8	1-1/16
6-DFC-2	600-7-2	6FSC2N	3/8	1/8	1.297	.656	.766	.281	1.000	11/16	5/8
6-DFC-4	600-7-4	6FSC4N	3/8	1/4	1.484	.656	.766	.281	1.187	11/16	3/4
6-DFC-6	600-7-6	6FSC6N	3/8	3/8	1.547	.656	.766	.281	1.250	11/16	7/8
6-DFC-8	600-7-8	6FSC8N	3/8	1/2	1.734	.656	.766	.281	1.437	11/16	1-1/16
6-DFC-12	600-7-12	6FSC12N	3/8	3/4	1.875	.656	.766	.281	1.593	11/16	1-5/16
8-DFC-4	810-7-4	8FSC4N	1/2	1/4	1.593	.906	.859	.406	1.187	7/8	13/16
8-DFC-6	810-7-6	8FSC6N	1/2	3/8	1.656	.906	.859	.406	1.250	7/8	7/8
8-DFC-8	810-7-8	8FSC8N	1/2	1/2	1.843	.906	.859	.406	1.437	7/8	1-1/16
8-DFC-12	810-7-12	8FSC12N	1/2	3/4	1.906	.906	.859	.406	1.500	7/8	1-5/16
8-DFC-16	810-7-16	8FSC16N	1/2	1	2.265	.906	.859	.406	1.875	7/8	1-5/8
10-DFC-4	1010-7-4	10FSC4N	5/8	1/4	1.797	.969	.859	.281	1.406	1	15/16
10-DFC-6	1010-7-6	10FSC6N	5/8	3/8	1.656	.969	.859	.500	1.250	1	15/16
10-DFC-8	1010-7-8	10FSC8N	5/8	1/2	1.844	.969	.859	.500	1.437	1	1-1/16
10-DFC-12	1010-7-12	10FSC12N	5/8	3/4	1.953	.969	.859	.500	1.562	1	1-5/16
12-DFC-6	1210-7-6	12FSC6N	3/4	3/8	1.655	.969	.859	.500	1.265	1-1/8	1-1/16
12-DFC-8	1210-7-8	12FSC8N	3/4	1/2	1.844	.969	.859	.625	1.437	1-1/8	1-1/16
12-DFC-12	1210-7-12	12FSC12N	3/4	3/4	1.906	.969	.859	.625	1.500	1-1/8	1-5/16
12-DFC-16	1210-7-16	12FSC16N	3/4	1	2.265	.969	.859	.625	1.875	1-1/8	1-5/8
14-DFC-8	1410-7-8	14FSC8N	7/8	1/2	1.828	1.016	.859	.687	1.437	1-1/4	1-5/16
14-DFC-12	1410-7-12	14FSC12N	7/8	3/4	1.969	1.016	.859	.719	1.562	1-1/4	1-3/8
14-DFC-16	1410-7-16	14FSC16N	7/8	1	2.234	1.016	.859	.719	1.843	1-1/4	1-5/8
16-DFC-12	1610-7-12	16FSC12N	1	3/4	2.109	1.234	1.047	.875	1.625	1-1/2	1-3/8
16-DFC-16	1610-7-16	16FSC16N	1	1	2.453	1.234	1.047	.875	1.969	1-1/2	1-5/8

NOTE: All dimensions subject to change, to be used for reference only.

Male Connector

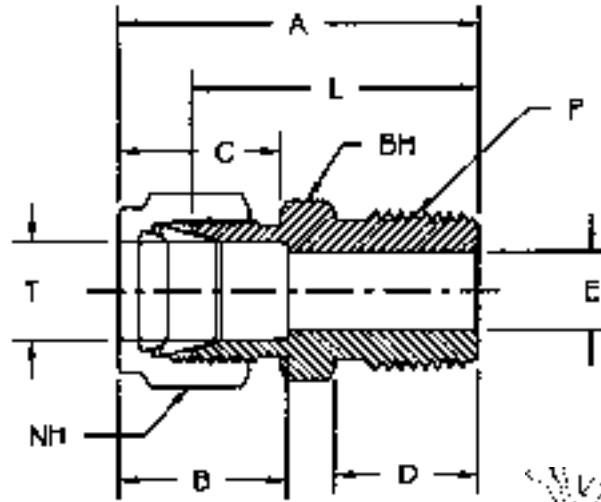
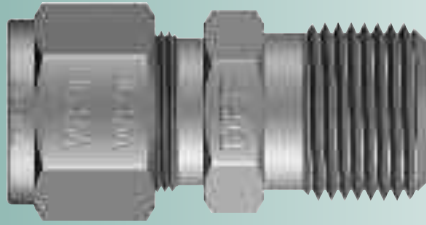

PART NUMBER	INTERCHANGES WITH	T TUBE O.D.	P PIPE END NPT	A	B	C	D	E ¹ THRU HOLE	L	NH NUT HEX	BH BODY HEX	
1-DMC-1	100-1-1	1MSC1N	1/16	1/16	.937	.344	.437	.375	.052	.797	5/16	5/16
1-DMC-2	100-1-2	1MSC2N	1/16	1/8	1.031	.344	.437	.375	.052	.875	5/16	7/16
2-DMC-1	200-1-1	2MSC1N	1/8	1/16	1.172	.500	.609	.375	.094	.906	7/16	7/16
2-DMC-2	200-1-2	2MSC2N	1/8	1/8	1.203	.500	.609	.375	.094	.937	7/16	7/16
2-DMC-4	200-1-4	2MSC4N	1/8	1/4	1.406	.500	.609	.562	.094	1.140	7/16	9/16
2-DMC-6	200-1-6	2MSC6N	1/8	3/8	1.406	.500	.609	.562	.094	1.156	7/16	11/16
2-DMC-8	200-1-8	2MSC8N	1/8	1/2	1.656	.500	.609	.750	.094	1.406	7/16	7/8
3-DMC-2	300-1-2	3MSC2N	3/16	1/8	1.234	.546	.625	.375	.125	.969	1/2	7/16
3-DMC-4	300-1-4	3MSC4N	3/16	1/4	1.437	.546	.625	.562	.125	1.171	1/2	9/16
4-DMC-1	400-1-1	4MSC1N	1/4	1/16	1.299	.609	.703	.375	.125	1.000	9/16	1/2
4-DMC-2	400-1-2	4MSC2N	1/4	1/8	1.299	.609	.703	.375	.187	1.000	9/16	1/2
4-DMC-4	400-1-4	4MSC4N	1/4	1/4	1.484	.609	.703	.562	.187	1.203	9/16	9/16
4-DMC-6	400-1-6	4MSC6N	1/4	3/8	1.516	.609	.703	.562	.187	1.219	9/16	11/16
4-DMC-8	400-1-8	4MSC8N	1/4	1/2	1.766	.609	.703	.750	.187	1.469	9/16	7/8
4-DMC-12	400-1-12	4MSC12N	1/4	3/4	1.828	.609	.703	.750	.187	1.531	9/16	1-1/16
4-DMC-16	400-1-16	4MSC16N	1/4	1	2.109	.609	.703	.937	.187	1.812	9/16	1-3/8
5-DMC-2	500-1-2	5MSC2N	5/16	1/8	1.343	.641	.734	.375	.187	1.047	5/8	9/16
5-DMC-4	500-1-4	5MSC4N	5/16	1/4	1.516	.641	.734	.562	.250	1.234	5/8	9/16
5-DMC-6	500-1-6	5MSC6N	5/16	3/8	1.547	.641	.734	.562	.250	1.250	5/8	11/16
5-DMC-8	500-1-8	5MSC8N	5/16	1/2	1.765	.641	.734	.750	.250	1.468	5/8	7/8
6-DMC-2	600-1-2	6MSC2N	3/8	1/8	1.390	.656	.766	.375	.187	1.109	11/16	5/8
6-DMC-4	600-1-4	6MSC4N	3/8	1/4	1.578	.656	.766	.562	.281	1.281	11/16	5/8
6-DMC-6	600-1-6	6MSC6N	3/8	3/8	1.578	.656	.766	.562	.281	1.281	11/16	11/16
6-DMC-8	600-1-8	6MSC8N	3/8	1/2	1.828	.656	.766	.750	.281	1.531	11/16	7/8
6-DMC-12	600-1-12	6MSC12N	3/8	3/4	1.875	.656	.766	.750	.281	1.593	11/16	1-1/16
6-DMC-16	600-1-16	6MSC16N	3/8	1	2.141	.656	.766	.937	.281	1.843	11/16	1-3/8

NOTE: All dimensions subject to change, to be used for reference only.

¹ The E dimension is the minimum opening. These fittings may have a larger opening at the pipe/straight thread end.

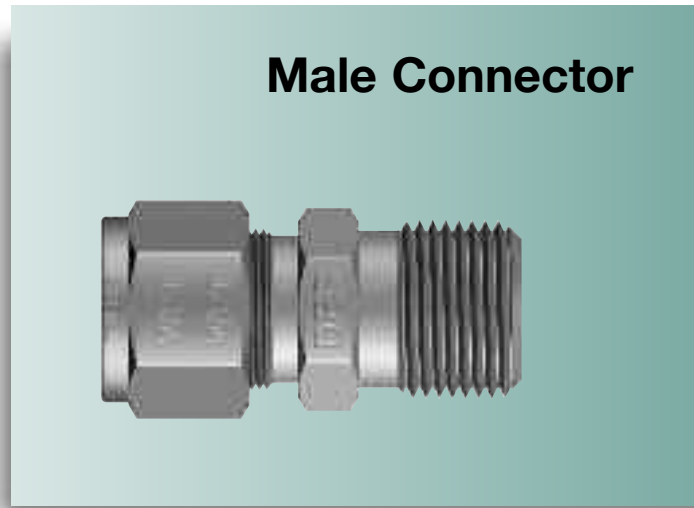
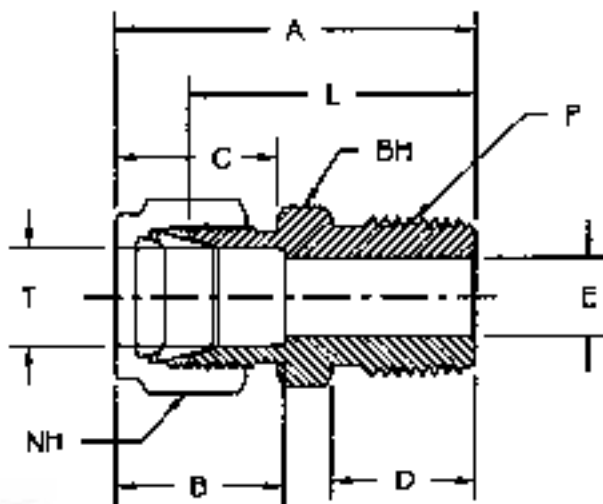

Male Connector



PART NUMBER	INTERCHANGES WITH	T TUBE O.D.	P PIPE END NPT	A	B	C	D	E ¹ THRU HOLE	L	NH NUT HEX	BH BODY HEX	
8-DMC-2	810-1-2	8MSC2N	1/2	1/8	1.531	.906	.859	.375	.187	1.125	7/8	13/16
8-DMC-4	810-1-4	8MSC4N	1/2	1/4	1.719	.906	.859	.562	.281	1.312	7/8	13/16
8-DMC-6	810-1-6	8MSC6N	1/2	3/8	1.719	.906	.859	.562	.375	1.312	7/8	13/16
8-DMC-8	810-1-8	8MSC8N	1/2	1/2	1.937	.906	.859	.750	.406	1.531	7/8	7/8
8-DMC-12	810-1-12	8MSC12N	1/2	3/4	1.984	.906	.859	.750	.406	1.593	7/8	1-1/16
8-DMC-16	810-1-16	8MSC16N	1/2	1	2.250	.906	.859	.937	.406	1.859	7/8	1-3/8
10-DMC-4	1010-1-4	10MSC4N	5/8	1/4	1.934	.969	.859	.562	.281	1.343	1	15/16
10-DMC-6	1010-1-6	10MSC6N	5/8	3/8	1.934	.969	.859	.562	.375	1.343	1	15/16
10-DMC-8	1010-1-8	10MSC8N	5/8	1/2	1.937	.969	.859	.750	.469	1.531	1	15/16
10-DMC-12	1010-1-12	10MSC12N	5/8	3/4	1.984	.969	.859	.750	.500	1.593	1	1-1/16
10-DMC-16	1010-1-16	10MSC16N	5/8	1	2.172	.969	.859	.937	.500	1.781	1	1-3/8
12-DMC-4	1210-1-4	12MSC4N	3/4	1/4	1.796	.969	.859	.562	.281	1.405	1-1/8	1-1/8
12-DMC-6	1210-1-6	12MSC6N	3/4	3/8	1.796	.969	.859	.562	.375	1.405	1-1/8	1-1/8
12-DMC-8	1210-1-8	12MSC8N	3/4	1/2	1.984	.969	.859	.750	.468	1.593	1-1/8	1-1/16
12-DMC-12	1210-1-12	12MSC12N	3/4	3/4	1.984	.969	.859	.750	.625	1.593	1-1/8	1-1/16
12-DMC-16	1210-1-16	12MSC16N	3/4	1	2.250	.969	.859	.937	.625	1.859	1-1/8	1-3/8
14-DMC-8	1410-1-8	14MSC8N	7/8	1/2	1.984	1.015	.859	.750	.468	1.593	1-1/4	1-1/4
14-DMC-12	1410-1-12	14MSC12N	7/8	3/4	1.984	1.015	.859	.750	.625	1.593	1-1/4	1-3/16
14-DMC-16	1410-1-16	14MSC16N	7/8	1	2.250	1.015	.859	.937	.718	1.859	1-1/4	1-3/8
16-DMC-4	1610-1-4	16MSC4N	1	1/4	2.055	1.234	1.046	.562	.281	1.562	1-1/2	1-3/8
16-DMC-6	1610-1-6	16MSC6N	1	3/8	2.055	1.234	1.046	.562	.375	1.562	1-1/2	1-3/8
16-DMC-8	1610-1-8	16MSC8N	1	1/2	2.265	1.234	1.046	.750	.468	1.781	1-1/2	1-3/8
16-DMC-12	1610-1-12	16MSC12N	1	3/4	2.265	1.234	1.046	.750	.625	1.781	1-1/2	1-3/8
16-DMC-16	1610-1-16	16MSC16N	1	1	2.453	1.234	1.046	.937	.875	1.969	1-1/2	1-3/8

NOTE: All dimensions subject to change, to be used for reference only.

¹ The E dimension is the minimum opening. These fittings may have a larger opening at the pipe/straight thread end.

O-Ring Straight Thread Male Connector

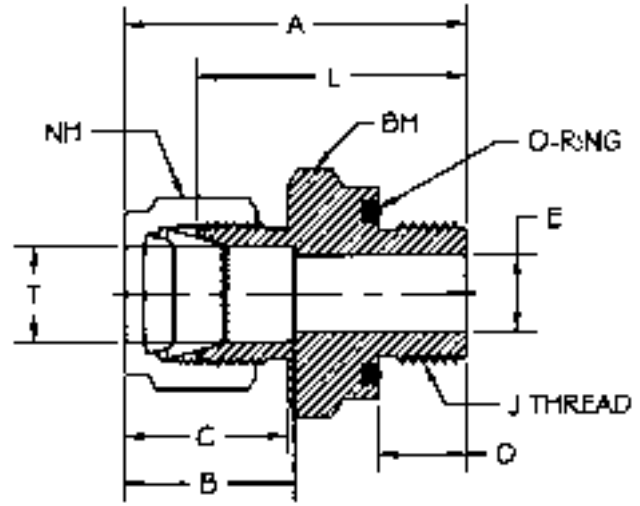
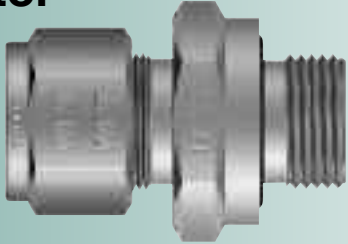

PART NUMBER	INTERCHANGES WITH	T TUBE O.D.	J SAE/MS THREAD	A	B	C	D	E ¹ THRU HOLE	L	NH NUT HEX	BH BODY HEX	O-RING
1-DMC-ORS	100-1-OR 1M2SC1	1/16	5/16-24	1.047	.344	.437	.343	.047	.906	5/16	9/16	AS-011
2-DMC-ORS	200-1-OR 2M2SC2	1/8	5/16-24	1.297	.500	.609	.343	.094	1.031	7/16	9/16	AS-011
3-DMC-ORS	300-1-OR 3M2SC3	3/16	3/8-24	1.359	.547	.625	.375	.125	1.094	1/2	5/8	AS-012
4-DMC-ORS	400-1-OR 4M2SC4	1/4	7/16-20	1.516	.609	.703	.406	.187	1.219	9/16	3/4	AS-111
5-DMC-ORS	500-1-OR 5M2SC5	5/16	1/2-20	1.609	.641	.734	.437	.250	1.312	5/8	7/8	AS-112
6-DMC-ORS	600-1-OR 6M2SC6	3/8	9/16-18	1.672	.656	.766	.468	.281	1.375	11/16	15/16	AS-113
8-DMC-ORS	810-1-OR 8M2SC8	1/2	3/4-16	1.812	.906	.859	.468	.406	1.406	7/8	1-1/8	AS-116
12-DMC-ORS	1210-1-OR 12M2SC12	3/4	1-1/16-12	2.062	.969	.859	.562	.625	1.656	1-1/8	1-1/2	AS-215
16-DMC-ORS	1610-1-OR 16M2SC16	1	1-5/16-12	2.297	1.234	1.047	.562	.875	1.812	1-1/2	1-3/4	AS-219

*NOTE: All dimensions subject to change, to be used for reference only.

**NOTE: Stainless steel and carbon steel O-seal fittings up to 1 inch are rated to 3000 psi.

¹ The E dimension is the minimum opening. These fittings may have a larger opening at the pipe/straight thread end.

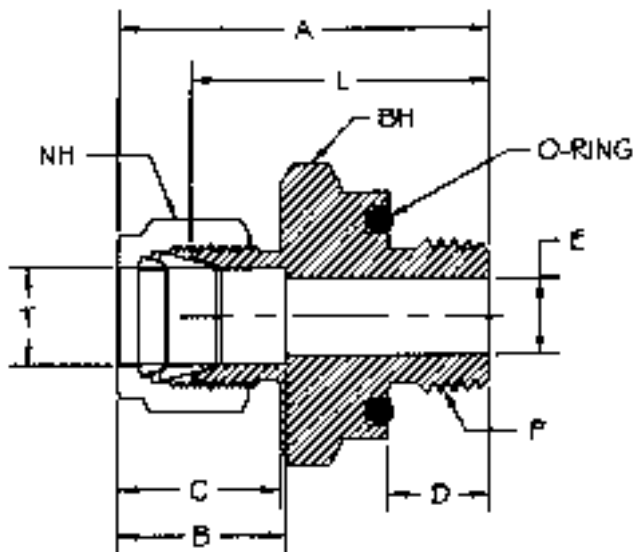

PART NUMBER	INTERCHANGES WITH		T TUBE O.D.	P PIPE END NPT	A	B	C	D	E ¹ THRU HOLE	L	NH NUT HEX	BH BODY HEX	O-RING
2-DMC-2-ORT	200-1-2-OR	2M3SC2	1/8	1/8	1.297	.500	.609	.280	.094	1.031	7/16	3/4	AS-111
4-DMC-2-ORT	400-1-2-OR	4M3SC2	1/4	1/8	1.375	.609	.703	.280	.187	1.094	9/16	3/4	AS-111
4-DMC-4-ORT	400-1-4-OR	4M3SC4	1/4	1/4	1.516	.609	.703	.375	.187	1.219	9/16	15/16	AS-113
6-DMC-4-ORT	600-1-4-OR	6M3SC4	3/8	1/4	1.570	.656	.766	.703	.281	1.281	11/16	15/16	AS-113
6-DMC-6-ORT	600-1-6-OR	6M3SC6	3/8	3/8	1.625	.656	.766	.406	.281	1.344	11/16	1-1/8	AS-116
6-DMC-8-ORT	600-1-8-OR	6M3SC8	3/8	1/2	1.859	.656	.766	.531	.281	1.562	11/16	1-3/8	AS-212
8-DMC-8-ORT	810-1-8-OR	8M3SC8	1/2	1/2	1.969	.906	.859	.531	.406	1.562	7/8	1-3/8	AS-212

*NOTE: All dimensions subject to change, to be used for reference only.

**NOTE: Stainless steel and carbon steel O-seal fittings up to 1 inch are rated to 3000 psi.

¹ The E dimension is the minimum opening. These fittings may have a larger opening at the pipe/straight thread end.

Mounting Dimensions for ORS/ORT Fittings

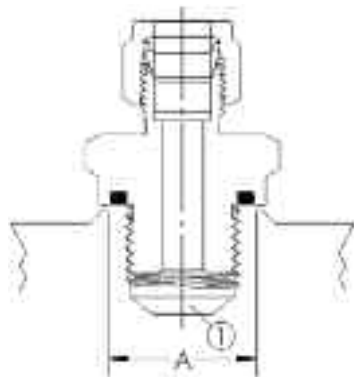

Raised Surface

Minimum diameter is larger than the O-ring sealing diameter to prevent O-ring extrusion.

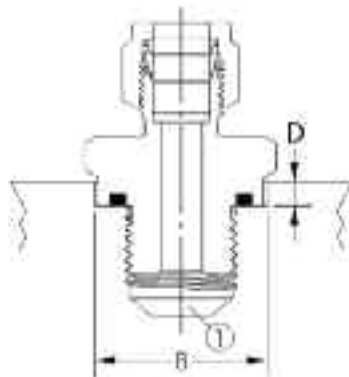

Recessed Hole (Shoulder clearance)

Minimum diameter allows clearance for round shoulder of fitting into recess.

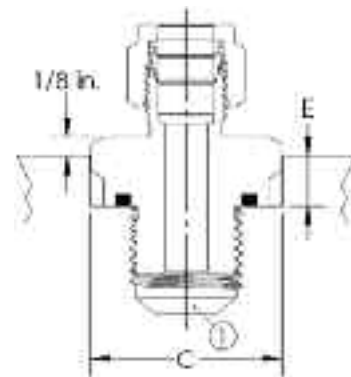

Recessed Hole (Hex clearance)

Minimum diameter allows clearance for hex of fitting into recess.

TUBE O.D.	SAE/MS THREAD	NPT SIZE	A MIN DIA	B MIN DIA	C MIN DIA	D MAX DEPTH	E MAX DEPTH
1/16	5/16-24	-	0.50	0.59	0.66	0.09	0.16
1/8	5/16-24	-	0.50	0.59	0.66	0.09	0.22
1/8	-	1/8	0.69	0.78	0.88	0.16	0.28
3/16	3/8-24	-	0.56	0.66	0.75	0.09	0.22
1/4	7/16-20	-	0.69	0.78	0.88	0.16	0.28
1/4	-	1/8	0.69	0.78	0.88	0.16	0.28
1/4	-	1/4	0.87	0.97	1.09	0.16	0.31
5/16	1/2-20	-	0.75	0.91	1.03	0.16	0.31
3/8	9/16-18	-	0.81	0.97	1.09	0.16	0.31
3/8	-	1/4	0.87	0.97	1.09	0.16	0.31
3/8	-	3/8	1.00	1.16	1.31	0.16	0.34
3/8	-	1/2	1.22	1.34	1.60	0.22	0.44
1/2	3/4-16	-	1.00	1.16	1.31	0.16	0.34
1/2	-	1/2	1.22	1.34	1.60	0.22	0.44
3/4	1 1/16-12	-	1.41	1.53	1.75	0.22	0.50
1	1 5/16-12	-	1.69	1.78	2.03	0.22	0.56

① Allow clearance for (1) full thread.

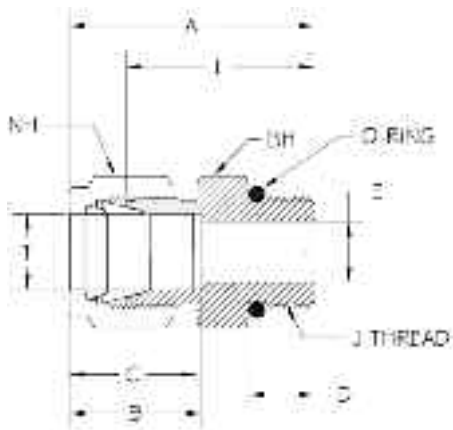

Straight Thread Boss Male Connector



PART NUMBER	INTERCHANGES WITH	T TUBE O.D.	J SAE/MS THREAD	A	B	C	D	E ¹ THRU HOLE	L	NH NUT HEX	BH BODY HEX	O-RING
2-DMC-2-STB	200-1-2ST 2M1SC2	1/8	5/16-24	1.18	.50	.61	.30	.09	.92	7/16	7/16	AS-902
4-DMC-4-STB	400-1-4ST 4M1SC4	1/4	7/16-20	1.34	.61	.70	.36	.19	1.05	9/16	9/16	AS-904
5-DMC-5-STB	500-1-5ST 5M1SC5	5/16	1/2-20	1.37	.64	.73	.36	.25	1.08	5/8	5/8	AS-905
6-DMC-6-STB	600-1-6ST 6M1SC6	3/8	9/16-18	1.46	.66	.77	.39	.28	1.17	11/16	11/16	AS-906
8-DMC-8-STB	810-1-8ST 8M1SC8	1/2	3/4-16	1.65	.91	.86	.44	.41	1.25	7/8	7/8	AS-908
10-DMC-10-STB	1010-1-10ST 10M1SC10	5/8	7/8-14	1.78	.97	.86	.50	.50	1.37	1	1	AS-910
12-DMC-12-STB	1210-1-12ST 12M1SC12	3/4	1-1/16-12	1.93	.97	.86	.59	.63	1.53	1-1/8	1-1/4	AS-912
14-DMC-14-STB	1410-1-14ST 14M1SC14	7/8	1-3/16-12	1.93	1.02	.86	.59	.72	1.53	1-1/4	1-3/8	AS-914
16-DMC-16-STB	1610-1-16ST 16M1SC16	1	1-5/16-12	2.14	1.23	1.05	.59	.88	1.66	1-1/2	1-1/2	AS-916

NOTE: All dimensions subject to change, to be used for reference only.

¹ The E dimension is the minimum opening. These fittings may have a larger opening at the pipe/straight thread end.

Adapts to SAE J1926/1 and ISO 11926-1 straight thread boss.

*NOTE: All dimensions subject to change, to be used for reference only.

Port Connector Union

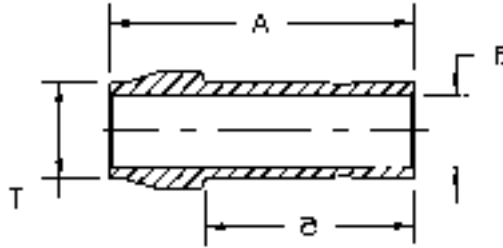
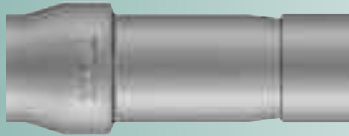

PART NUMBER	INTERCHANGES WITH		T TUBE O.D.	A	B	E THRU HOLE
1-DPCU	101-PC	1PC1	1/16	.547	.422	.031
2-DPCU	201-PC	2PC2	1/8	.875	.625	.094
4-DPCU	401-PC	4PC4	1/4	.969	.734	.187
5-DPCU	501-PC	5PC5	5/16	1.016	.797	.250
6-DPCU	601-PC	6PC6	3/8	1.031	.797	.297
8-DPCU	811-PC	8PC8	1/2	1.406	1.016	.391
12-DPCU	1211-PC	12PC12	3/4	1.469	1.094	.594
16-DPCU	1611-PC	16PC16	1	1.906	1.359	.812

*NOTE: All dimensions subject to change, to be used for reference only.

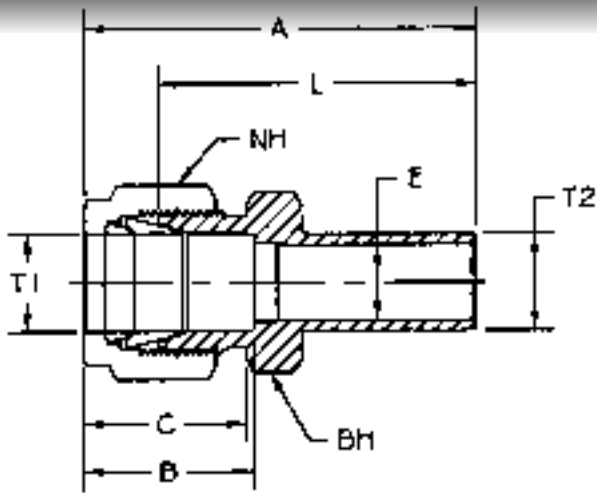

Reducer Adapter Tube to Tube

PART NUMBER	INTERCHANGES WITH	T1 TUBE O.D.	T2 TUBE O.D.	A	B	C	E THRU HOLE	L	NH NUT HEX	BH BODY HEX	
1-DRATT-2	100-R-2	2TUR1	1/16	1/8	1.156	.344	.437	.052	1.000	5/16	5/16
1-DRATT-4	100-R-4	4TUR1	1/16	1/4	1.234	.344	.437	.052	1.094	5/16	5/16
2-DRATT-1	200-R-1	1TUR2	1/8	1/16	1.141	.500	.609	.031	.875	7/16	7/16
2-DRATT-2	200-R-2	2TUR2	1/8	1/8	1.328	.500	.609	.078	1.062	7/16	7/16
2-DRATT-3	200-R-3	3TUR2	1/8	3/16	1.359	.500	.609	.094	1.094	7/16	7/16
2-DRATT-4	200-R-4	4TUR2	1/8	1/4	1.422	.500	.609	.094	1.156	7/16	7/16
2-DRATT-6	200-R-6	6TUR2	1/8	3/8	1.484	.500	.609	.094	1.219	7/16	7/16
2-DRATT-8	200-R-8	8TUR2	1/8	1/2	1.734	.500	.609	.094	1.484	7/16	9/16
3-DRATT-2	300-R-2	2TUR3	3/16	1/8	1.375	.547	.625	.078	1.109	1/2	7/16
3-DRATT-4	300-R-4	4TUR3	3/16	1/4	1.469	.547	.625	.125	1.203	1/2	7/16
4-DRATT-2	400-R-2	2TUR4	1/4	1/8	1.453	.609	.703	.078	1.156	9/16	1/2
4-DRATT-4	400-R-4	4TUR4	1/4	1/4	1.547	.609	.703	.187	1.250	9/16	1/2
4-DRATT-5	400-R-5	5TUR4	1/4	5/16	1.578	.609	.703	.187	1.281	9/16	1/2
4-DRATT-6	400-R-6	6TUR4	1/4	3/8	1.609	.609	.703	.187	1.312	9/16	1/2
4-DRATT-8	400-R-8	8TUR4	1/4	1/2	1.828	.609	.703	.187	1.531	9/16	9/16
4-DRATT-10	400-R-10	10TUR4	1/4	5/8	1.891	.609	.703	.187	1.609	9/16	11/16
5-DRATT-6	500-R-6	6TUR5	5/16	3/8	1.656	.641	.734	.250	1.359	5/8	9/16
5-DRATT-8	500-R-8	8TUR5	5/16	1/2	1.875	.641	.734	.250	1.578	5/8	9/16
6-DRATT-6	600-R-6	6TUR6	3/8	3/8	1.703	.656	.766	.281	1.406	11/16	5/8
6-DRATT-8	600-R-8	8TUR6	3/8	1/2	1.922	.656	.766	.281	1.625	11/16	5/8
6-DRATT-10	600-R-10	10TUR6	3/8	5/8	1.984	.656	.766	.281	1.687	11/16	11/16
6-DRATT-12	600-R-12	12TUR6	3/8	3/4	1.984	.656	.766	.281	1.687	11/16	13/16
8-DRATT-4	810-R-4	4TUR8	1/2	1/4	1.766	.906	.859	.187	1.375	7/8	13/16
8-DRATT-6	810-R-6	6TUR8	1/2	3/8	1.844	.906	.859	.281	1.437	7/8	13/16
8-DRATT-8	810-R-8	8TUR8	1/2	1/2	2.062	.906	.859	.406	1.656	7/8	13/16
8-DRATT-10	810-R-10	10TUR8	1/2	5/8	2.125	.906	.859	.406	1.719	7/8	13/16
8-DRATT-12	810-R-12	12TUR8	1/2	3/4	2.125	.906	.859	.406	1.719	7/8	13/16
8-DRATT-16	810-R-16	16TUR8	1/2	1	2.375	.906	.859	.406	1.969	7/8	1-1/16
10-DRATT-12	1010-R-12	12TUR10	5/8	3/4	2.156	.969	.859	.500	1.750	1	15/16
10-DRATT-14	1010-R-14	14TUR10	5/8	7/8	2.219	.969	.859	.500	1.812	1	15/16
10-DRATT-16	1010-R-16	16TUR10	5/8	1	2.406	.969	.859	.500	2.000	1	1-1/16
12-DRATT-8	1210-R-8	8TUR12	3/4	1/2	2.156	.969	.859	.391	1.750	1-1/8	1-1/16
12-DRATT-16	1210-R-16	16TUR12	3/4	1	2.469	.969	.859	.625	2.062	1-1/8	1-1/16

*NOTE: All dimensions subject to change, to be used for reference only.

Reducing Port Connector

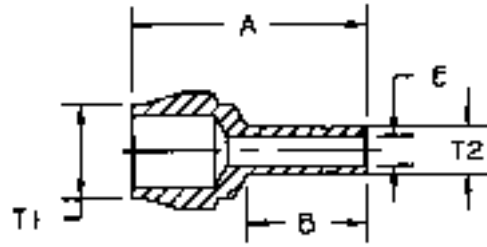
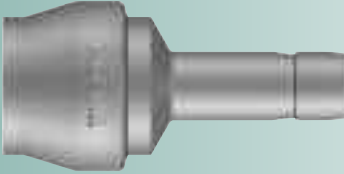

PART NUMBER	INTERCHANGES WITH	T1 TUBE O.D.	T2 TUBE O.D.	A	B	E THRU HOLE	
2-DRPC-1	201-PC-1	1PC2	1/8	1/16	.687	.344	.031
4-DRPC-1	401-PC-1	1PC4	1/4	1/16	.719	.344	.031
4-DRPC-2	402-PC-2	2PC4	1/4	1/8	.891	.531	.094
6-DRPC-2	601-PC-2	2PC6	3/8	1/8	.906	.531	.094
6-DRPC-4	601-PC-4	4PC6	3/8	1/4	.984	.625	.187
8-DRPC-4	811-PC-4	4PC8	1/2	1/4	1.156	.625	.187
8-DRPC-6	811-PC-6	6PC8	1/2	3/8	1.203	.687	.281
12-DRPC-8	1211-PC-8	8PC12	3/4	1/2	1.437	.906	.391

*NOTE: All dimensions subject to change, to be used for reference only.

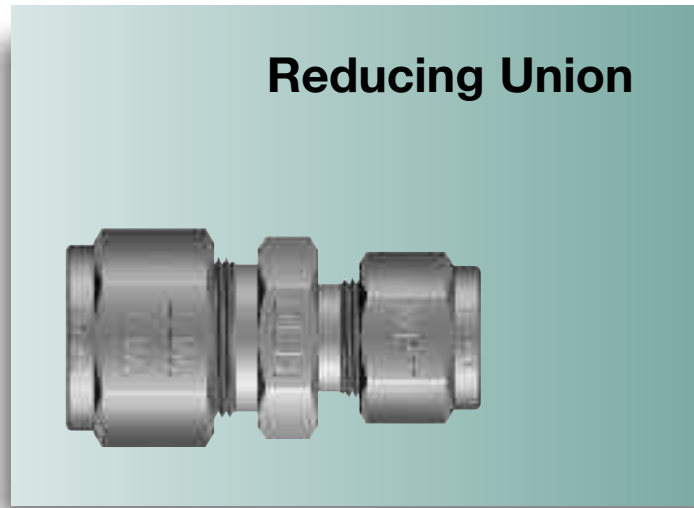
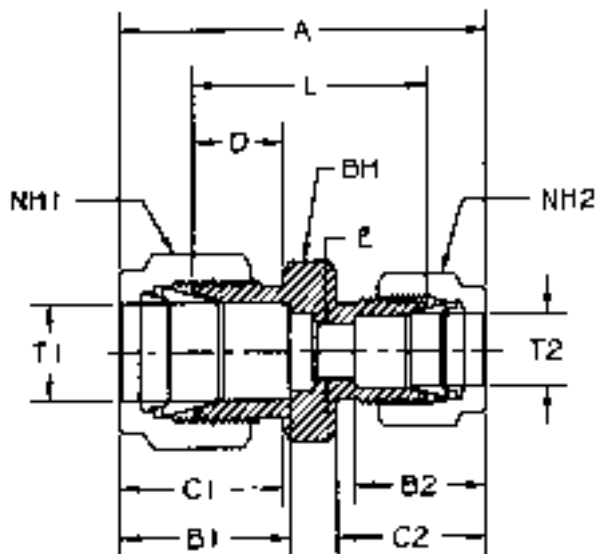

Reducing Union

PART NUMBER	INTERCHANGES WITH	T1 TUBE O.D.	T2 TUBE O.D.	A	B1	B2	C1	C2	D	E THRU HOLE	L	NH1 NUT HEX	NH2 NUT HEX	BH BODY HEX	
2-DRU-1	200-6-1	2RU1	1/8	1/16	1.219	.500	.344	.609	.437	.343	.052	.812	7/16	5/16	7/16
3-DRU-1	300-6-1	3RU1	3/16	1/16	1.266	.547	.344	.625	.437	.375	.052	.859	1/2	5/16	7/16
3-DRU-2	300-6-2	3RU2	3/16	1/8	1.437	.547	.500	.625	.609	.375	.094	.922	1/2	7/16	7/16
4-DRU-2	400-6-2	4RU2	1/4	1/8	1.516	.609	.500	.703	.609	.406	.094	.969	9/16	7/16	1/2
4-DRU-3	400-6-3	4RU3	1/4	3/16	1.547	.609	.547	.703	.625	.406	.125	1.000	9/16	1/2	1/2
5-DRU-2	500-6-2	5RU2	5/16	1/8	1.578	.641	.500	.734	.609	.437	.094	1.016	5/8	7/16	9/16
5-DRU-4	500-6-4	5RU4	5/16	1/4	1.656	.641	.609	.734	.703	.437	.187	1.078	5/8	9/16	9/16
6-DRU-1	600-6-1	6RU1	3/8	1/16	1.437	.656	.344	.765	.437	.468	.052	1.000	11/16	5/16	5/8
6-DRU-2	600-6-2	6RU2	3/8	1/8	1.609	.656	.500	.765	.609	.468	.094	1.062	11/16	7/16	5/8
6-DRU-4	600-6-4	6RU4	3/8	1/4	1.703	.656	.609	.765	.703	.468	.187	1.125	11/16	9/16	5/8
6-DRU-5	600-6-5	6RU5	3/8	5/16	1.734	.656	.641	.765	.734	.468	.250	1.156	11/16	5/8	5/8
8-DRU-2	810-6-2	8RU2	1/2	1/8	1.781	.906	.500	.859	.609	.468	.094	1.125	7/8	7/16	13/16
8-DRU-4	810-6-4	8RU4	1/2	1/4	1.859	.906	.609	.859	.703	.468	.187	1.156	7/8	9/16	13/16
8-DRU-6	810-6-6	8RU6	1/2	3/8	1.906	.906	.656	.859	.765	.468	.281	1.219	7/8	11/16	13/16
10-DRU-6	1010-6-6	10RU6	5/8	3/8	1.937	.969	.656	.859	.765	.468	.281	1.250	1	11/16	15/16
10-DRU-8	1010-6-8	10RU8	5/8	1/2	2.047	.969	.906	.859	.859	.468	.406	1.250	1	7/8	15/16
12-DRU-4	1210-6-4	12RU4	3/4	1/4	1.937	.969	.609	.859	.703	.468	.187	1.250	1-1/8	9/16	1-1/16
12-DRU-6	1210-6-6	12RU6	3/4	3/8	2.000	.969	.656	.859	.765	.468	.281	1.312	1-1/8	11/16	1-1/16
12-DRU-8	1210-6-8	12RU8	3/4	1/2	2.109	.969	.906	.859	.859	.468	.406	1.312	1-1/8	7/8	1-1/16
12-DRU-10	1210-6-10	12RU10	3/4	5/8	2.109	.969	.969	.859	.859	.468	.500	1.312	1-1/8	1	1-1/16
16-DRU-12	1610-6-12	16RU12	1	3/4	2.469	1.234	.969	1.047	.859	.562	.625	1.594	1-1/2	1-1/8	1-3/8

*NOTE: All dimensions subject to change, to be used for reference only.

Tube to Butt Weld Connector

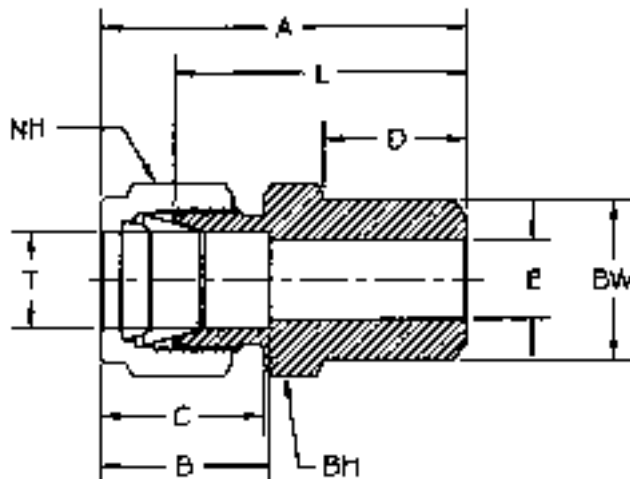

PART NUMBER	INTERCHANGES WITH		T TUBE O.D.	BW	A	B	C	D	E ¹ THRU HOLE	L	NH NUT HEX	BH BODY HEX
2-DTBW-2	200-1-2W	2-1/8 ZHLW2	1/8	.405	1.203	.500	.609	.375	.094	.937	7/16	7/16
3-DTBW-2	300-1-2W	3-1/8 ZHLW2	3/16	.405	1.234	.547	.625	.375	.125	.969	1/2	7/16
4-DTBW-2	400-1-2W	4-1/8 ZHLW2	1/4	.405	1.297	.609	.703	.375	.187	1.000	9/16	1/2
4-DTBW-4	400-1-4W	4-1/4 ZHLW2	1/4	.540	1.484	.609	.703	.562	.187	1.203	9/16	9/16
5-DTBW-4	500-1-4W	5-1/4 ZHLW2	5/16	.540	1.516	.641	.734	.562	.250	1.234	5/8	9/16
6-DTBW-4	600-1-4W	6-1/4 ZHLW2	3/8	.540	1.578	.656	.766	.562	.281	1.281	11/16	5/8
6-DTBW-6	600-1-6W	6-3/8 ZHLW2	3/8	.675	1.578	.656	.766	.562	.281	1.281	11/16	3/4
6-DTBW-8	600-1-8W	6-1/2 ZHLW2	3/8	.840	1.828	.656	.766	.750	.281	1.531	11/16	7/8
8-DTBW-6	810-1-6W	8-3/8 ZHLW2	1/2	.675	1.719	.906	.859	.562	.406	1.312	7/8	13/16
8-DTBW-8	810-1-8W	8-1/2 ZHLW2	1/2	.840	1.937	.906	.859	.750	.406	1.531	7/8	7/8
8-DTBW-12	810-1-12W	8-3/4 ZHLW2	1/2	1.050	1.984	.906	.859	.750	.406	1.594	7/8	1-1/16
10-DTBW-8	1010-1-8W	10-1/2 ZHLW2	5/8	.840	1.937	.969	.859	.750	.500	1.531	1	15/16
12-DTBW-12	1210-1-12W	12-3/4 ZHLW2	3/4	1.050	1.984	.969	.859	.750	.625	1.594	1-1/8	1-1/16
16-DTBW-16	1610-1-16W	16-1 ZHLW2	1	1.315	2.453	1.234	1.047	.937	.875	1.969	1-1/2	1-3/8

*NOTE: All dimensions subject to change, to be used for reference only.

¹ The E dimension is the minimum opening. These fittings may have a larger opening at the pipe/straight thread end.

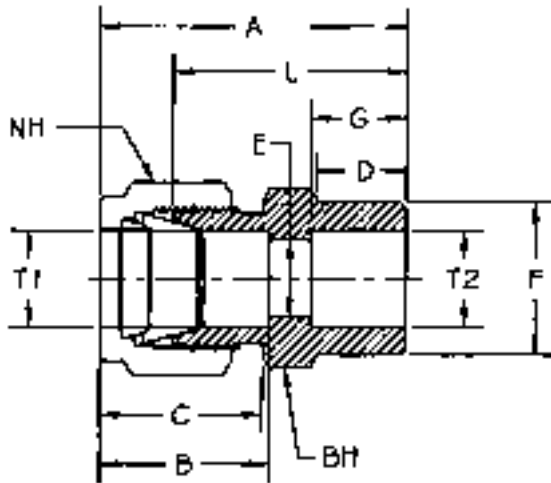

Tube to Socket Weld Connector



PART NUMBER	INTERCHANGES WITH	T1 TUBE O.D.	T2 TUBE O.D.	A	B	C	D	E THRU HOLE	F	G	L	NH NUT HEX	BH BODY HEX
2-DTSW-2	200-6-2W 2-2 ZHLW	1/8	1/8	1.141	.500	.609	.344	.094	.312	.250	.875	7/16	7/16
3-DTSW-3	300-6-3W 3-3 ZHLW	3/16	3/16	1.172	.547	.641	.375	.125	.422	.203	.906	1/2	7/16
4-DTSW-4	400-6-4W 4-4 ZHLW	1/4	1/4	1.328	.609	.703	.406	.187	.437	.312	1.031	9/16	1/2
6-DTSW-6	600-6-6W 6-6 ZHLW	3/8	3/8	1.484	.656	.766	.469	.281	.609	.375	1.187	11/16	5/8
8-DTSW-8	810-6-8W 8-8 ZHLW	1/2	1/2	1.625	.906	.859	.469	.406	.750	.500	1.219	7/8	13/16
10-DTSW-10	1010-6-10W 10-10 ZHLW	5/8	5/8	1.656	.969	.859	.469	.500	.922	.500	1.250	1	15/16
12-DTSW-12	1210-6-12W 12-12 ZHLW	3/4	3/4	1.719	.969	.859	.469	.625	1.047	.562	1.312	1-1/8	1-1/16
16-DTSW-16	1610-6-16W 16-16 ZHLW	1	1	2.078	1.234	1.047	.562	.875	1.312	.750	1.594	1-1/2	1-3/8

*NOTE: All dimensions subject to change, to be used for reference only.

Union

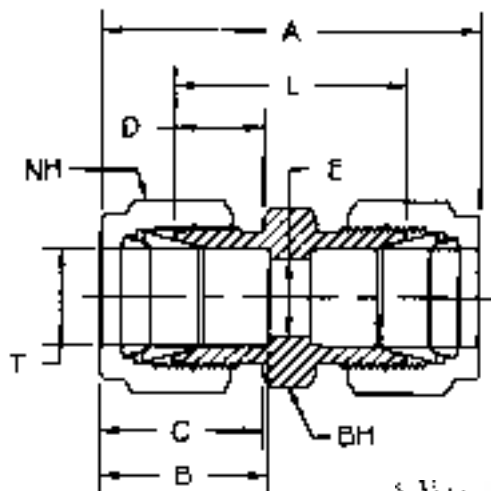
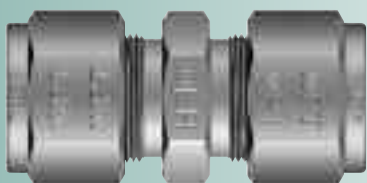

PART NUMBER	INTERCHANGES WITH	T TUBE O.D.	A	B	C	D	E THRU HOLE	L	NH NUT HEX	BH BODY HEX
1-DU	100-6 1SC1	1/16	.984	.344	.437	.281	.052	.687	5/16	5/16
2-DU	200-6 2SC2	1/8	1.406	.500	.609	.343	.094	.875	7/16	7/16
3-DU	300-6 3SC3	3/16	1.469	.547	.625	.375	.125	.953	1/2	7/16
4-DU	400-6 4SC4	1/4	1.609	.609	.703	.406	.187	1.031	9/16	1/2
5-DU	500-6 5SC5	5/16	1.687	.641	.734	.437	.250	1.109	5/8	9/16
6-DU	600-6 6SC6	3/8	1.766	.656	.766	.468	.281	1.187	11/16	5/8
8-DU	810-6 8SC8	1/2	2.016	.906	.859	.468	.406	1.219	7/8	13/16
10-DU	1010-6 10SC10	5/8	2.047	.969	.859	.468	.500	1.250	1	15/16
12-DU	1210-6 12SC12	3/4	2.109	.969	.859	.468	.625	1.312	1-1/8	1-1/16
14-DU	1410-6 14SC14	7/8	2.187	1.016	.859	.468	.718	1.375	1-1/4	1-3/16
16-DU	1610-6 16SC16	1	2.547	1.234	1.047	.562	.875	1.594	1-1/2	1-3/8

*NOTE: All dimensions subject to change, to be used for reference only.

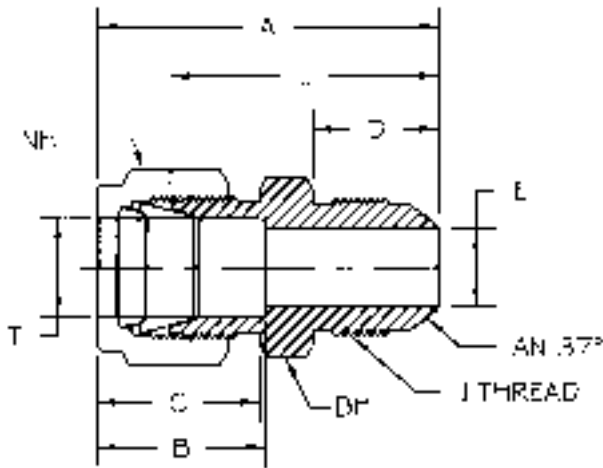

Tube to AN Flare Union

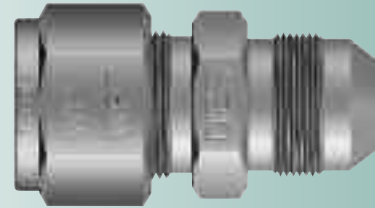

PART NUMBER	INTERCHANGES WITH	T TUBE O.D.	J THREAD	A	B	C	D	E ¹ THRU HOLE	L	NH NUT HEX	BH BODY HEX	
2-DUANF-2	200-6-2AN	2XASC2	1/8	5/16-24	1.234	.500	.609	.448	.062	.984	7/16	7/16
2-DUANF-4	200-6-4AN	4XASC2	1/8	7/16-20	1.375	.500	.609	.550	.094	1.125	7/16	1/2
3-DUANF-3	300-6-3AN	3XASC3	3/16	3/8-24	1.328	.547	.641	.479	.125	1.062	1/2	7/16
4-DUANF-4	400-6-4AN	4XASC4	1/4	7/16-20	1.484	.609	.703	.550	.172	1.187	9/16	1/2
5-DUANF-5	500-6-5AN	5XASC5	5/16	1/2-20	1.516	.641	.734	.550	.234	1.219	5/8	9/16
6-DUANF-4	600-6-4AN	4XASC6	3/8	7/16-20	1.562	.656	.766	.550	.172	1.266	11/16	5/8
6-DUANF-6	600-6-6AN	6XASC6	3/8	9/16-18	1.562	.656	.766	.556	.297	1.266	11/16	5/8
8-DUANF-8	810-6-8AN	8XASC8	1/2	3/4-16	1.812	.906	.859	.657	.391	1.406	7/8	13/16
10-DUANF-10	1010-6-10AN	10XASC10	5/8	7/8-14	1.937	.969	.875	.758	.484	1.531	1	15/16
12-DUANF-12	1210-6-12AN	12XASC12	3/4	1-1/16-12	2.109	.969	.859	.864	.609	1.703	1-1/8	1-1/8
16-DUANF-16	1610-6-16AN	16XASC16	1	1-5/16-12	2.422	1.234	1.047	.911	.844	1.937	1-1/2	1-3/8

*NOTE: All dimensions subject to change, to be used for reference only.

¹ The E dimension is the minimum opening. These fittings may have a larger opening at the pipe/straight thread end.

Union Elbow

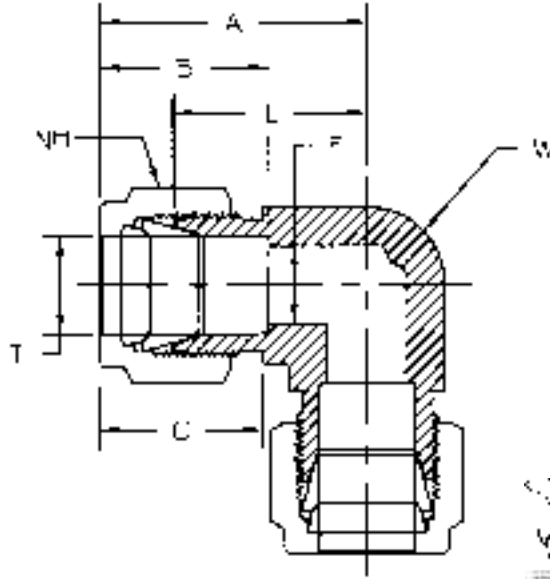

PART NUMBER	INTERCHANGES WITH		T TUBE O.D.	A	B	C	E THRU HOLE	L	NH NUT HEX	W WRENCH FLAT
1-DELU-1	100-9	1EE1	1/16	.750	.344	.437	.052	.609	5/16	7/16
2-DELU-2	200-9	2EE2	1/8	.875	.500	.609	.094	.625	7/16	3/8
3-DELU-3	300-9	3EE3	3/16	1.000	.547	.625	.125	.734	1/2	1/2
4-DELU-4	400-9	4EE4	1/4	1.062	.609	.703	.187	.766	9/16	1/2
5-DELU-5	500-9	5EE5	5/16	1.125	.640	.734	.250	.844	5/8	9/16
6-DELU-6	600-9	6EE6	3/8	1.203	.656	.766	.281	.906	11/16	5/8
8-DELU-8	810-9	8EE8	1/2	1.421	.906	.859	.406	1.016	7/8	13/16
10-DELU-10	1010-9	10EE10	5/8	1.500	.969	.859	.500	1.109	1	15/16
12-DELU-12	1210-9	12EE12	3/4	1.578	.969	.859	.625	1.171	1-1/8	1-1/16
14-DELU-14	1410-9	14EE14	7/8	1.766	1.016	.859	.718	1.406	1-1/4	1-3/8
16-DELU-16	1610-9	16EE16	1	1.937	1.234	1.047	.875	1.438	1-1/2	1-3/8

*NOTE: All dimensions subject to change, to be used for reference only.

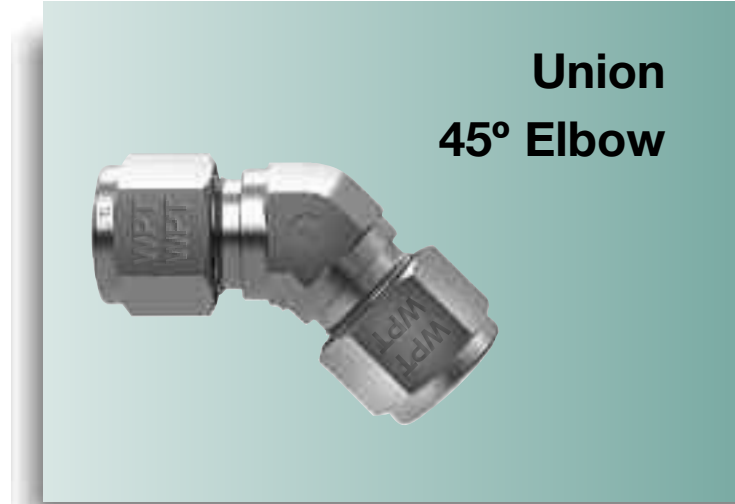
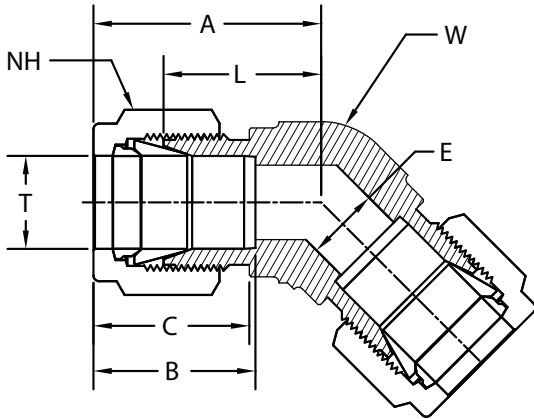

**Union
45° Elbow**

PART NUMBER	T TUBE O.D.	A	B	C	E THRU HOLE	L	NH NUT HEX	W WRENCH FLAT
4-DELU45-4	1/4	.97	.60	.70	.19	.68	9/16	1/2
6-DELU45-6	3/8	1.10	.66	.77	.28	.81	11/16	5/8
8-DELU45-8	1/2	1.26	.90	.86	.41	.86	7/8	13/16

*NOTE: All dimensions subject to change, to be used for reference only.

Female Elbow

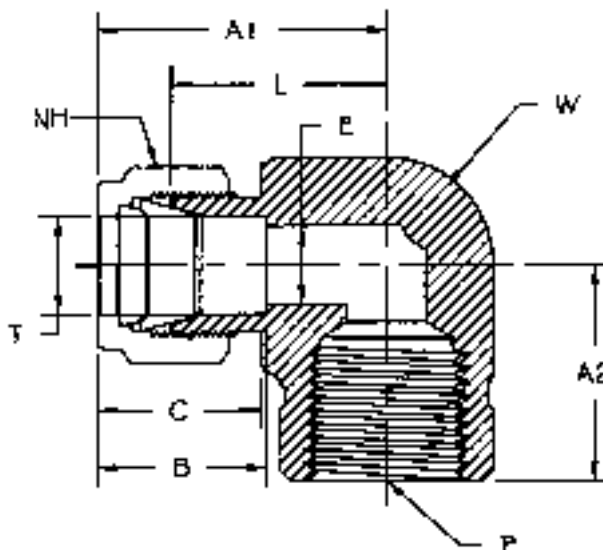
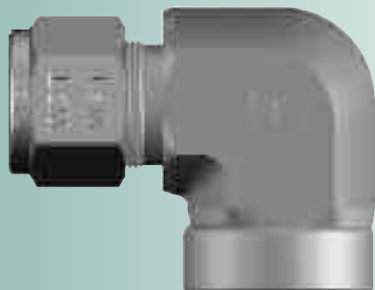

PART NUMBER	INTERCHANGES WITH	T TUBE O.D.	P PIPE END NPT	A1	A2	B	C	E THRU HOLE	L	NH NUT HEX	W WRENCH FLAT	
1-DFE-2	100-8-2	1FEL2N	1/16	1/8	.812	.750	.500	.609	.052	.687	5/16	1/2
2-DFE-2	200-8-2	2FEL2N	1/8	1/8	.969	.750	.500	.609	.094	.719	7/16	1/2
2-DFE-4	200-8-4	2FEL4N	1/8	1/4	1.078	.875	.500	.609	.094	.828	7/16	11/16
3-DFE-2	300-8-2	3FEL2N	3/16	1/8	1.000	.750	.547	.625	.125	.734	1/2	1/2
4-DFE-2	400-8-2	4FEL2N	1/4	1/8	1.062	.750	.609	.703	.187	.781	9/16	1/2
4-DFE-4	400-8-4	4FEL4N	1/4	1/4	1.172	.875	.609	.703	.187	.875	9/16	11/16
4-DFE-6	400-8-6	4FEL6N	1/4	3/8	1.250	.875	.609	.703	.187	.969	9/16	13/16
4-DFE-8	400-8-8	4FEL8N	1/4	1/2	1.359	1.125	.609	.703	.187	1.078	9/16	1
5-DFE-2	500-8-2	5FEL2N	5/16	1/8	1.125	.750	.640	.734	.250	.844	5/8	9/16
5-DFE-4	500-8-4	5FEL4N	5/16	1/4	1.203	.875	.640	.734	.250	.906	5/8	11/16
6-DFE-2	600-8-2	6FEL2N	3/8	1/8	1.203	.750	.656	.766	.281	.906	11/16	5/8
6-DFE-4	600-8-4	6FEL4N	3/8	1/4	1.234	.875	.656	.766	.281	.937	11/16	11/16
6-DFE-6	600-8-6	6FEL6N	3/8	3/8	1.312	.875	.656	.766	.281	1.016	11/16	13/16
6-DFE-8	600-8-8	6FEL8N	3/8	1/2	1.429	1.125	.656	.766	.281	1.125	11/16	1
8-DFE-4	810-8-4	8FEL4N	1/2	1/4	1.429	.875	.906	.859	.406	1.016	7/8	13/16
8-DFE-6	810-8-6	8FEL6N	1/2	3/8	1.429	.875	.906	.859	.406	1.016	7/8	13/16
8-DFE-8	810-8-8	8FEL8N	1/2	1/2	1.531	1.125	.906	.859	.406	1.125	7/8	1
10-DFE-6	1010-8-6	10FEL6N	5/8	3/8	1.500	.875	.969	.859	.500	1.109	1	15/16
10-DFE-8	1010-8-8	10FEL8N	5/8	1/2	1.578	1.125	.969	.859	.500	1.171	1	1-1/16
12-DFE-8	1210-8-8	12FEL8N	3/4	1/2	1.578	1.125	.969	.859	.625	1.171	1-1/8	1-1/16
12-DFE-12	1210-8-12	12FEL12N	3/4	3/4	1.766	1.250	.969	.859	.625	1.359	1-1/8	1-3/8
14-DFE-12	1410-8-12	14FEL12N	7/8	3/4	1.766	1.250	1.016	.859	.718	1.359	1-1/4	1-3/8
16-DFE-12	1610-8-12	16FEL12N	1	3/4	1.937	1.250	1.234	1.049	.875	1.453	1-1/2	1-3/8
16-DFE-16	1610-8-16	16FEL16N	1	1	1.984	1.500	1.234	1.049	.875	1.500	1-1/2	1-11/16

*NOTE: All dimensions subject to change, to be used for reference only.

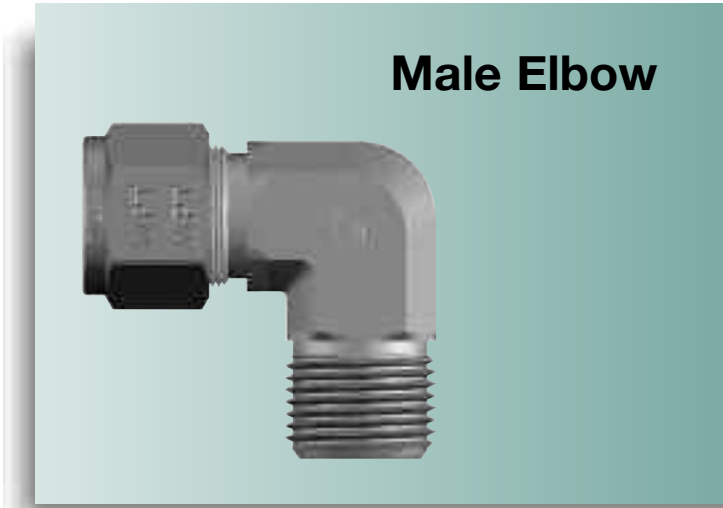
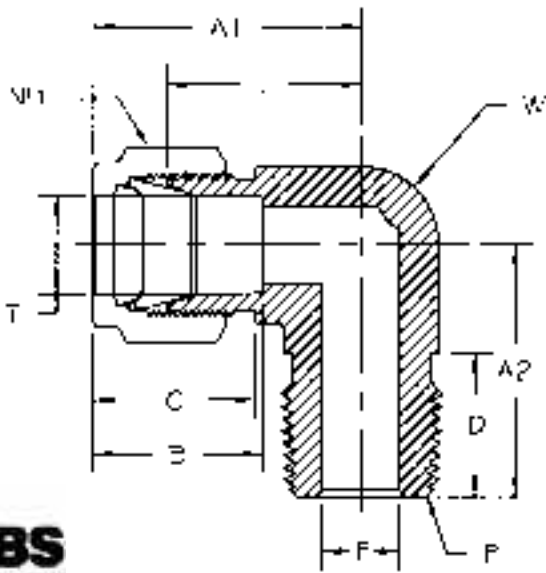

PART NUMBER	INTERCHANGES WITH	T TUBE O.D.	P PIPE END NPT	A1	A2	B	C	D	E ¹ THRU HOLE	L	NH NUT HEX	W WRENCH FLAT	
1-DME-1	100-2-1	1MSEL1N	1/16	1/16	.703	.656	.344	.437	.375	.052	.547	5/16	3/8
1-DME-2	100-2-2	1MSEL2N	1/16	1/8	.750	.703	.344	.437	.375	.052	.609	5/16	7/16
2-DME-1	200-2-1	2MSEL1N	1/8	1/16	.937	.703	.500	.609	.375	.094	.672	7/16	7/16
2-DME-2	200-2-2	2MSEL2N	1/8	1/8	.937	.703	.500	.609	.375	.094	.672	7/16	7/16
2-DME-4	200-2-4	2MSEL4N	1/8	1/4	.969	.922	.500	.609	.562	.094	.719	7/16	1/2
2-DME-6	200-2-6	2MSEL6N	1/8	3/8	1.203	1.125	.500	.609	.562	.094	.812	7/16	13/16
3-DME-2	300-2-2	3MSEL2N	3/16	1/8	1.000	.734	.547	.625	.375	.125	.734	1/2	1/2
3-DME-4	300-2-4	3MSEL4N	3/16	1/4	1.000	.922	.547	.625	.562	.125	.734	1/2	1/2
4-DME-1	400-2-1	4MSEL1N	1/4	1/16	1.203	.703	.609	.703	.375	.156	.719	9/16	1/2
4-DME-2	400-2-2	4MSEL2N	1/4	1/8	1.062	.734	.609	.703	.375	.187	.766	9/16	1/2
4-DME-4	400-2-4	4MSEL4N	1/4	1/4	1.062	.922	.609	.703	.562	.187	.766	9/16	1/2
4-DME-6	400-2-6	4MSEL6N	1/4	3/8	1.172	1.031	.609	.703	.562	.187	.875	9/16	11/16
4-DME-8	400-2-8	4MSEL8N	1/4	1/2	1.250	1.297	.609	.703	.750	.187	.969	9/16	13/16
4-DME-12	400-2-12	4MSEL12N	1/4	3/4	1.546	1.500	.609	.703	.750	.187	1.093	9/16	1-1/16
5-DME-2	500-2-2	5MSEL2N	5/16	1/8	1.125	.781	.641	.734	.375	.187	.844	5/8	9/16
5-DME-4	500-2-4	5MSEL4N	5/16	1/4	1.125	.969	.641	.734	.562	.250	.844	5/8	9/16
5-DME-6	500-2-6	5MSEL6N	5/16	3/8	1.203	1.031	.641	.734	.562	.250	.906	5/8	11/16
6-DME-2	600-2-2	6MSEL2N	3/8	1/8	1.203	.812	.656	.766	.375	.187	.906	11/16	5/8
6-DME-4	600-2-4	6MSEL4N	3/8	1/4	1.203	1.000	.656	.766	.562	.281	.906	11/16	5/8
6-DME-6	600-2-6	6MSEL6N	3/8	3/8	1.234	1.031	.656	.766	.562	.281	.937	11/16	11/16

*NOTE: All dimensions subject to change, to be used for reference only.

¹ The E dimension is the minimum opening. These fittings may have a larger opening at the pipe/straight thread end.

Male Elbow

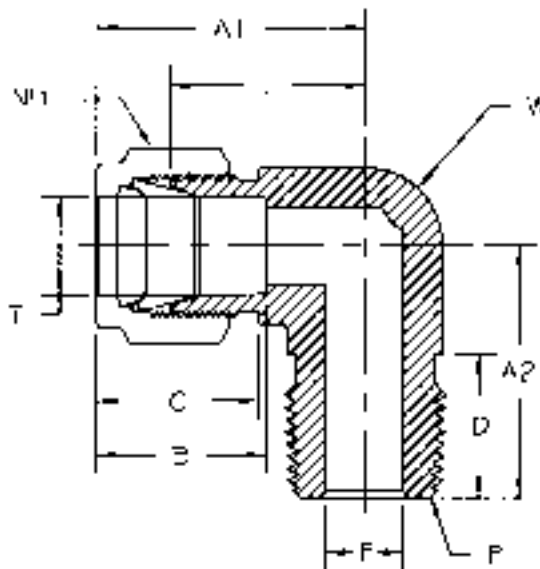
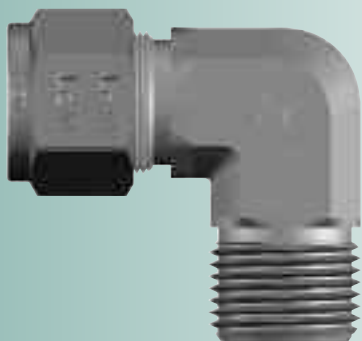

PART NUMBER	INTERCHANGES WITH	T TUBE O.D.	P PIPE END NPT	A1	A2	B	C	D	E ¹ THRU HOLE	L	NH NUT HEX	W WRENCH FLAT
6-DME-8	600-2-8 6MSEL8N	3/8	1/2	1.312	1.297	.656	.766	.750	.281	1.016	11/16	13/16
6-DME-12	600-2-12 6MSEL12N	3/8	3/4	1.469	1.453	.656	.766	.750	.281	1.172	11/16	1-1/16
8-DME-2	810-2-2 8MSEL2N	1/2	1/8	1.609	1.109	.906	.859	.375	.187	.969	7/8	13/16
8-DME-4	810-2-4 8MSEL4N	1/2	1/4	1.422	1.109	.906	.859	.562	.281	1.016	7/8	13/16
8-DME-6	810-2-6 8MSEL6N	1/2	3/8	1.422	1.109	.906	.859	.562	.375	1.016	7/8	13/16
8-DME-8	810-2-8 8MSEL8N	1/2	1/2	1.422	1.297	.906	.859	.750	.406	1.016	7/8	13/16
8-DME-12	810-2-12 8MSEL12N	1/2	3/4	1.578	1.453	.906	.859	.750	.406	1.172	7/8	1-1/16
10-DME-4	1010-2-4 10MSEL4N	5/8	1/4	1.498	1.125	.969	.859	.562	.281	1.093	1	1
10-DME-6	1010-2-6 10MSEL6N	5/8	3/8	1.500	1.187	.969	.859	.562	.375	1.109	1	15/16
10-DME-8	1010-2-8 10MSEL8N	5/8	1/2	1.500	1.375	.969	.859	.750	.469	1.109	1	15/16
10-DME-12	1010-2-12 10MSEL12N	5/8	3/4	1.578	1.453	.969	.859	.750	.500	1.172	1	1-1/16
10-DME-16	1010-2-16 10MSEL16N	5/8	1	1.780	1.844	.969	.859	.937	.500	1.375	1	1-1/2
12-DME-4	1210-2-4 12MSEL4N	3/4	1/4	1.576	1.250	.969	.859	.562	.281	1.375	1-1/8	1-1/16
12-DME-6	1210-2-6 12MSEL6N	3/4	3/8	1.576	1.250	.969	.859	.562	.406	1.375	1-1/8	1-1/16
12-DME-8	1210-2-8 12MSEL8N	3/4	1/2	1.561	1.453	.969	.859	.750	.469	1.172	1-1/8	1-1/16
12-DME-12	1210-2-12 12MSEL12N	3/4	3/4	1.578	1.453	.969	.859	.750	.625	1.172	1-1/8	1-1/16
14-DME-12	1410-2-12 14MSEL12N	7/8	3/4	1.766	1.641	1.016	.859	.750	.625	1.359	1-1/4	1-3/8
16-DME-4	1610-2-4 16MSEL4N	1	1/4	1.935	1.375	1.234	1.047	.562	.281	1.531	1-1/2	1-1/2
16-DME-8	1610-2-8 16MSEL8N	1	1/2	1.935	1.562	1.234	1.047	.750	.500	1.531	1-1/2	1-1/2
16-DME-12	1610-2-12 16MSEL12N	1	3/4	1.937	1.641	1.234	1.047	.937	.625	1.453	1-1/2	1-3/8
16-DME-16	1610-2-16 16MSEL16N	1	1	1.937	1.828	1.234	1.047	.937	.875	1.453	1-1/2	1-3/8

*NOTE: All dimensions subject to change, to be used for reference only.

¹ The E dimension is the minimum opening. These fittings may have a larger opening at the pipe/straight thread end.

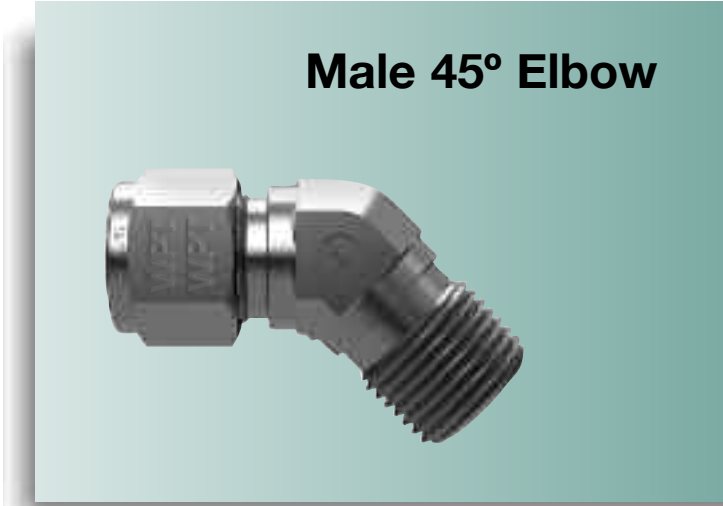
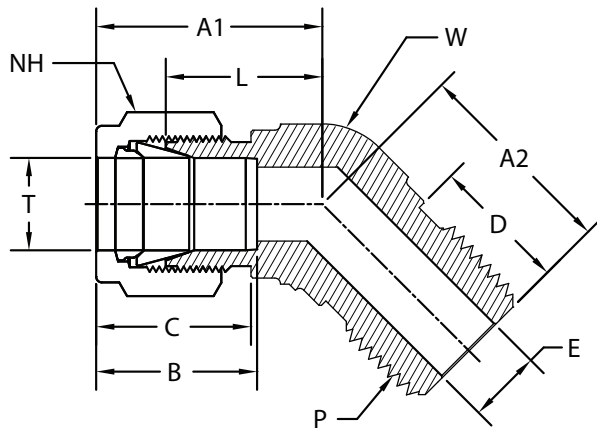

PART NUMBER	INTERCHANGES WITH	T TUBE O.D.	P PIPE END NPT	A1	A2	B	C	D	E ¹ THRU HOLE	L	NH NUT HEX	W WRENCH FLAT
SS-4-DME45-2	400-5-2 4MVEL2N	1/4	1/8	.97	.65	.60	.70	.38	.19	.68	9/16	1/2
SS-4-DME45-4	400-5-4 4MVEL4N	1/4	1/4	.97	.83	.60	.70	.56	.19	.68	9/16	1/2
SS-6-DME45-2	600-5-2 6MVEL2N	3/8	1/8	1.10	.72	.66	.77	.38	.19	.81	11/16	5/8
SS-6-DME45-4	600-5-4 6MVEL4N	3/8	1/4	1.10	.90	.66	.77	.56	.28	.81	11/16	5/8
SS-6-DME45-6	600-5-6 6MVEL6N	3/8	3/8	1.15	.95	.66	.77	.56	.28	.86	11/16	13/16
SS-8-DME45-6	810-5-6 8MVEL6N	1/2	3/8	1.26	.95	.90	.86	.56	.38	.86	7/8	13/16
SS-8-DME45-8	810-5-8 8MVEL8N	1/2	1/2	1.26	1.14	.90	.86	.75	.41	.86	7/8	13/16

*NOTE: All dimensions subject to change, to be used for reference only.

¹ The E dimension is the minimum opening. These fittings may have a larger opening at the pipe/straight thread end.

Available in Stainless Steel Only

Tube to Butt Weld Elbow

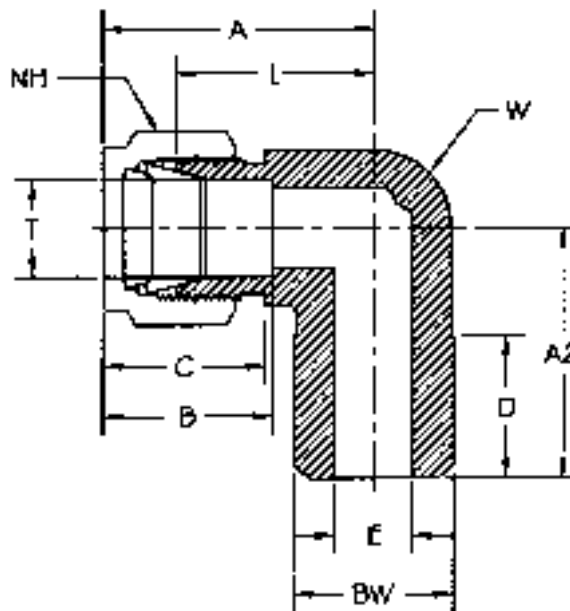

PART NUMBER	INTERCHANGES WITH		T TUBE O.D.	BW	A1	A2	B	C	D	E ¹ THRU HOLE	L	NH NUT HEX	W WRENCH FLAT
2-DTBWE-2	200-2-2W	2-1/8 ZELW2	1/8	.405	.922	.719	.516	.609	.344	.094	.656	7/16	1/2
3-DTBWE-2	300-2-2W	3-1/8 ZELW2	3/16	.405	1.016	.734	.547	.641	.375	.125	.734	1/2	1/2
4-DTBWE-2	400-2-2W	4-1/8 ZELW2	1/4	.405	1.062	.734	.609	.703	.375	.187	.766	9/16	1/2
4-DTBWE-4	400-2-4W	4-1/4 ZELW2	1/4	.540	1.062	.937	.609	.703	.562	.187	.766	9/16	1/2
6-DTBWE-4	600-2-4W	6-1/4 ZELW2	3/8	.540	1.203	1.000	.656	.766	.562	.281	.906	11/16	5/8
8-DTBWE-6	800-2-6W	8-3/8 ZELW2	1/2	.675	1.375	1.125	.906	.859	.562	.406	.969	7/8	13/16
8-DTBWE-8	810-2-8W	8-1/2 ZELW2	1/2	.840	1.422	1.297	.906	.859	.750	.406	1.016	7/8	13/16
10-DTBWE-8	1010-2-8W	10-1/2 ZELW2	5/8	.840	1.437	1.312	.969	.859	.750	.500	1.031	1	7/8
12-DTBWE-12	1210-2-12W	12-3/4 ZELW2	3/4	1.050	1.578	1.453	.969	.859	.750	.625	1.172	1-1/8	1-1/16
16-DTBWE-12	1610-2-12W	16-3/4 ZELW2	1	1.050	1.937	1.625	1.234	1.047	.750	.875	1.453	1-1/2	1-5/16
16-DTBWE-16	1610-2-16W	16-1 ZELW2	1	1.315	1.937	1.844	1.234	1.047	.937	.875	1.453	1-1/2	1-5/16

*NOTE: All dimensions subject to change, to be used for reference only.

¹ The E dimension is the minimum opening. These fittings may have a larger opening at the pipe/straight thread end.

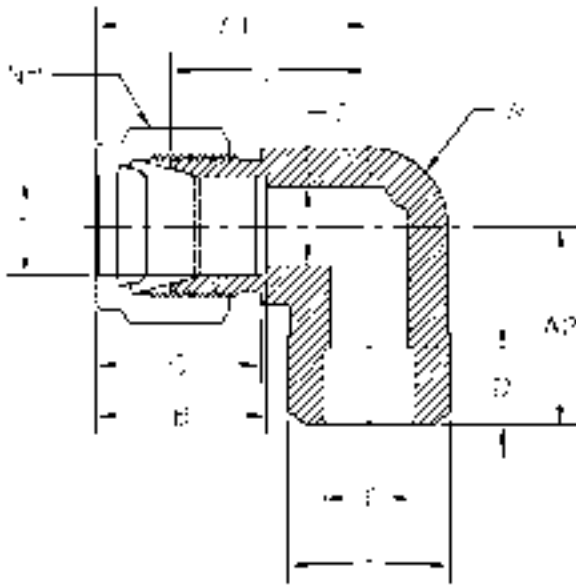

Tube to Socket Weld Elbow

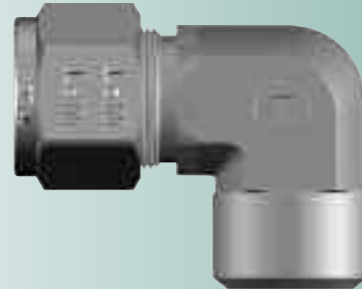

PART NUMBER	INTERCHANGES WITH	T TUBE O.D.	A1	A2	B	C	D	E THRU HOLE	F	L	NH NUT HEX	W WRENCH FLAT	
2-DTSWE-2	200-9-2W	2-2 ZELWZ	1/8	.922	.625	.516	.609	.156	.094	.375	.656	7/16	5/16
3-DTSWE-3	300-9-3W	3-3 ZELWZ	3/16	.984	.687	.547	.641	.203	.125	.437	.719	1/2	7/16
4-DTSWE-4	400-9-4W	4-4 ZELWZ	1/4	1.062	.766	.609	.703	.312	.187	.500	.766	9/16	1/2
6-DTSWE-6	600-9-6W	6-6 ZELWZ	3/8	1.203	.906	.656	.766	.375	.281	.625	.875	11/16	5/8
8-DTSWE-8	810-9-8W	8-8 ZELWZ	1/2	1.422	1.016	.906	.859	.500	.406	.812	1.016	7/8	13/16
10-DTSWE-10	1010-9-10W	10-10 ZELWZ	5/8	1.562	1.156	.969	.875	.500	.500	.937	1.156	1	1-1/16
12-DTSWE-12	1210-9-12W	12-12 ZELWZ	3/4	1.562	1.312	.969	.875	.500	.625	1.094	1.156	1-1/8	1-1/16
16-DTSWE-16	1610-9-16W	16-16 ZELWZ	1	1.937	1.469	1.234	1.047	.562	.875	1.375	1.453	1-1/2	1-5/16

*NOTE: All dimensions subject to change, to be used for reference only.

Female Run Tee

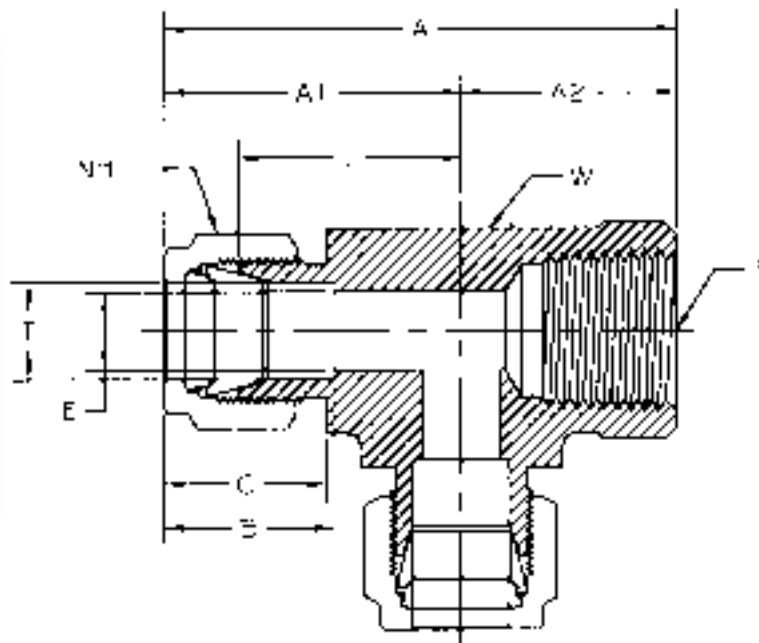
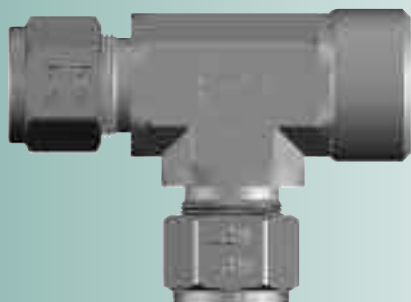

PART NUMBER	INTERCHANGES WITH	T TUBE O.D.	P PIPE END NPT	A	A1	A2	B	C	E THRU HOLE	L	NH NUT HEX	W WRENCH FLAT
2-DTFT-2	200-3TFT 2FRT2N	1/8	1/8	1.719	.969	.750	.500	.609	.094	.719	7/16	1/2
3-DTFT-2	300-3-2TFT 3FRT2N	3/16	1/8	1.766	1.016	.750	.547	.641	.125	.750	1/2	9/16
4-DTFT-2	400-3TFT 4FRT2N	1/4	1/8	1.812	1.078	.750	.609	.703	.187	.781	9/16	9/16
4-DTFT-4	400-3-4TFT 4FRT4N	1/4	1/4	2.047	1.172	.875	.609	.703	.187	.875	9/16	11/16
5-DTFT-2	500-3-2TFT 5FRT2N	5/16	1/8	1.922	1.172	.750	.641	.734	.250	.875	5/8	5/8
6-DTFT-4	600-3TFT 6FRT4N	3/8	1/4	2.109	1.234	.875	.656	.766	.281	.937	11/16	11/16
8-DTFT-4	810-3-4TFT 8FRT4N	1/2	1/4	2.562	1.437	1.125	.906	.875	.406	1.125	7/8	13/16
8-DTFT-6	810-3TFT 8FRT6N	1/2	3/8	2.297	1.422	.875	.906	.859	.406	1.016	7/8	13/16
8-DTFT-8	810-3-8TFT 8FRT8N	1/2	1/2	2.687	1.578	1.125	.906	.859	.406	1.172	7/8	1-1/16
10-DTFT-8	1010-3-8TFT 10FRT8N	5/8	1/2	2.656	1.531	1.125	.969	.875	.500	1.125	1	1-1/16
12-DTFT-12	1210-3TFT 12FRT12N	3/4	3/4	3.016	1.766	1.250	.969	.859	.625	1.359	1-1/8	1-3/8
14-DTFT-12	1410-3-12TFT 14FRT12N	7/8	3/4	3.016	1.766	1.250	1.031	.875	.750	1.359	1-1/4	1-5/16
16-DTFT-12	1610-3-12TFT 16FRT12N	1	3/4	3.187	1.937	1.250	1.234	1.047	.875	1.453	1-1/2	1-5/16
16-DTFT-16	1610-3TFT 16FRT16N	1	1	3.516	2.016	1.500	1.234	1.047	.875	1.531	1-1/2	1-5/8

*NOTE: All dimensions subject to change, to be used for reference only.

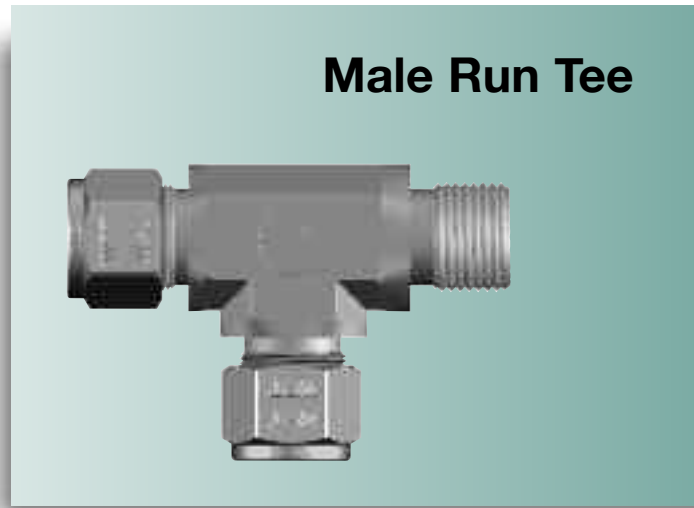
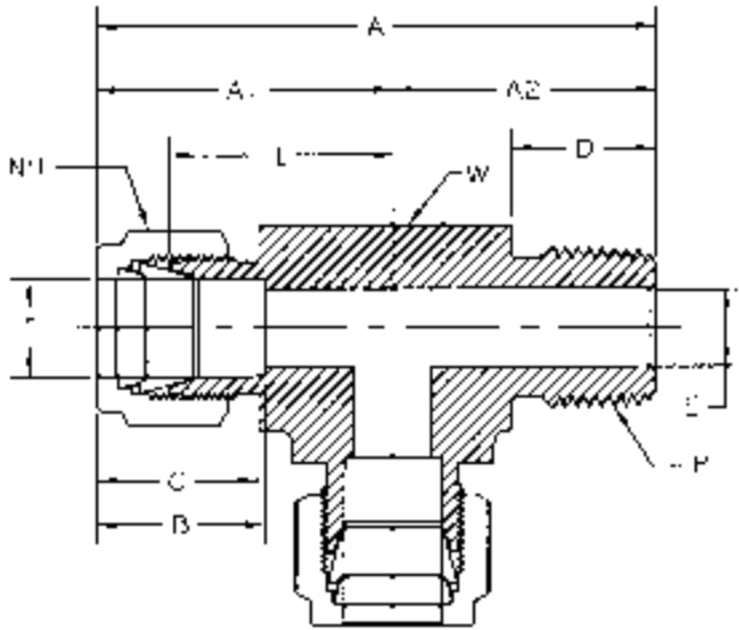

Male Run Tee

PART NUMBER	INTERCHANGES WITH	T TUBE O.D.	P PIPE END NPT	A	A1	A2	B	C	D	E ¹ THRU HOLE	L	NH NUT HEX	W WRENCH FLAT	
2-DTMT-2	200-3TMT	2MRT2N	1/8	1/8	1.625	.937	.703	.500	.609	.375	.094	.672	7/16	7/16
3-DTMT-2	300-3TMT	3MRT2N	3/16	1/8	1.656	.969	.703	.547	.625	.375	.125	.703	1/2	7/16
4-DTMT-2	400-3TMT	4MRT2N	1/4	1/8	1.797	1.062	.734	.609	.703	.375	.187	.766	9/16	1/2
4-DTMT-4	400-3-4TMT	4MRT4N	1/4	1/4	1.984	1.062	.922	.609	.703	.562	.187	.766	9/16	5/8
5-DTMT-2	500-3TMT	5MRT2N	5/16	1/8	1.984	1.172	.828	.641	.725	.375	.187	.875	5/8	5/8
6-DTMT-4	600-3TMT	6MRT4N	3/8	1/4	2.203	1.203	1.000	.656	.766	.562	.281	.906	11/16	5/8
6-DTMT-6	600-3-6TMT	6MRT6N	3/8	3/8	2.422	1.312	1.109	.656	.766	.562	.281	1.016	11/16	13/16
8-DTMT-6	810-3TMT	8MRT6N	1/2	3/8	2.531	1.422	1.109	.906	.859	.562	.406	1.016	7/8	13/16
8-DTMT-8	810-3-8TMT	8MRT8N	1/2	1/2	2.719	1.422	1.297	.906	.859	.750	.406	1.016	7/8	13/16
10-DTMT-8	1010-3TMT	10MRT8N	5/8	1/2	2.875	1.500	1.375	.969	.859	.750	.469	1.109	1	15/16
12-DTMT-12	1210-3TMT	12MRT12N	3/4	3/4	3.016	1.578	1.453	.969	.859	.750	.625	1.172	1-1/8	1-1/16
14-DTMT-12	1410-3-12TMT	14MRT12N	7/8	3/4	3.266	1.766	1.500	1.031	.875	.750	.750	1.359	1-1/4	1-5/16
16-DTMT-12	1610-3-12TMT	16MRT12N	1	3/4	3.609	1.937	1.656	1.234	1.047	.750	.875	1.453	1-1/2	1-5/16
16-DTMT-16	1610-3-16TMT	16MRT16N	1	1	3.781	1.937	1.844	1.234	1.047	.937	.875	1.453	1-1/2	1-5/16

*NOTE: All dimensions subject to change, to be used for reference only.

¹ The E dimension is the minimum opening. These fittings may have a larger opening at the pipe/straight thread end.

Female Branch Tee

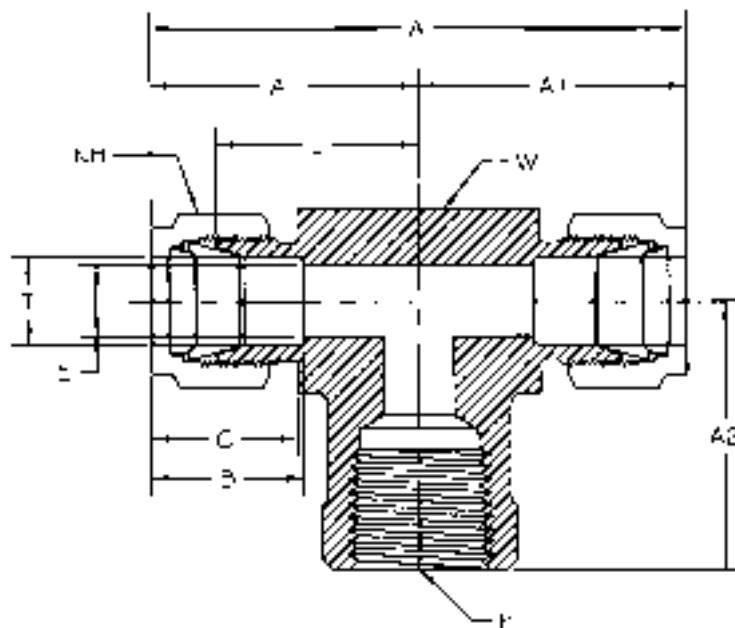

PART NUMBER	INTERCHANGES WITH	T TUBE O.D.	P PIPE END NPT	A	A1	A2	B	C	E THRU HOLE	L	NH NUT HEX	W WRENCH FLAT	
2-DTTF-2	200-3TTF	2FBT2N	1/8	1/8	1.937	.969	.750	.500	.609	.094	.719	7/16	1/2
3-DTTF-2	300-3-2TTF	3FBT2N	3/16	1/8	2.016	1.016	.750	.547	.641	.125	.750	1/2	1/2
4-DTTF-2	400-3TTF	4FBT2N	1/4	1/8	2.125	1.062	.750	.609	.703	.187	.766	9/16	1/2
4-DTTF-4	400-3-4TTF	4FBT4N	1/4	1/4	2.344	1.172	.875	.609	.703	.187	.875	9/16	11/16
5-DTTF-2	500-3-2TTF	5FBT2N	5/16	1/8	2.344	1.172	.750	.641	.734	.250	.875	5/8	5/8
6-DTTF-4	600-3TTF	6FBT4N	3/8	1/4	2.469	1.234	.875	.656	.766	.281	.937	11/16	11/16
8-DTTF-4	810-3-4TTF	8FBT4N	1/2	1/4	2.844	1.422	.875	.906	.859	.406	1.016	7/8	13/16
8-DTTF-6	810-3TTF	8FBT6N	1/2	3/8	2.844	1.422	.875	.906	.859	.406	1.016	7/8	13/16
8-DTTF-8	810-3-8TTF	8FBT8N	1/2	1/2	3.062	1.531	1.125	.906	.859	.406	1.125	7/8	1
10-DTTF-8	1010-3TTF	10FBT8N	5/8	1/2	3.062	1.531	1.125	.969	.859	.500	1.125	1	1
12-DTTF-12	1210-3TTF	12FBT12N	3/4	3/4	3.516	1.766	1.250	.969	.859	.625	1.359	1-1/8	1-3/8
14-DTTF-12	1410-3-12TTF	14FBT12N	7/8	3/4	3.016	1.766	1.250	1.031	.875	.750	1.359	1-1/4	1-5/16
16-DTTF-12	1610-3-12TTF	16FBT12N	1	3/4	3.859	1.937	1.250	1.234	1.047	.875	1.453	1-1/2	1-3/8
16-DTTF-16	1610-3TTF	16FBT16N	1	1	3.969	1.984	1.500	1.234	1.047	.875	1.500	1-1/2	1-11/16

*NOTE: All dimensions subject to change, to be used for reference only.

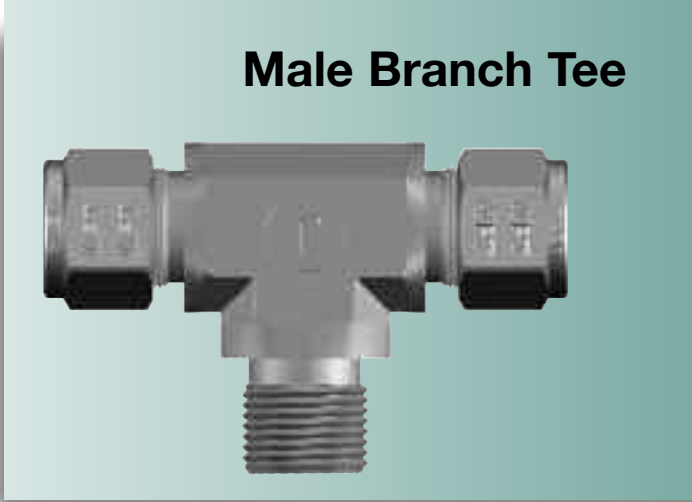
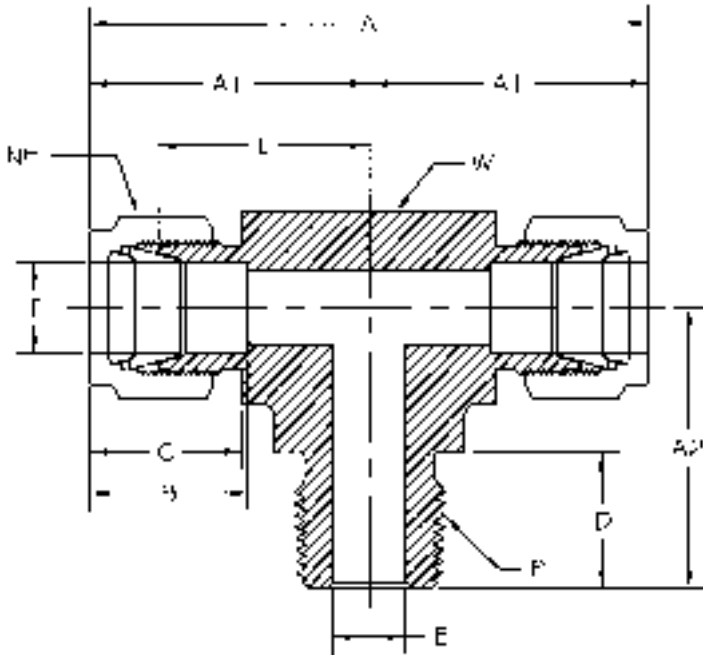

Male Branch Tee

PART NUMBER	INTERCHANGES WITH	T TUBE O.D.	P PIPE END NPT	A	A1	A2	B	C	D	E ¹ THRU HOLE	L	NH NUT HEX	W WRENCH FLAT	
2-DTTM-2	200-3TTM	2MBT2N	1/8	1/8	1.859	.937	.703	.500	.609	.375	.094	.672	7/16	7/16
2-DTTM-4	200-3-4TTM	2MBT4N	1/8	1/4	1.937	.969	.922	.500	.609	.562	.094	.719	7/16	1/2
3-DTTM-2	300-3TTM	3MBT2N	3/16	1/8	1.922	.969	.703	.547	.625	.375	.125	.703	1/2	7/16
4-DTTM-2	400-3TTM	4MBT2N	1/4	1/8	2.125	1.062	.734	.609	.703	.375	.187	.765	9/16	1/2
4-DTTM-4	400-3-4TTM	4MBT4N	1/4	1/4	2.125	1.062	.922	.609	.703	.562	.187	.765	9/16	1/2
5-DTTM-2	500-3TTM	5MBT2N	5/16	1/8	2.344	1.172	.828	.641	.725	.375	.187	.875	5/8	5/8
6-DTTM-4	600-3TTM	6MBT4N	3/8	1/4	2.406	1.203	1.000	.656	.765	.562	.281	.906	11/16	5/8
6-DTTM-6	600-3-6TTM	6MBT6N	3/8	3/8	2.625	1.312	1.109	.656	.765	.562	.281	1.016	11/16	13/16
8-DTTM-6	810-3TTM	8MBT6N	1/2	3/8	2.844	1.422	1.109	.906	.859	.562	.375	1.016	7/8	13/16
8-DTTM-8	810-3-8TTM	8MBT8N	1/2	1/2	2.844	1.422	1.297	.906	.859	.750	.406	1.016	7/8	13/16
10-DTTM-8	1010-3TTM	10MBT8N	5/8	1/2	3.062	1.531	1.406	.969	.859	.750	.469	1.125	1	1
12-DTTM-12	1210-3TTM	12MBT12N	3/4	3/4	3.141	1.172	1.453	.969	.859	.750	.625	1.172	1-1/8	1-1/16
14-DTTM-12	1410-3-12TTM	14MBT12N	7/8	3/4	3.516	1.766	1.500	1.031	.875	.750	.750	1.359	1-1/4	1-3/8
16-DTTM-12	1610-3-12TTM	16MBT12N	1	3/4	3.875	1.937	1.656	1.234	1.047	.750	.875	1.453	1-1/2	1-1/2
16-DTTM-16	1610-3-16TTM	16MBT16N	1	1	3.875	1.937	1.656	1.234	1.047	.937	.875	1.453	1-1/2	1-5/16

*NOTE: All dimensions subject to change, to be used for reference only.

¹ The E dimension is the minimum opening. These fittings may have a larger opening at the pipe/straight thread end.

Union Tee

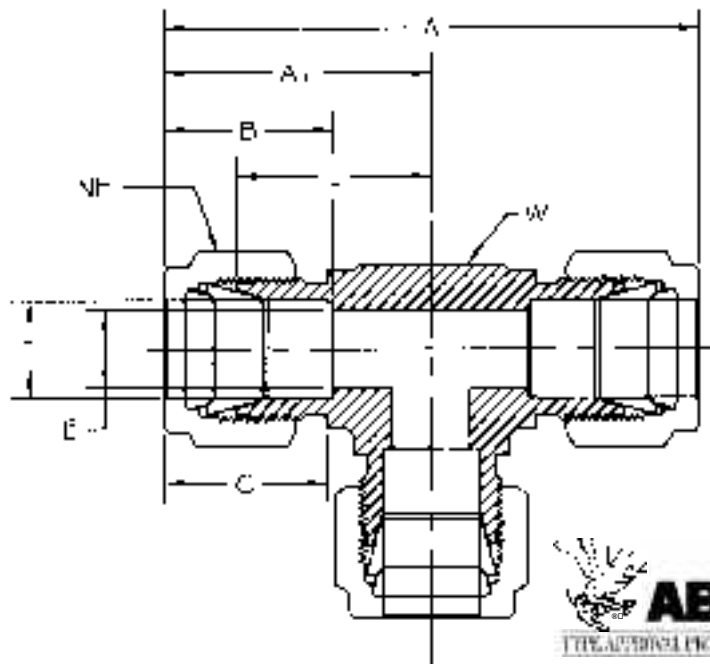
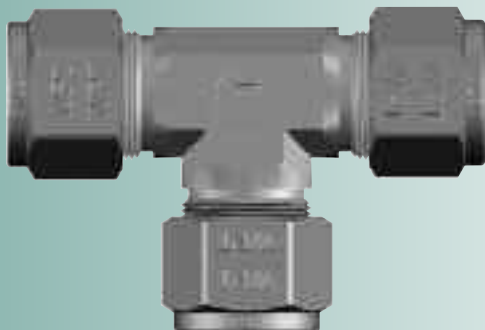

PART NUMBER	INTERCHANGES WITH	T TUBE O.D.	A	A1	B	C	E THRU HOLE	L	NH NUT HEX	W WRENCH FLAT	
1-DTTT-1	100-3	1ET1	1/16	1.406	.703	.344	.437	.052	.547	5/16	3/8
2-DTTT-2	200-3	2ET2	1/8	1.766	.875	.500	.609	.094	.625	7/16	3/8
3-DTTT-3	300-3	3ET3	3/16	1.922	.969	.547	.625	.125	.703	1/2	7/16
4-DTTT-4	400-3	4ET4	1/4	2.125	1.062	.609	.703	.187	.766	9/16	1/2
5-DTTT-5	500-3	5ET5	5/16	2.344	1.172	.641	.734	.250	.875	5/8	5/8
6-DTTT-6	600-3	6ET6	3/8	2.406	1.203	.656	.766	.281	.906	11/16	5/8
8-DTTT-8	810-3	8ET8	1/2	2.844	1.422	.906	.859	.406	1.016	7/8	13/16
10-DTTT-10	1010-3	10ET10	5/8	3.062	1.531	.969	.859	.500	1.125	1	1
12-DTTT-12	1210-3	12ET12	3/4	3.141	1.578	.969	.859	.625	1.172	1-1/8	1-1/16
14-DTTT-14	1410-3	14ET14	7/8	3.516	1.766	1.016	.859	.718	1.359	1-1/4	1-3/8
16-DTTT-16	1610-3	16ET16	1	3.859	1.937	1.234	1.047	.875	1.453	1-1/2	1-3/8

*NOTE: All dimensions subject to change, to be used for reference only.

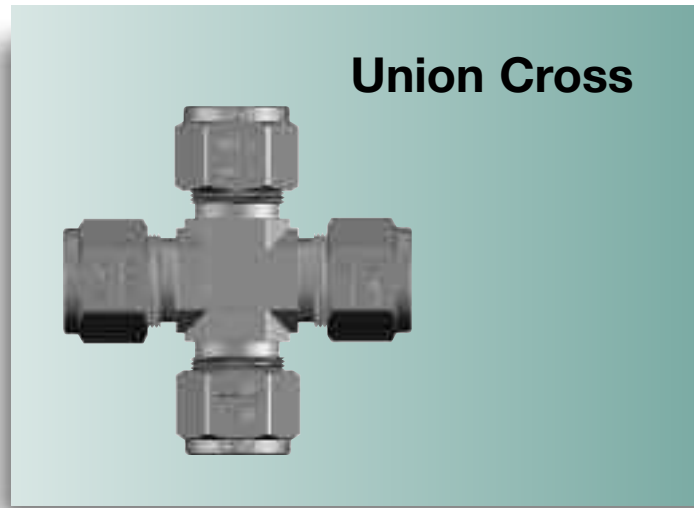
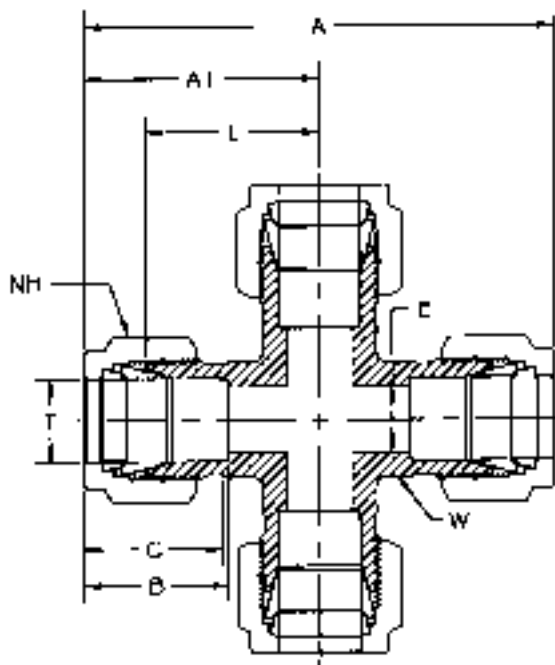

PART NUMBER	INTERCHANGES WITH	T TUBE O.D.	A	A1	B	C	E THRU HOLE	L	NH NUT HEX	W WRENCH FLAT
2-DCR	200-4 2ECR2	1/8	1.766	.875	.500	.609	.094	.625	7/16	3/8
4-DCR	400-4 4ECR4	1/4	2.125	1.062	.609	.703	.187	.766	9/16	1/2
5-DCR	500-4 5ECR5	5/16	2.344	1.172	.641	.734	.250	.875	5/8	5/8
6-DCR	600-4 6ECR6	3/8	2.406	1.203	.656	.766	.281	.906	11/16	5/8
8-DCR	810-4 8ECR8	1/2	2.844	1.422	.906	.859	.406	1.016	7/8	13/16
12-DCR	1210-4 12ECR12	3/4	3.016	1.516	.969	.859	.625	1.109	1-1/8	1-1/16
16-DCR	1610-4 16ECR16	1	3.687	1.844	1.234	1.047	.875	1.359	1-1/2	1-3/8

*NOTE: All dimensions subject to change, to be used for reference only.

Barbed Insert

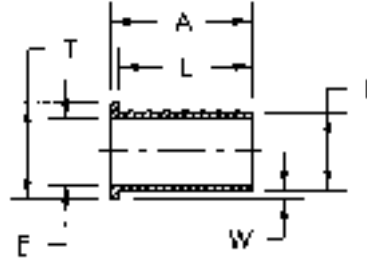
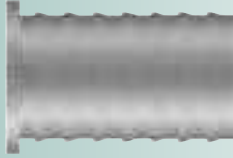

PART NUMBER	INTERCHANGES WITH	T TUBE O.D.	W REF.	A	E THRU HOLE	F TUBE I.D.	L
3-DBI-030	305-2	3/16	.031	.566	.062	1/8	.518
4-DBI-031	405-3	1/4	.031	.566	.125	3/16	.518
4-DBI-040	405-170	1/4	.040	.566	.109	11/64	.518
4-DBI-062	405-2	1/4	.062	.566	.062	1/8	.518
5-DBI-031	505-4	5/16	.031	.566	.187	1/4	.518
5-DBI-062	505-3	5/16	.062	.566	.125	3/16	.518
5-DBI-094	505-2	5/16	.094	.566	.062	1/8	.518
6-DBI-062	605-4	3/8	.062	.566	.187	1/4	.518
6-DBI-094	605-3	3/8	.094	.566	.125	3/16	.518
8-DBI-062	815-6	1/2	.062	.750	.312	3/8	.702
8-DBI-125	815-4	1/2	.125	.750	.187	1/4	.702
10-DBI-062	1015-8	5/8	.062	.750	.437	1/2	.702
10-DBI-125	1015-6	5/8	.125	.750	.312	3/8	.702
12-DBI-062	1215-10	3/4	.062	.750	.562	5/8	.702
12-DBI-125	1215-8	3/4	.125	.750	.437	1/2	.702
16-DBI-125	1615-12	1	.125	1.031	.687	3/4	.938

*NOTE: All dimensions subject to change, to be used for reference only.

Plain Insert

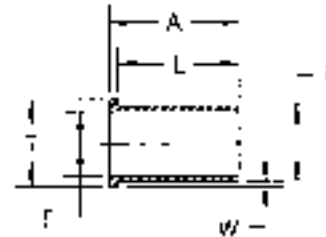
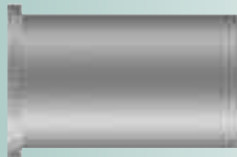

PART NUMBER	INTERCHANGES WITH	T TUBE O.D.	W REF.	A	E THRU HOLE	F TUBE I.D.	L
3-DPI-030	3 TIZ (.125)	3/16	.031	.566	.062	1/8	.518
4-DPI-031	4 TIZ (.188)	1/4	.031	.566	.125	3/16	.518
4-DPI-040	4 TIZ (.170)	1/4	.040	.566	.109	11/64	.518
4-DPI-062	4 TIZ (.125)	1/4	.062	.566	.094	1/8	.518
5-DPI-031	5 TIZ (.250)	5/16	.031	.566	.188	1/4	.518
5-DPI-062	5 TIZ (.188)	5/16	.062	.566	.125	3/16	.518
5-DPI-094	5 TIZ (.125)	5/16	.094	.566	.062	1/8	.518
6-DPI-062	6 TIZ (.250)	3/8	.062	.566	.187	1/4	.518
6-DPI-094	6 TIZ (.188)	3/8	.094	.566	.125	3/16	.518
8-DPI-062	8 TIZ (.375)	1/2	.062	.750	.312	3/8	.702
8-DPI-125	8 TIZ (.250)	1/2	.125	.750	.187	1/4	.702
10-DPI-062	10 TIZ (.500)	5/8	.062	.750	.437	1/2	.702
10-DPI-125	10 TIZ (.375)	5/8	.125	.750	.312	3/8	.702
12-DPI-062	12 TIZ (.625)	3/4	.062	.750	.562	5/8	.702
12-DPI-125	12 TIZ (.500)	3/4	.125	.750	.437	1/2	.702
16-DPI-125	16 TIZ (.750)	1	.125	1.000	.687	3/4	.952

*NOTE: All dimensions subject to change, to be used for reference only.

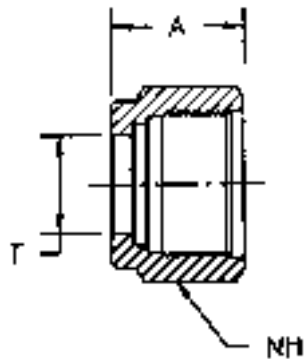

Nut

PART NUMBER	INTERCHANGES WITH	T TUBE O.D.	A	NH NUT HEX
DN-1	102-1 1NU1	1/16	.312	5/16
DN-2	202-1 2NU2	1/8	.469	7/16
DN-3	302-1 3NU3	3/16	.469	1/2
DN-4	402-1 4NU4	1/4	.500	9/16
DN-5	502-1 5NU5	5/16	.531	5/8
DN-6	602-1 6NU6	3/8	.562	11/16
DN-8	812-1 8NU8	1/2	.687	7/8
DN-10	1012-1 10NU10	5/8	.687	1
DN-12	1212-1 12NU12	3/4	.687	1-1/8
DN-14	1412-1 14NU14	7/8	.687	1-1/4
DN-16	1612-1 16NU16	1	.812	1-1/2

*NOTE: All dimensions subject to change, to be used for reference only.

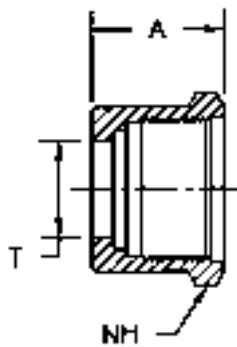

Knurled Nut

The knurled nut is used with fittings where applications of a finger tight assembly is acceptable. Common applications include, but are not limited to, low pressure laboratory use on plastic tubing.

Knurled nuts are available in the same sizes as shown for CBC-Lok® nuts (DN). The knurled nut part descriptor is DKN. For example, the part number for a 1/2" knurled nut is SS-DKN-8.

COLLETS

DFC/DRC/DCSET/DNCSET



**Front Collet
(Ferrule)**

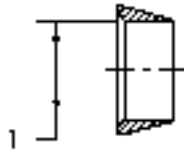

PART NUMBER	INTERCHANGES WITH	T TUBE O.D.
DFC-1	103-1 1FF1	1/16
DFC-2	203-1 2FF2	1/8
DFC-3	303-1 3FF3	3/16
DFC-4	403-1 4FF4	1/4
DFC-5	503-1 5FF5	5/16
DFC-6	603-1 6FF6	3/8
DFC-8	813-1 8FF8	1/2
DFC-10	1013-1 10FF10	5/8
DFC-12	1213-1 12FF12	3/4
DFC-14	1413-1 14FF14	7/8
DFC-16	1613-1 16FF16	1

*NOTE: All dimensions subject to change, to be used for reference only.



**Rear Collet
(Ferrule)**

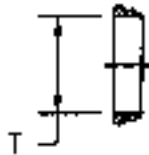

PART NUMBER	INTERCHANGES WITH	T TUBE O.D.
DRC-1	104-1 1BF1	1/16
DRC-2	204-1 2BF2	1/8
DRC-3	304-1 3BF3	3/16
DRC-4	404-1 4BF4	1/4
DRC-5	504-1 5BF5	5/16
DRC-6	604-1 6BF6	3/8
DRC-8	814-1 8BF8	1/2
DRC-10	1014-1 10BF10	5/8
DRC-12	1214-1 12BF12	3/4
DRC-14	1414-1 14BF14	7/8
DRC-16	1614-1 16BF16	1

*NOTE: All dimensions subject to change, to be used for reference only.

Component Replacement Parts

Collet sets and Nut/Collet sets make for easy storage and handling of nuts and collets. CBC-Lok® component parts are precision made and should be handled with care. The components can be ordered on an arbor, which aids in careful handling and prevents them from coming off. Pinch the end of the arbor to release the components.

Collet Sets



PART NUMBER	INTERCHANGES WITH	TUBE O.D.	QUANTITY (per arbor)
DCSET-4-10	400 Sets-10 4-ALOK-SS-SET	1/4	10
DCSET-6-10	600 Sets-10 6-ALOK-SS-SET	3/8	
DCSET-8-10	810 Sets-10 8-ALOK-SS-SET	1/2	
DCSET-12-10	1210 Sets-10 12-ALOK-SS-SET	3/4	
DCSET-16-10	1610 Sets-10 16-ALOK-SS-SET	1	

Nut/Collet Sets contain 5 nuts & 5 collets on an arbor.
1/2" Nut/Collet Set part number: SS-DNCSET-8-5

Nut/Collet Sets



PART NUMBER	TUBE O.D.	QUANTITY (per arbor)
DNCSET-4-5	1/4	5
DNCSET-6-5	3/8	
DNCSET-8-5	1/2	
DNCSET-12-5	3/4	
DNCSET-16-5	1	

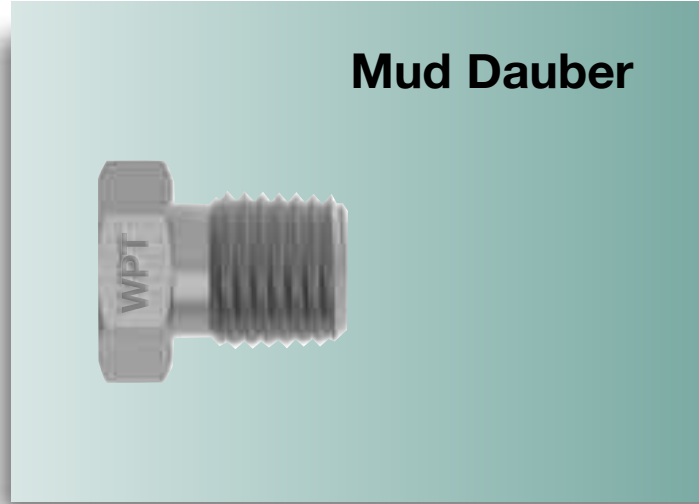
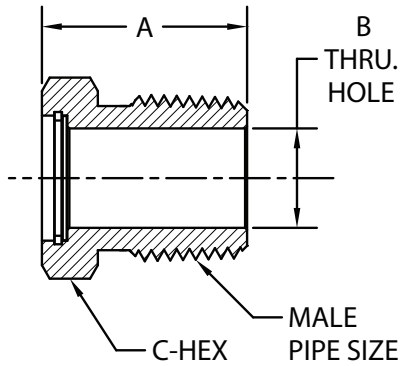

Mud Dauber

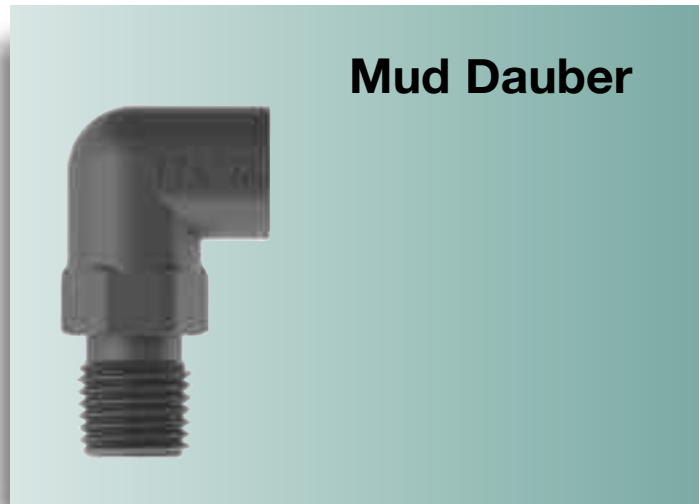
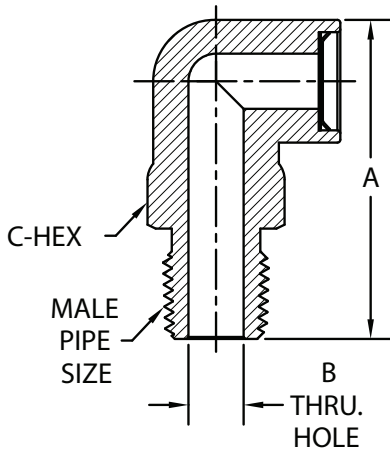

Mud Dauber

- Tylok Mud Daubers or Vent Protector fittings protect open ends of tubing, instruments, outlet vents and exhaust lines.
- Each Vent Protector has a 300 series stainless steel 40 mesh wire screen to prevent obstructive foreign objects, such as insects, from entering and clogging a system.
- Straight Vent Protectors are available in either Stainless Steel (SS) or Brass. *Add an SS or B in front of part number to specify the desired material*
- Angled Vent Protectors are available in Polypropylene (PP) only.

PART NUMBER	INTERCHANGES WITH	NPT SIZE	A OVERALL LENGTH	B THRU HOLE	C HEX
4-1MDF	MD-4 2 MDF	1/4-18	.81	.28	9/16
6-1MDF	MD-6 6 MDF	3/8-18	.81	.41	11/16
8-1MDF	MD-8 8 MDF	1/2-14	1.03	.50	7/8
PP-4-2MDF	- -	1/4-18	1.44	.28	5/8
PP-6-2MDF	- -	3/8-18	1.44	.28	11/16

*NOTE: All dimensions subject to change, to be used for reference only.

Thermocouple Bore Through

A Thermocouple Connector can be furnished already bored through for an additional charge. When ordering:

1. Select required size male connector. See pages 14 and 15 for a listing of available Male Connectors.
2. Add the letters "BT" to designate bore through. Example: 4-DMC-2-BT



Tylube™ Thread Lubricant

Tylube™ is an anti-gall compound to be used on stainless steel, steel and nickel based alloys. Temperature range to 500°F. Not recommended for plastic and aluminum products. Tylube™ is made from distilled water with inert ingredients and contains no silicones, heavy metals, chlorine or sulfur. Safe for oxygen-safe applications. For a complete list of ingredients, request an MSDS to be sure of its compatibility with your installation. Available in 8 oz. plastic bottles.



CBC-Lok® Installation Instructions

CBC-Lok® Tube Fittings come completely assembled and ready for use, no disassembly required. Although there are some general guide lines to follow, no special preparation of the tubing is necessary. (Reference page 48.) In overhead applications, Tylok recommends using a Pre-Set Tool. (See page 51.)

Size		Tighten # Turn(s)
1	1/16"	3/4
2	1/8"	
3	3/16"	
4	1/4"	1-1/4
5	5/16"	
6	3/8"	
8	1/2"	
10	5/8"	
12	3/4"	
14	7/8"	
16	1"	

Size #1 Thru #3
(1/16" – 3/16")

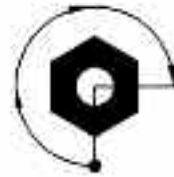

Finger Tight Plus
3/4 Turn

Size #4 Thru #16
(1/4" – 1")

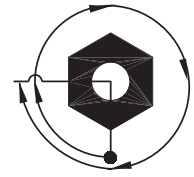

Finger Tight Plus
1-1/4 Turns



Simply insert the tubing into the assembly, making sure the tubing seats firmly against the shoulder of the body and the nut is finger tight. **High Pressure Applications and high safety-factor systems:**

Further tighten the nut until the tube will not turn by hand or move axially in the fitting.



Tighten nut with wrench the additional number of turns indicated above, while holding the fitting body with a second wrench.

To Remove Tube and Re-Connect Tube Fitting

Mark the location of the nut with reference to the body before disassembly. For reassembly, re-insert the tubing into the body until it is seated. With proper size wrench, retighten nut to original location by realigning previous marks. A noticeable amount of torque will develop when the nut is turned to original position. Next, rotate the nut slightly past original position to fully re-set the seal.



Mark the location of the nut with reference to the body.



Back off the nut until it is clear of the body and remove the tubing from the fitting.

CBC-Lok® Tubing Selection & Preparation

Proper selection of tubing is key to the performance of the fitting. When selecting the proper wall thickness and material, all tubing should be compatible with the process fluid, temperature, application, flow and system pressure.

For proper sealing it is recommended that the tubing and fitting be of like material to allow for positive sealing (i.e., stainless on stainless, brass on copper, steel on steel). Galvanic corrosion could occur if the tubing and fitting are not of like material, with the exception of a brass fitting on copper tubing.

When using stainless steel tubing, Tylok recommends using Type 304 or 316 fully annealed, seamless or welded redrawn meeting ASTM-A-213, ASTM-A-269 or equivalent, with a suggested maximum hardness of 80 Rb.

For copper tubing, Tylok suggests using soft annealed, seamless tubing per ASTM-B75 or equivalent. Copper water tube type K or L, soft annealed (Temper O) per ASTM-B88 can also be used.

When using carbon steel, all tubing should be fully annealed and conform to ASTM-A-179, or equivalent, with a maximum hardness of 72 Rb.

In general, all tubing should be free of nicks, scratches, or imperfections of any kind and should be suitable for bending. Out of round tubing that does not easily go through fitting components should not be used. It is recommended that the charts be used for tube selection. Ideally, the tube end should be cut square so that when it bottoms out inside the fitting, an extra seal is provided. Avoid installing contaminated tubing into your system. For elevated temperatures, see page 50.

CBC-Lok® Tube Fittings swage the tubing to achieve sealing. Thin wall tubing (wall thicknesses with working pressures highlighted in reverse text in the charts) is not recommended for Gas Service. For Gas Service, see page 49.

When using tubing of a thinner or thicker wall than shown, it is always recommended that you consult with your local Distributor or contact Tylok International directly if there is any doubt selecting tubing.

It is the responsibility of the Engineer to refer to the technical pages in this catalog to ensure selection of the proper tubing material, tubing compatibility with the fitting, media and tubing wall thickness.

Values in reverse text are not recommended for Gas Service.

Note: Tables, calculated to the right, are suggested maximum working pressure ratings, in accordance with ASME B31.3, but should be used for reference only. Tylok International, Inc., is not responsible for its accuracy nor designs using these figures. All compatible Tylok fittings will withstand pressures above those listed for maximum tubing working pressures.

Following the stated recommendations will result in a safe application, free of leaks. The entire system must be considered when selecting the tube. Tylok tube fittings are designed to work to the tubing pressure ratings found in the charts below.

SUGGESTED ALLOWABLE WORKING PRESSURE TABLES (psig)

Stainless Steel								
Tube Size O.D.	Tube Wall Thickness (inches)							
	.028	.035	.049	.065	.083	.095	.109	.120
1/8"	8400	10600						
3/16"	5500	7000	10100					
1/4"	4000	5100	7500	10100				
5/16"		4100	5900	8000				
3/8"		3300	4800	6600				
1/2"		2600	3800	5100	6700			
5/8"			3000	4000	5200	6100		
3/4"			2500	3300	4300	5000	5800	
7/8"			2100	2800	3600	4200	4900	
1"				2400	3200	3700	4200	4700

75,000 PSI Tensile

Note: For welded and drawn tubing, a derating factor must be utilized. For double welded tube, multiply the above pressure rating by .85; and for single welded tube by .80 (ANSI B 31, Table A-1B).

Carbon Steel								
Tube Size O.D.	Tube Wall Thickness (inches)							
	.028	.035	.049	.065	.083	.095	.109	.120
1/8"	8100	10200						
3/16"	5200	6700	9600					
1/4"	3800	4900	7100	9600				
5/16"		3800	5500	7600				
3/8"		3100	4500	6200				
1/2"		2300	3300	4500	6000			
5/8"			2600	3500	4600	5300		
3/4"			2200	2900	3800	4400	5100	
7/8"			1800	2500	3200	3700	4300	
1"				2100	2800	3200	3700	4200

47,000 PSI Tensile

Copper								
Tube Size O.D.	Tube Wall Thickness (inches)							
	.028	.035	.049	.065	.083	.095	.109	.120
1/8"	2700	3600						
3/16"	1800	2300	3500					
1/4"	1300	1700	2500	3600				
5/16"		1300	2000	2800				
3/8"		1100	1600	2300				
1/2"		800	1200	1700	2200			
5/8"			900	1300	1700	1900		
3/4"			800	1000	1400	1600	1900	
7/8"			600	900	1100	1300	1600	
1"			500	800	1000	1200	1400	1500

30,000 PSI Tensile

Gas Service

Extra care must be taken when tubing is used in gas service applications. Small gas molecules easily escape through minute leak paths; therefore, the tubing must be free of nicks, scratches and imperfections of any kind. When using large diameter tubing the possibility of surface defects is increased further due to greater surface area. It is strongly recommended that the heavier wall thicknesses be selected. Penetration of the ferrules on thin wall tubing or soft material may not offer enough radial resistance for sealing.

Values in reverse text are not recommended for Gas Service.

Gap Gage

Gap Gages can be purchased to ensure the Installer and Inspector that the nut has been properly tightened.



Part Number	Tube Size	Part Number	Tube Size
#1-DGG	1/16"	#10-DGG	5/8"
#2-DGG	1/8"	#12-DGG	3/4"
#3-DGG	3/16"	#14-DGG	7/8"
#4-DGG	1/4"	#16-DGG	1"
#5-DGG	5/16"	#468-DGG	1/4", 3/8", 1/2"
#6-DGG	3/8"		6mm, 12mm
#8-DGG	1/2"		



When fitting is properly tightened, **gap gage should not fit** between nut and shoulder of body.

Precautions for Weld Ends

CBC-Lok® Tube Fittings with weld ends offer the same positive sealing as all other Tylok fittings. Welding could deform the assembly, making pull ups or disassembly difficult. Some precautions should be taken...

- Remove the nut and ferrules from the fitting
- It is important that the fitting threads and sealing surfaces be protected from weld splatter
- A heat sink should be used to dissipate heat
- Ensure alignment by tack welding symmetrically
- Once welded, remove the weld splatter protection and reassemble nut and ferrules on fitting

Safety Guidelines

- Never connect, disconnect or remake a fitting with pressure in the system
- Make sure all fittings are properly installed, reference Installation Instructions - page 47, before pressurizing the system
- Tubing material should be softer than fitting material
- Tylok recommends using only Tylok replacement parts
- Although the fittings will hold to the pressure rating of the tubing, it is not recommended to go beyond this rating. Elongation could occur in the tubing, shrinking the wall thickness and causing potential harm to anyone in the area
- Always use proper thread lubricants and sealants on tapered pipe threads
- If process fluids are toxic and/or hazardous, exercise extra caution
- Never bleed a system by loosening a fitting
- For proper sealing it is recommended that the tubing and fitting be of like material

Quality Control

All components are manufactured and inspected to meet strict quality control standards in each phase of production. All employees are thoroughly trained to follow procedures, in accordance with the ISO 9001:2008 Quality Standard, to ensure a quality product from the start of each job through completion.

Pipe Thread Specifications

Tylok Pipe Fittings are manufactured from materials meeting applicable ASTM or ASME specifications, with pipe threads which meet or exceed ANSI B1.20.1 requirements. Strict quality control procedures are followed throughout production. All parts are individually inspected to provide the finest possible product.

Materials: Brass ■ 316 Stainless Steel ■ Steel

Suggested Maximum Operating Pressures for Male Pipe Threads

MNPT Size	316 Stainless Steel PSI Rating	Brass PSI Rating	Steel PSI Rating
1/16"	10,100	5,700	10,500
1/8"	9,200	5,300	9,800
1/4"	7,500	4,100	8,000
3/8"	7,250	4,000	7,700
1/2"	6,900	3,900	7,300
3/4"	6,600	3,700	7,000
1"	5,000	2,700	5,000

Suggested Maximum Operating Pressures for Female Pipe Threads

FNPT Size	316 Stainless Steel PSI Rating	Brass PSI Rating	Steel PSI Rating
1/16"	6,200	3,500	6,800
1/8"	6,000	3,400	6,600
1/4"	6,100	3,300	6,500
3/8"	5,000	2,700	5,400
1/2"	4,700	2,500	4,800
3/4"	4,300	2,400	4,600
1"	4,100	2,300	4,500

These charts are to be used as a guide only and are based on normal wall thicknesses, used for the various sizes. These ratings may vary widely from effects such as the proper use of sealants, size of stock, temperature, corrosion factors, etc. Therefore, Tylok International, Inc., assumes no responsibility for its accuracy in any individual design.

Temperature Ratings

Tylok Instrumentation Fittings are rated at the following temperatures:

316 Stainless	-325°F to 1200°F (-198°C to 648°C)	Brass	-40°F to 400°F (-40°C to 204°C)	Steel	-65°F to 400°F (-54°C to 204°C)
---------------	---------------------------------------	-------	------------------------------------	-------	------------------------------------

Note: Consideration should be given to maximum temperature ratings if fittings and/or tubing are coated or plated.

Tube Pressure Derating Factors at Elevated Temperatures

The following table lists derating factors that must be considered in applications above that of ambient temperatures.

Temperatures		Multiplier Factors			
°F	°C	304 SS	316 SS	Copper	Carbon Steel
200	93	1.00	1.00	.80	.95
400	204	.94	.97	.50	.86
600	315	.82	.85		.77
800	427	.76	.80		.59
1000	538	.69	.77		

These charts are to be used as a guide only and are based on normal wall thicknesses, used for the various sizes. These ratings may vary widely from effects such as the proper use of sealants, size of stock, temperature, corrosion factors, etc. Therefore, Tylok International, Inc., assumes no responsibility for its accuracy in any individual design.

Example

Type 316 Stainless Steel 1/4" O.D. x .049" wall at 800°F is:

$$7,500 \text{ PSI} \times .80 = \underline{6,000 \text{ PSI}}$$

Therefore, the suggested allowable working pressure for 316 Stainless Steel (1/4" O.D. with .049" tube wall) at 800°F is 6,000 PSI.

Heat Traceability

CBC-Lok® Tube Fittings are completely heat code traceable back to the original mill heat from which they were made. Starting with the original billet, the mill creates a certificate that completely describes the chemical and physical makeup. For any one of the four components (body, front ferrule, rear ferrule, nut), the material certifications can be provided. Call Tylok and provide the heat code stamp marked on the part itself, along with the part number to obtain the certificate.

Raw Material Specifications

Fitting Material	Bar Stock	Forging	*Tubing Specification	Maximum Specification Hardness (Tubing)
Brass	ASTM-B16 Alloy 360 ASTM-B453 Alloy 345	ASTM-B124 Alloy 377	ASTM-B75 Copper (Temper O)	60 Max. Rockwell 15T
Stainless Steel	ASTM-A276 ASME-SA-479 Type 316-SS	ASME-SA-182 Type 316-SS	ASTM-A213 ASTM-A269	90 Rb
Steel	ASTM-A108		ASTM-A179	72 Rb

*Reference Tubing Selection & Preparation, page 44.

Tylok Pre-Setting Tool

The CBC-Lok® product line offers a Pre-Setting Tool when fittings need to be installed in hard to reach places. The Pre-Setting Tool is designed to be used in any tabletop vise. After tightening the nut the specified number of turns, as stated in the included installation instructions, loosen the nut from the Pre-Setting Tool. Once the ferrules have swaged into the tubing surface, the assembly is ready for installation.

When ordering the CBC-Lok® Pre-Set Tool, reference the part number in the chart. The Pre-Set Tool is hardened for maximum durability. The Pre-Set Tool can be used repeatedly to set the ferrules onto the tubing for easy installation.



Part Number	Tube Size
#1-DPST	1/16"
#2-DPST	1/8"
#3-DPST	3/16"
#4-DPST	1/4"
#5-DPST	5/16"
#6-DPST	3/8"
#8-DPST	1/2"
#10-DPST	5/8"
#12-DPST	3/4"
#14-DPST	7/8"
#16-DPST	1"



Place Pre-Setting Tool in a vice and tighten nut specified number of turns.



Back nut off of Pre-Setting Tool. Notice the ferrules have swaged into the tubing. Now take tubing to installation area.

Tube Insertion Chart

For pre-cutting tubing to length, the following chart shows the additional length inside the fitting assembly.

Tube
Insertion
Depth
Finger Tight

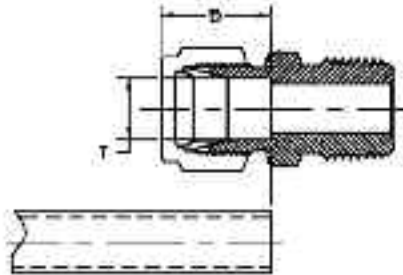

Tube Size	T Tube O.D.	B Dimension
#1	1/16	.34
#2	1/8	.50
#3	3/16	.54
#4	1/4	.60
#5	5/16	.64
#6	3/8	.66
#8	1/2	.90
#10	5/8	.96
#12	3/4	.96
#14	7/8	1.02
#16	1.0	1.23

*NOTE: All Dimensions Subject to Change.

Tubing-General Applications

CBC-Lok® Tube Fittings are designed to perform in a variety of applications that demand high performance. The CBC-Lok® product line has been engineered to provide optimal performance. However, tubing should always be considered as an important factor in the design stages of any system. Below is a table that describes some general uses for different types of materials. The table is provided as a reference to the Engineer in the design process.

Tylok suggests the use of seamless, fully annealed tubing. Welded tubing may be used with Tylok fittings. However, due to the manufacturing of welded tubing, variables may be encountered. The media flowing through the tubing must be compatible with the tubing itself. It is always a good rule to use like tubing material on like fitting material. If this format is not followed, the ferrules may have difficulty penetrating the tubing, adversely affecting the sealing ability. In addition, dissimilar materials in contact may be sensitive to galvanic corrosion. Tylok recommends ordering tubing material to meet ASTM specifications to ensure that it will be dimensionally, physically and chemically within precise limits. (See Raw Material Specifications chart on page 51.)

Tubing Material	General Applications	Recommended Temperature Range
Carbon Steel	Air Lines, High Pressure, High Temperature, Oil, Air, Specialty Chemicals, Hydraulic Gases	-20°F to 400°F*
Copper	Low Temperature, Low Pressure Water, Oil, Air, Pneumatic Controls, Lube Lines	-40°F to 400°F
Stainless Steel	High Pressure, High Temperature, Nitrogen, Helium, Flammable Gases, Hydraulic, Gases, generally corrosive media	-20°F to 1000°F

*Based on 400°F maximum.

Notice

In designing a system incorporating tube fittings and valves, it is the designer's or user's obligation and responsibility to determine the appropriate fittings and valves to be used for each application and to insure proper installation and maintenance.

Limited Warranty

Tylok fittings and valves are warranted solely against defects in material and workmanship in the performance of the specific functions for which they are designed, as set forth in the published specifications, for a period of 12 months. Should any fitting and valve or its component fail due to a defect in material or workmanship, Tylok will replace said fitting and valve without charge upon return of the failed part and evidence of its failure being due to materials or workmanship.

The Warranty above set forth is the only warranty applicable to Tylok products, and is in lieu of any and all other warranties either express or implied, including any warranty of merchantability or fitness. Tylok's sole responsibility or liability as a result of any loss or damage due to failure shall be to replace the failed part or fitting and valve, and it shall bear no liability for any incidental or consequential damages to person or property.

Tylok Liquid Leak Detectors

TySpy and Cool TySpy liquid leak detectors detect gas leaks in hard-to-reach areas

- Safe for oxygen systems
- Sustained bubble action works even on very small leaks and vertical surfaces
- Flexible tube extends for hard-to-reach areas
- Formula dries clean, without staining

Part Number	Container Size	Pull Out Tube Length
TYPSY-8oz	8 fl oz. (236ml)	12 inch (30.48cm)
TYSPY-Gal	1 Gallon	
COOL TYSPY-8oz	8 fl oz. (236ml)	12 inch (30.48cm)
COOL TYSPY-Gal	1 Gallon	



TYSPY LIQUID LEAK DETECTOR

- **Temperature rating:** Can be used over a temperature range of 27 to 200°F (-2 to 93°C)

Specifications: Meets the performance requirement of:

- MIL-PRF-25567 Leak Detector Compound, Oxygen Systems, Type I, 1 to 70°C (33 to 158°F)
- NFPA 52 Section 6-12.2 Leak Testing Compressed Natural Gas Vehicular Fuel System
- EPA Part 60, Appendix A, Method 21, Section 4.3.3 Alternative Screening Procedures Using Soap Solutions
- Nontoxic, noncorrosive, nonflammable

COOL TYSPY LIQUID LEAK DETECTOR

- **Temperature rating:** Can be used over a temperature range of -65 to 200F (-54 to 93° C)

Specifications: Meets the performance requirement of:

- MIL-PRF-25567 Leak Detector Compound, Oxygen Systems, Type II, -54 to 1°C (-65 to 33°F)
- NFPA 52 Section 6-12.2 Leak Testing Compressed Natural Gas Vehicular Fuel System
- EPA Part 60, Appendix A, Method 21, Section 4.3.3 Alternative Screening Procedures Using Soap Solutions
- Noncorrosive, nonflammable





Instrumentation Tube Fittings

CBC-Lok®

CS-Lok®

Tylok Standard

Pipe Fittings

Weld Fittings

Ball Valves

Ty-Flo® HP Series

Ty-Flo® 3 Piece

Needle Valves

Plug Valves

Quick Connects

Flexible Metal Hose



1061 East 260th Street • Euclid, Ohio 44132
[T] 216.261.7310 • 800.321.0466 • [F] 216.261.7317
info@tylok.com • www.tylok.com

CBC-Lok Tube Fittings Catalog Doc. 72305 Rev. K

©2013 Tylok International, Inc. • All rights reserved • Litho in U.S.A.