



**Catalog**

Worldwide Innovator in Branch Connections

**24 Hour Emergency Service**

1341 Hill Road • Houston, TX 77039 • Toll Free: (888) 610-0777 • Phone: (281) 590-0190 • Fax: (281) 590-1415

[www.woihouston.com](http://www.woihouston.com)



**ISO 9001:2008  
PED Certified  
Canadian Registered**

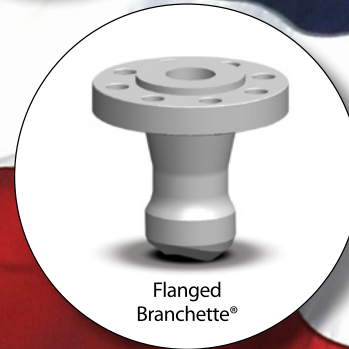

## Basic Design Specifications

- B1.20.1: Pipe Threads
- B16.5: Pipe Flanges & Flanged Fittings
- B16.9: Butt-Weld Fittings
- B16.11: Socket-Weld & Threaded Fittings
- B16.25: Butt-Weld End Preparations
- NACE MR0175: Sulfide Stress Cracking Resistant Metallic Materials for Oilfield Equipment
- NACE MR0103: Materials Resistant to Sulfide Stress Cracking in Corrosive Petroleum Refining Environments
- A694 F52 - 70: High Transmission Service
- MSS SP-79: Socket Weld Reducer Inserts
- MSS SP-97: Branch Outlets – Socket Weld, Threaded, & Butt-Weld
- PFI ES-16: Bosses & Plugs for Radiographic Inspection of Pipe Welds

## Typical Industries Served

- B31.1: Power Piping
- B31.3: Process Piping
- B31.4: Pipeline Transportation
- B31.8: Gas Transmission
- B31.9: Building Services Piping (HVAC)
- B31.11: Slurry Transportation Piping Systems
- ASME Sec. VIII, Div. 1: Boiler & Pressure Vessel



## About WOI

WOI is a certified Woman-owned domestic manufacturer. We produce high pressure piping components in over 40 grades of steel known in the ASME code as "Branch Connections" (Branchettes<sup>®</sup>). Some industries served are Refinery/Chemical, Power Plants, Pipeline, Shipbuilding, Beverages, Pulp & Paper, Food Processing, Pharmaceuticals & Commercial HVAC Systems.

We build all products with pride, and your satisfaction is our top priority! It would be our sincerest pleasure to service your branch connection needs. Please contact us with any questions you have regarding our company and products. We are on call 24 hours a day.

# Table of Contents

Technical Information .....	a
Table of Contents .....	1
Product Overview .....	2 & 3
Marking Details for WOI Branchettes® .....	4
Branchette® vs. Conventional Welding Tee .....	5
Butt-Weld Branchettes® .....	6
Butt-Weld HVAC Branchettes® .....	7
Heavy Wall Branchettes® .....	8
Seamless Flanged Branchettes® .....	9
Butt-Weld, Socket- Weld, & Threaded 45° Lateral Branchettes® & Elbow Branchettes® .....	10
Low Weld Volume Butt-Weld 45° Lateral Branchettes® & Elbow Branchettes® .....	11
Socket-Weld & Threaded Branchettes® .....	12
Low Weld Volume Branchettes® for Stainless Steel Applications .....	13
Couplets & Bosses .....	14
Nipple Branchettes® .....	15
HVAC Groovettes® .....	16 & 17
Insert Branchettes® .....	18
SRV Insert Branchettes® .....	19
Nozzles .....	20
Seamless Crosses, Tees, Laterals, Wyes, Caps, & Hemi-Heads .....	21
Studding Outlets .....	22 & 23
Radiographic & Gamma Plugs .....	24
Industry Terms .....	25
Pipe Sizes & Schedules .....	26
Wall Thickness .....	27
Bore Chart (I.D. of Pipe) .....	27
Tap & Drill Sizes .....	28
Fractions to Decimals .....	28
Measurement Conversions .....	28
Nominal Sizes .....	28
Material Specifications Chart .....	29
Certifications & Registrations .....	29
Codes & Standards .....	30

## Branchette® Family

Integrally Reinforced Branch Connections designed in accordance with MSS SP-97.

The WOI Branchette® is available in Butt-Weld, Socket-Weld and Threaded (NPT) configurations.

The Butt-Weld Branchette® is available up to nominal size 72 in. and the Socket-Weld and Threaded Branchettes® are available up to nominal size 4 in. The Branchette® can be manufactured to match any pipe size or wall thickness and can be manufactured for a 90°, 45°, tangential or hill-side elbow application.

## Flanged Branchettes®

The Flanged Branchette® is a seamless one piece construction that replaces a branch connection, a pipe nipple and a weld neck flange. This allows for a greater control of height, the elimination of internal turbulence caused by a three piece construction, and the elimination of two welds. The Flanged Branchette® is available in nominal sizes ½ in. through 2 in. and flange dimensions are in accordance with ASME or API specifications.

## RT Plugs

RT Plugs (i.e. Access Hole Plugs, Gamma Plugs, or X-Ray Plugs) are inserted and seal welded to close access holes used for the radiographic inspection of pipe butt welds where the radiographic source is located on the inside of the pipe. RT Plugs are manufactured in accordance with PFI ES-16.

## Thermowells

Thermowells are used to provide isolation between a temperature sensor (often a thermocouple) and the environment whose temperature is to be measured. WOI manufactures thermowells with a single well, double well, staggered I.D., angular offsets, or stepped I.D. All thermowells are manufactured in accordance with customer specifications.

## Insert Branchettes®

Integrally Reinforced Insert Branch Connection designed specifically for cyclic conditions, extreme pressures/temperatures, safety relief valve applications, or critical service. The round installation skirt allows for a fully interpretable X-Ray of the weld.

Also available (when the end user accepts no other fitting) is the traditional Sweep Insert Branchette®.

Note: The Butt-Weld Insert Branchette® is available at a fraction of cost and time compared to the Sweep Insert Branchette®.

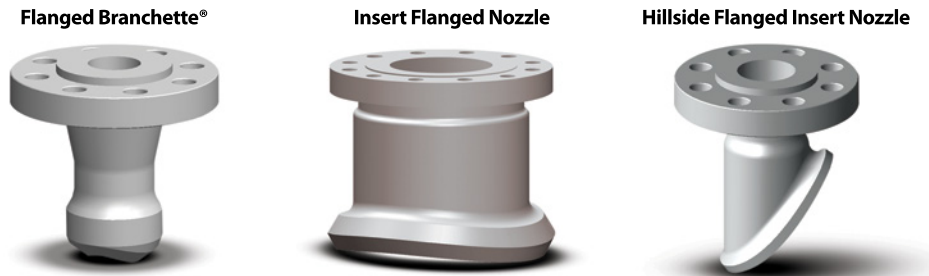
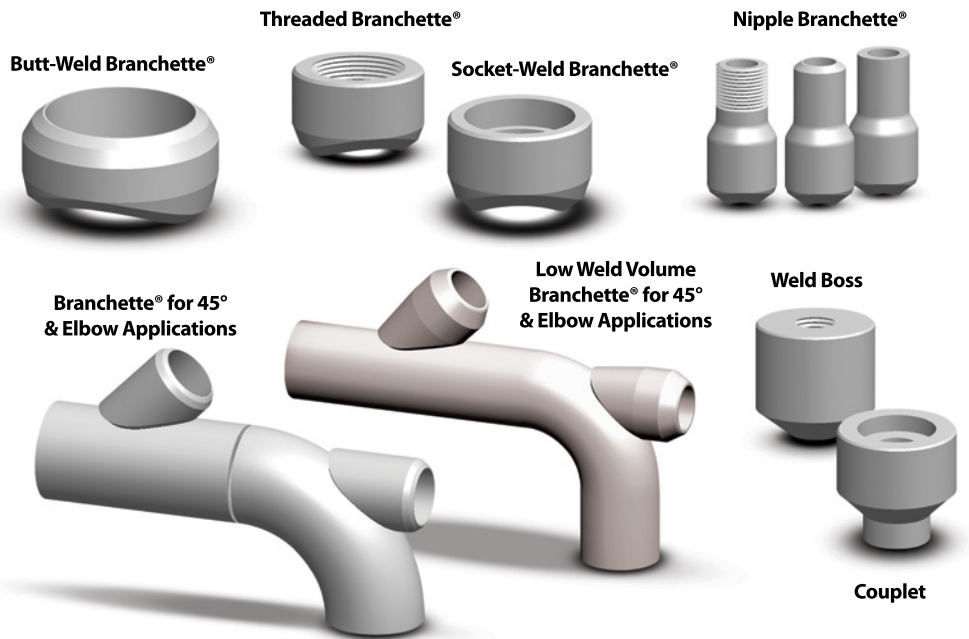

RT, X-Ray, & Gamma Plugs

Thermowells

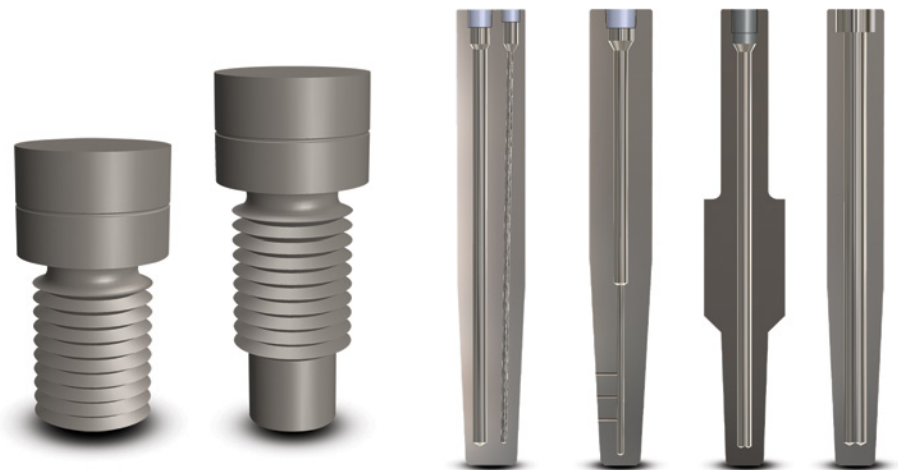

Butt-Weld Insert Branchette®

Sweep Insert Branchette®

Flanged Insert Branchette®

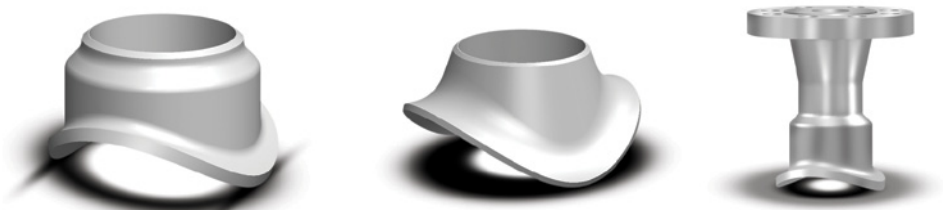

**Butt-Weld Tee**  
*Seamless Only*

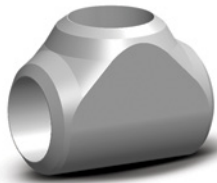

**Butt-Weld Lateral**  
*Seamless Only*



**Butt-Weld Cross**  
*Seamless Only*



**Butt-Weld Wye**  
*Seamless Only*

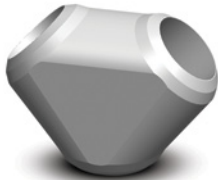

**Butt-Weld Cap**

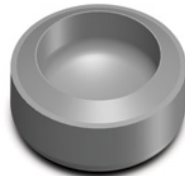

**Hemispherical Cap**

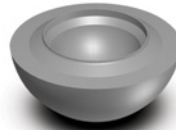

**Heavy Wall Butt-Weld Branchette®**



**Butt-Weld Nozzle Set-On Application**

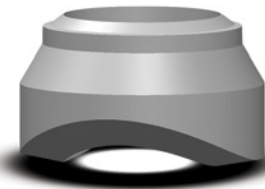

**Butt-Weld Nozzle Set-In Application**



**Raised Face Studding Outlet**

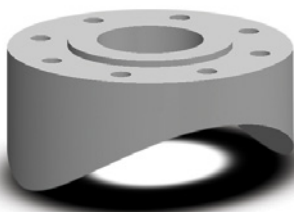

**Insert Studding Outlet**



**Butt-Weld HVAC Branchette®**  
*Low Weld Volume*

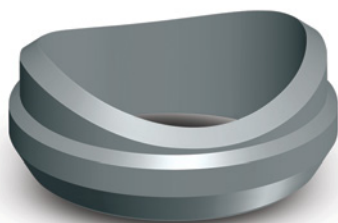

**Butt-Weld HVAC Groovette®**

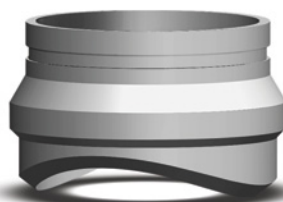

## Butt Weld Fittings

Seamless non-commodity Butt-Weld Fittings available up to nominal size 18 in.; can be manufactured to match any schedule or wall thickness. Caps are available in 2:1 elliptical and hemispherical design.

## Heavy Wall Branchettes®

Integrally Reinforced Branch Connections designed for piping exceeding X-STG. All WOI Branchettes® restore the header piping back to its original pressure retaining strength however, not all codes allow the usage of proof tested fittings. When requested, WOI can provide you with Reinforcement Calculations (Area Replacement Calculations) in accordance with ASME: B31.1, B31.3, B31.4, B31.8, Section I or Section VIII Div.1.

## Nozzles

All Nozzles are manufactured in accordance with customer specifications. Nozzles can be manufactured for "set-on", traditional "set-in" and "set-in" with insert weld skirt applications. When required, Reinforcement Calculations in accordance with your applicable piping or pressure vessel code can be provided.

## Studding Outlets

These pressure vessel branch connections can be manufactured to match any ASME or API flange facing requirements. The minimum thickness ("T" Dimension) and drilling / thread depth are in accordance with ASME Sect VIII Div I Paragraph UG-43(d) and (g). Studding Outlets can be manufactured for "set-on", "set-in" and tangential applications.

## HVAC Branchettes® & Groovettes®

Why use a branch connection designed for ASME B31.1 or B31.3 for B31.9 application? The HVAC Branchette® exceeds all the requirements of ASME B31.9 while maintaining a reduced installation diameter. This translates to reduced weld metal and reduced weld distortion caused to the light walled header piping. The HVAC Branchette® is available up to nominal size 72 in.

The Groovette® is a seamless one piece grooved branch connection that eliminates the need to buy a butt-weld branch connection and a pipe nipple. The groove can be machined to match any existing standard or customer specification. The WOI Groovette® is available in nominal sizes 3 in through 24 in.

# Marking Details for WOI Branchettes®



Phone: 281.590.0190 • Fax: 281.590.1415 • 24 Hour: 1.888.610.0777  
 ISO 9001:2008 & PED certified - Canadian registered in all provinces.

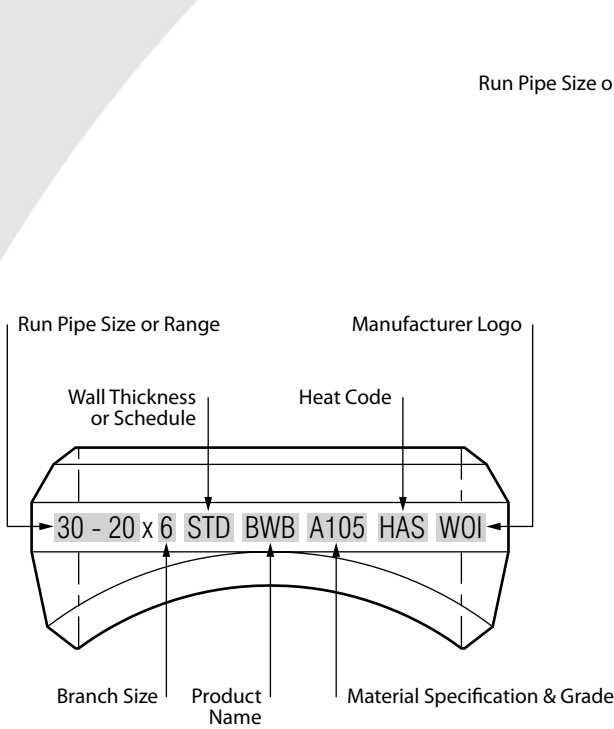

**Butt Weld Branchette® (BWB)**

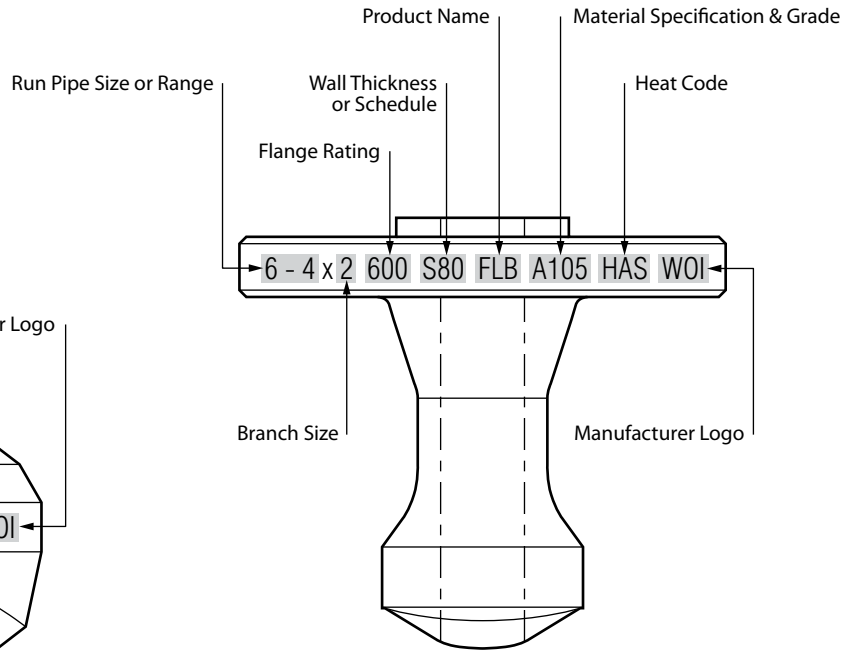

**Flanged Branchette® (FLB)**

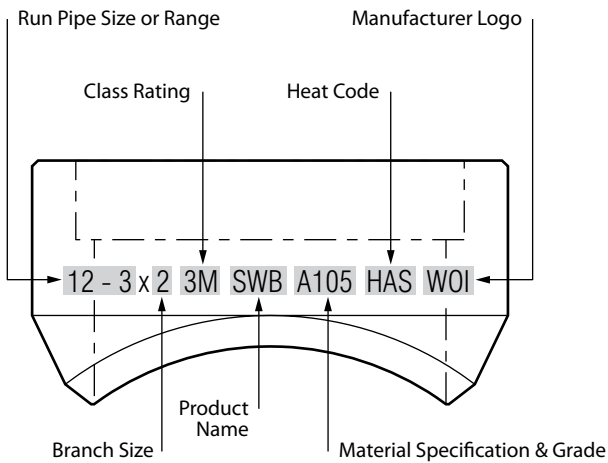

**Socket Weld Branchette® (SWB)**

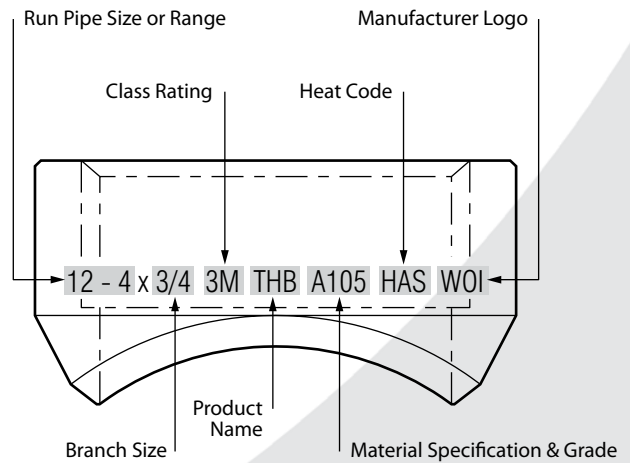

**Threaded Branchette® (THB)**

# Branchette® vs. Conventional Welding Tee



Phone: 281.590.0190 • Fax: 281.590.1415 • 24 Hour: 1.888.610.0777  
ISO 9001:2008 & PED certified - Canadian registered in all provinces.



## Where and Why to use an Integrally Reinforced Branchette® in lieu of a Conventional Welding Tee

Our "Integrally Reinforced Branchette®" (IRB) offers the following advantages:

1. Our "IRB" could cost more than 50% less than the conventional weld tee.
2. Fabrication time to install our "IRB" could be less than half the time required to install the weld tee.
3. Our "IRB" requires one weld where the weld tee requires two, which also eliminates an NDE/Inspection report.
4. Our "IRB" restores the run pipe to its original pressure retaining strength.
5. Our "IRB" consolidation features can greatly reduce stock inventory.
6. Our "IRB" allows the flexibility to quickly and easily place it at any location along the header - thus quick and easy alignment.
7. Our "IRB" is more readily available in a greater number of material grades and pipe schedules.
8. Our "IRB" is capable of meeting all Piping and Pressure Vessel codes.

Fabricators, stocking distributors, and end user alike enjoy the advantages of an Integrally Reinforced Branchette® employ over that of a conventional welding tee.

The diagrams below show an Integrally Reinforced Branchette® and a conventional welding tee. Both the conventional welding tee and an Integrally Reinforced Branchette® form a "T" intersection, joining the run and branch pipes together at a predetermined location.

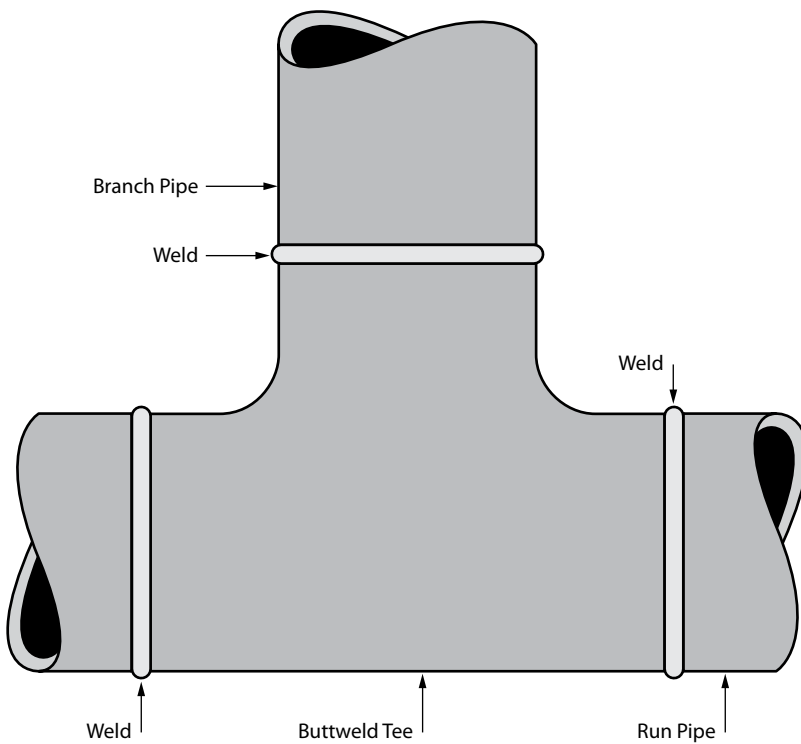

**Conventional Welding Tee**

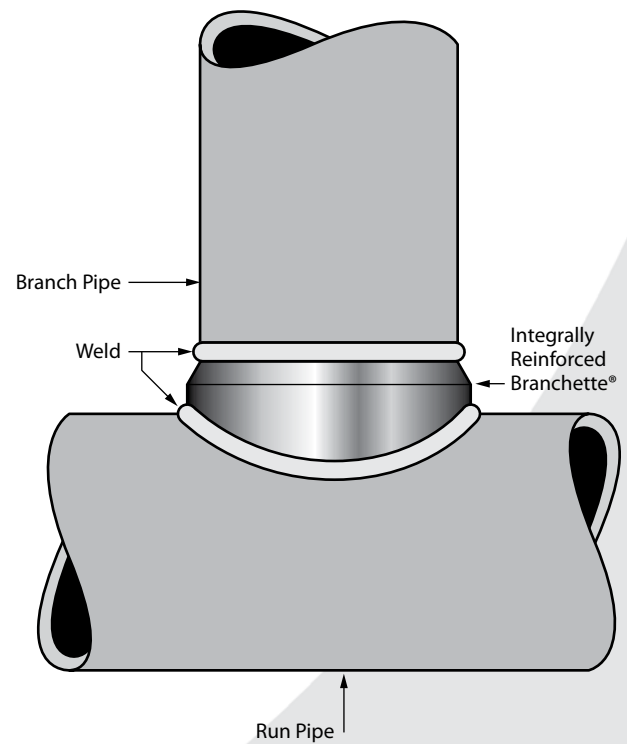

**Integrally Reinforced Branchette®**

WOI is a world class leader in the design, manufacturing and testing of Integrally Reinforced branch connections. Call us for your next branch connection requirements or a solution to your special problem.

Made in the USA.

# Butt-Weld Branchettes®

dimensions & weights

Complies with MSS-SP-97

www.woihouston.com



Phone: 281.590.0190 • Fax: 281.590.1415 • 24 Hour: 1.888.610.0777  
ISO 9001:2008 & PED certified - Canadian registered in all provinces.

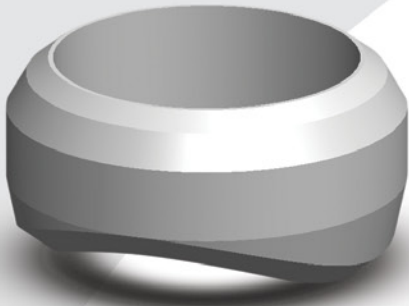

**Dimensions:** MSS SP-97  
**Sizes:** 1/8" thru 72"  
**Schedules:** STD thru XXS  
**Materials:** All material grades

## Minimum Weld Profile Details

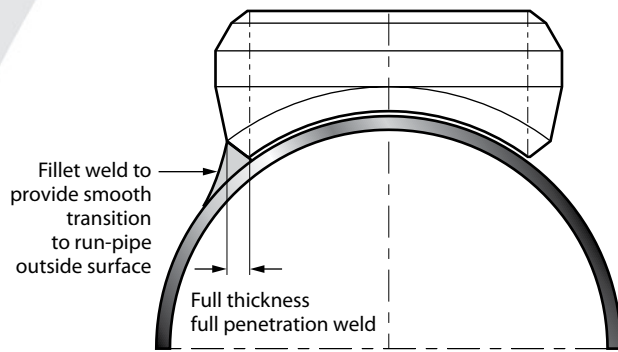

Transverse Section

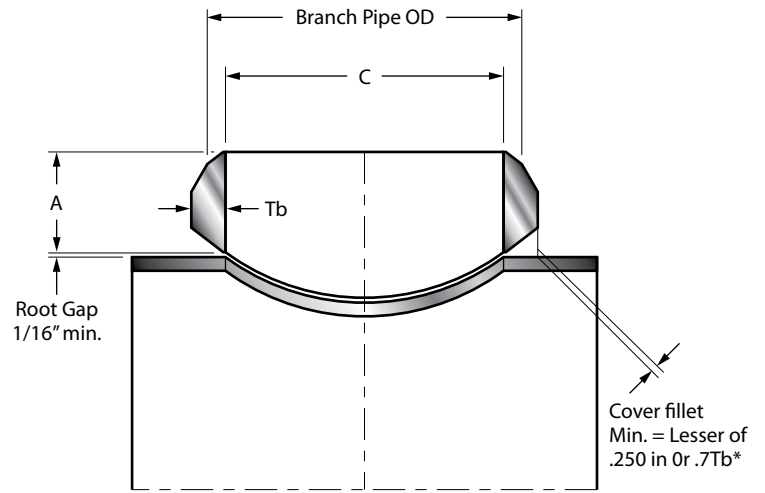

Longitudinal Section

\* = Ref: B31.3 Par 328.5.4 Fig: 328.5.4D1

NOMINAL SIZE	STANDARD			X - STRONG			SCHEDULE 160			XX - STRONG		
	A	C	WEIGHT	A	C	WEIGHT	A	C	WEIGHT	A	C	WEIGHT
1/8	5/8	0.269	0.08	5/8	0.215	0.10	.	.	.	.	.	.
1/4	5/8	0.364	0.08	5/8	0.302	0.10	.	.	.	.	.	.
3/8	3/4	0.493	0.09	3/4	0.423	0.15	.	.	.	.	.	.
1/2	3/4	0.622	0.12	3/4	0.546	0.12	1-1/8	0.464	0.24	1-1/8	0.252	0.23
3/4	7/8	0.824	0.28	7/8	0.742	0.21	1-1/4	0.612	0.39	1-1/4	0.434	0.65
1	1-1/16	1.049	0.34	1-1/16	0.957	0.43	1-1/2	0.815	0.62	1-1/2	0.599	0.78
1-1/4	1-1/4	1.380	0.70	1-1/4	1.278	0.72	1-3/4	1.160	1.16	1-3/4	0.896	1.16
1-1/2	1-5/16	1.610	0.90	1-5/16	1.500	0.88	2	1.338	1.80	2	1.100	1.60
2	1-1/2	2.067	1.10	1-1/2	1.939	1.25	2-3/16	1.687	2.30	2-3/16	1.503	2.50
2-1/2	1-5/8	2.469	2.30	1-5/8	2.323	2.70	.	.	.	.	.	.
3	1-3/4	3.068	2.50	1-3/4	2.900	3.80	.	.	.	.	.	.
3-1/2	1-7/8	3.548	4.50	1-7/8	3.364	5.00	.	.	.	.	.	.
4	2	4.026	5.90	2	3.826	6.20	.	.	.	.	.	.
5	2-1/4	5.047	6.40	2-1/4	4.813	9.60	.	.	.	.	.	.
6	2-3/8	6.065	10.50	3-1/16	5.761	15.10	.	.	.	.	.	.
8	2-3/4	7.981	18.00	3-7/8	7.625	28.70	.	.	.	.	.	.
10	3-1/16	10.020	27.20	3-11/16	9.750	36.20	.	.	.	.	.	.
12	3-3/8	12.000	44.00	4-1/16	11.750	67.00	.	.	.	.	.	.



# Butt-Weld HVAC Branchettes®

## dimensions

Complies with ASME B31.9

www.woihouston.com

Phone: 281.590.0190 • Fax: 281.590.1415 • 24 Hour: 1.888.610.0777  
ISO 9001:2008 & PED certified - Canadian registered in all provinces.

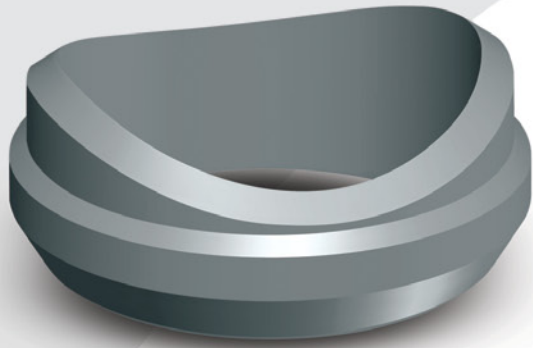

**Dimensions:** ASME B31.9  
**Sizes:** 4" thru 72"  
**Schedules:** STD  
**Materials:** A105, 304L, & 316L

### Mechanical Application

#### Minimum Weld Profile Details

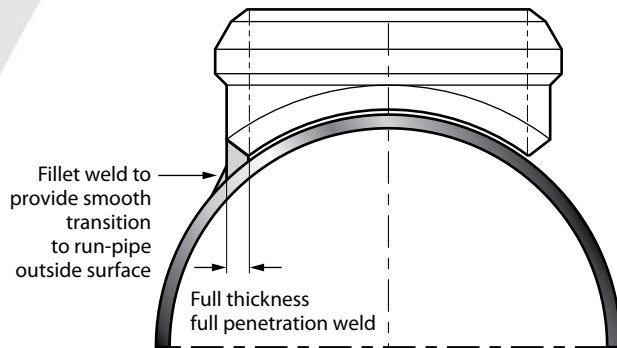

Transverse Section

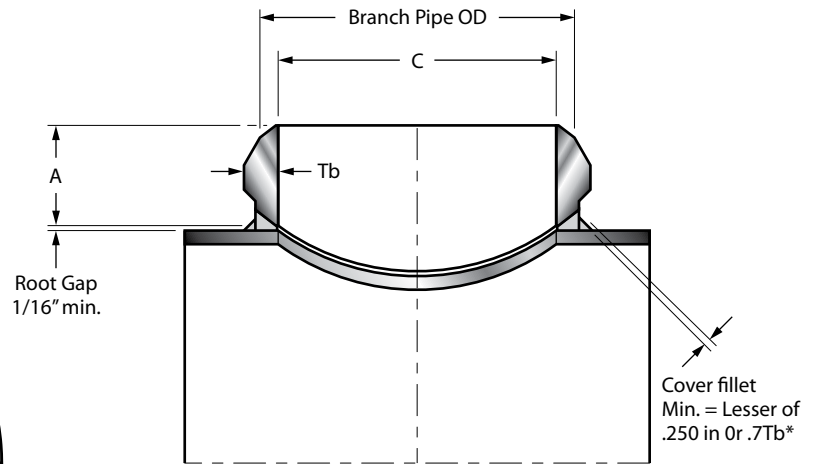

Longitudinal Section

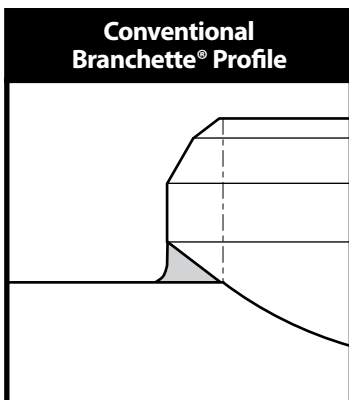
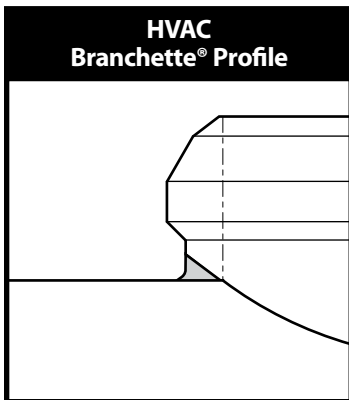

OUTLET SIZE	STANDARD	
	A	
4	2	
5	2-1/4	
6	2-3/8	
8	2-3/4	
10	3-1/16	
12	3-3/8	
14	3-1/2	
16	3-11/16	
18	3-13/16	
20	4	
24	4-9/16	

Weights are based on Carbon Steel.

Made in the USA.

# Heavy Wall Branchettes® dimensions

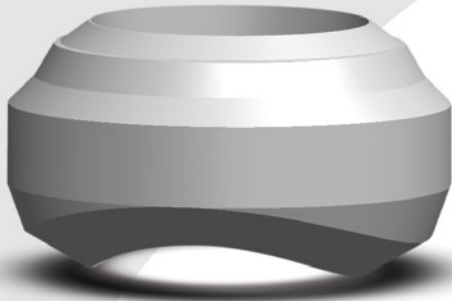

**Sizes:** 3" thru 72"  
**Schedules:** All wall thicknesses  
**Materials:** All material grades

## Minimum Weld Profile Details

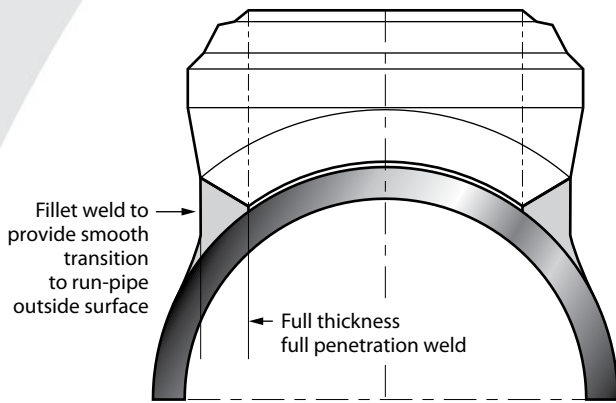

**Transverse Section**

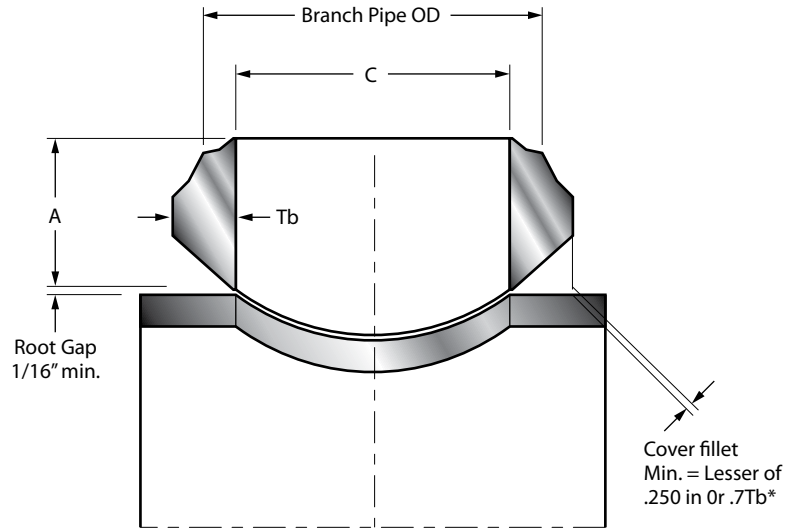

**Longitudinal Section**

\* = Ref: B31.3 Par 328.5.4 Fig: 328.5.4D1

NOMINAL SIZE	1	1-1/4	1-1/2	1-3/4	2	2-1/4	2-1/2	2-3/4	3
3	3-1/4	3-3/8	3-5/8	4-1/8	4-9/16	5	5-1/2	5-7/8	6-1/16
3-1/2	3-1/4	3-7/16	3-3/4	4-3/16	4-5/8	5-1/16	5-9/16	6	6-5/16
4	3-3/8	3-1/2	3-7/8	4-5/16	4-3/4	5-3/16	5-5/8	6-1/8	6-9/16
5	3-3/4	4	4-1/4	4-3/4	5-1/4	5-3/4	6-1/4	6-5/8	7-3/16
6	4-3/8	4-1/2	4-11/16	5-1/4	5-3/4	6-1/4	6-3/4	7-1/4	7-13/16
8	4-5/8	4-7/8	5-3/16	5-3/4	6-3/8	6-15/16	7-1/2	8-1/8	8-11/16
10	4-7/8	5	5-5/16	5-15/16	6-9/16	7-3/16	7-13/16	8-7/16	9-1/16
12	5-1/8	5-3/8	5-11/16	6-5/16	6-15/16	7-9/16	8-3/16	8-13/16	9-7/16

# Seamless Flanged Branchettes®



Complies with ASME B16.5

[www.woihouston.com](http://www.woihouston.com)

WELDING OUTLETS, INC.

Phone: 281.590.0190 • Fax: 281.590.1415 • 24 Hour: 1.888.610.0777  
ISO 9001:2008 & PED certified - Canadian registered in all provinces.

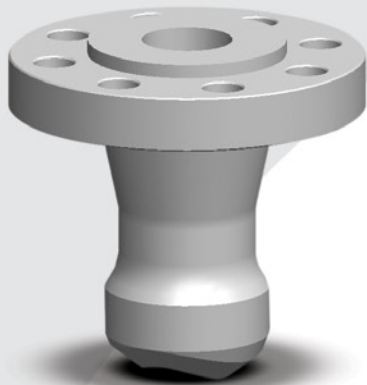

The Flanged Branchette® is available with any standard facing and with any specified bore. Special facings machined to your requirements can also be accommodated. The Flanged Branchette™ is ideal for multiple manifold outlets where consistent flange face height is required. Flange dimensions and tolerances are in accordance with ASME B16.5.

**Dimensions:** ASME B16.5

**Sizes:** 1/2" thru 4"

**Class:** 150 thru 2500

**Materials:** Carbon steel, low temperature steel, stainless steel & duplex or super duplex stainless steel.

## Eliminate

- 3-piece construction
- 3 material test reports
- 2 welds - 2 NDT inspections when required
- Costly fit up and fabrication time
- Weld protrusion in bore at weld points
- Inconsistent flange face height

## Advantages

- 1-piece construction
- 1 material test report
- 1 weld - 1 NDT inspection when required
- Reduced fit up and fabrication time
- Consistent flange face height
- Smooth seamless bore provides better flow

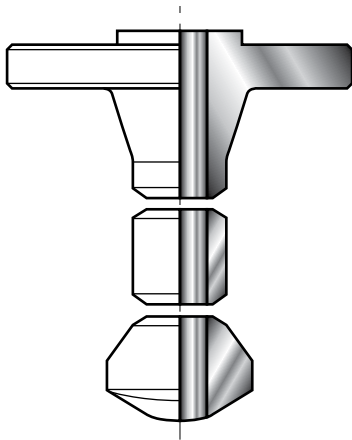

Branch Connection, Pipe Nipple, & Buttweld Flange

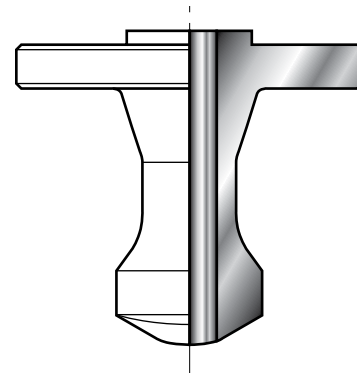

Flanged Branchette®

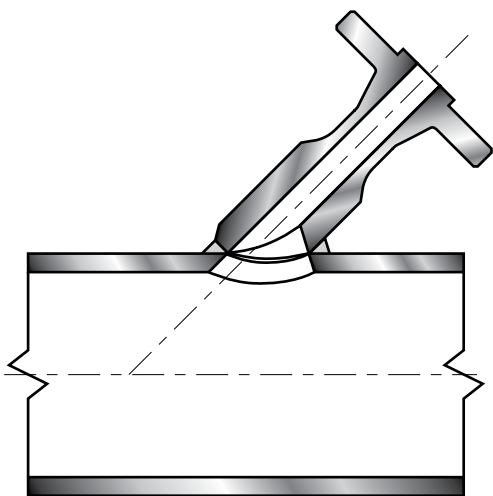

Flanged Lateral Branchette®

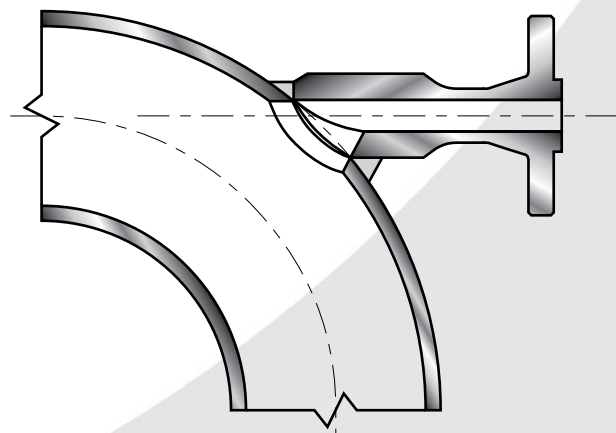

Flanged Elbow Branchette®

Made in the USA.

# Butt-Weld, Socket-Weld, & Threaded 45° Lateral Branchettes® & Elbow Branchettes® dimensions

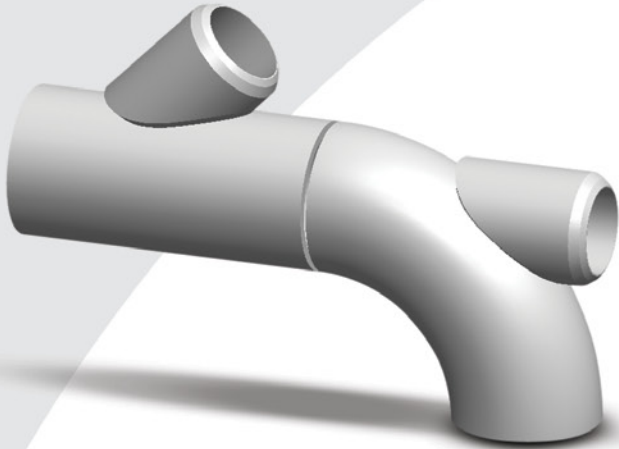

**Sizes:** 1/2" thru 48"  
**Schedules:** All schedules  
**Materials:** All material grades

1. Integrally Reinforced 45° Lateral and Elbow Branch Connections proof tested in accordance with Annex B of MSS SP-97.
2. Like the 90° Branchette®, these branch connections will restore the header pipe/ elbow back to its original pressure retaining strength.
3. Also Available is the 60° Lateral Branchette® and the Short Radius Elbow Branchette®.
4. "E" and "L" dimensions are available upon request.

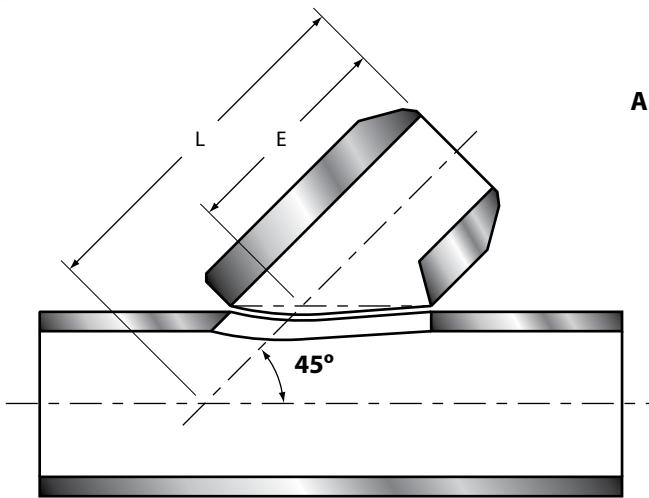

**Butt-Weld 45° Lateral Branchette® (BLB)**

ASME B16.9  
L.R. Elbow

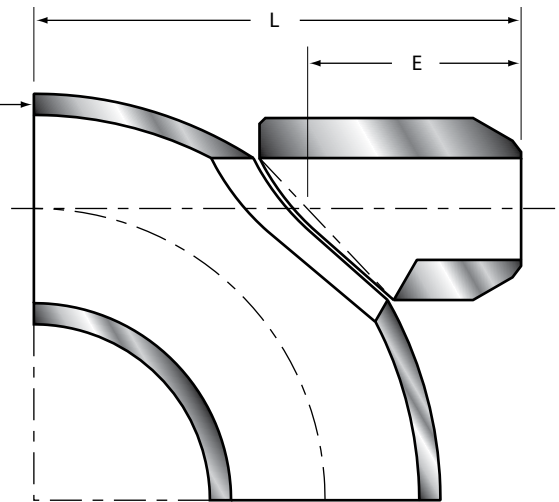

**Butt-Weld Elbow Branchette® (BEB)**

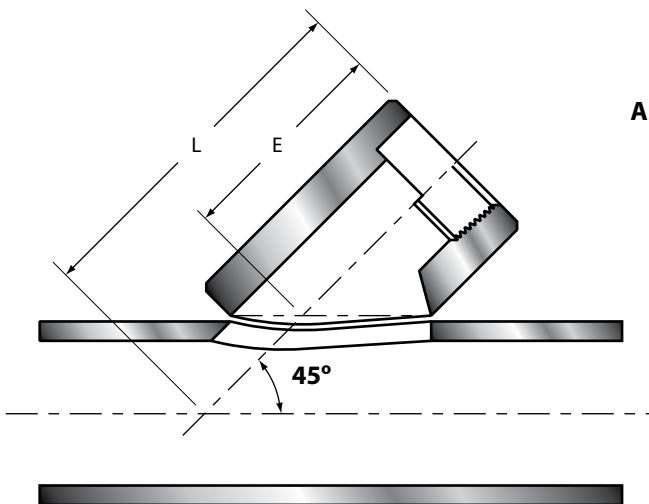

**Socket-Weld 45° Lateral Branchette® (SLB)  
Threaded 45° Lateral Branchette® (SLB)**

ASME B16.9  
L.R. Elbow

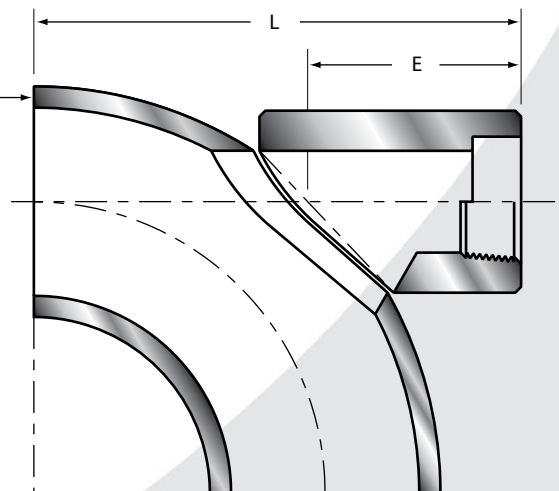

**Socket-Weld Elbow Branchette® (SEB)  
Threaded Elbow Branchette® (TEB)**

# Low Weld Volume Butt-Weld 45° Lateral Branchettes® & Elbow Branchettes® dimensions



**Schedules:** 5s, 10s, and 40s  
**Materials:** F304L and F316L

## For Stainless Steel Applications

1. Integrally Reinforced 45° Lateral and Elbow Branch Connections proof tested in accordance with Annex B of MSS SP-97.
2. Like the 90° Branchette®, these branch connections will restore the header pipe/ elbow back to its original pressure retaining strength.
3. Reduced installation diameter helps minimized distortion caused by welding to the header pipe.
4. "E" and "L" dimensions are available upon request.

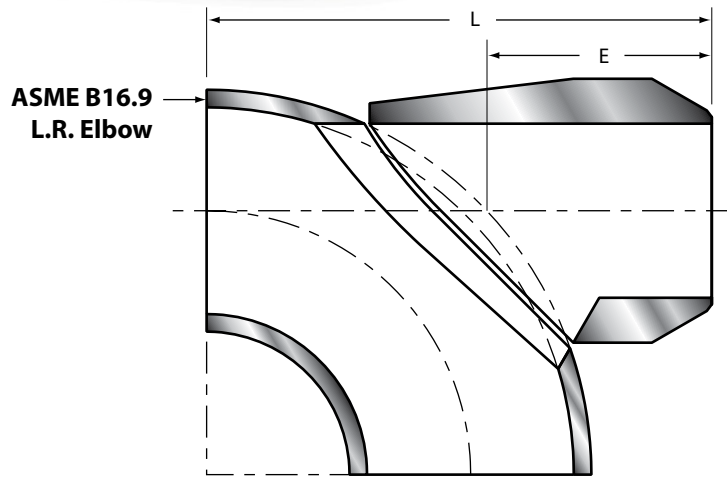

Low Weld Volume Butt-Weld  
Elbow Branchette® (LWV BEB)

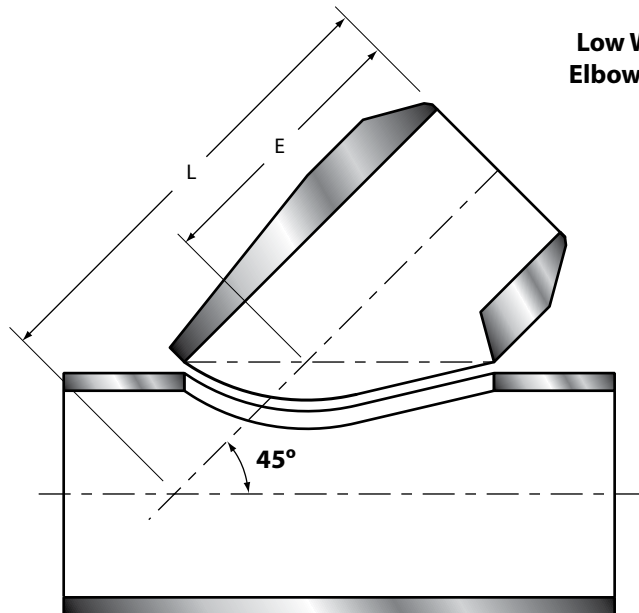

Low Weld Volume Butt-Weld  
45° Lateral Branchette® (LWV BLB)

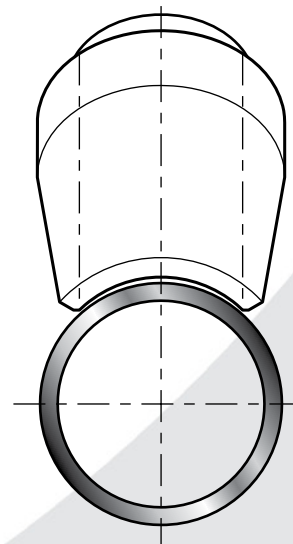

Low Weld Volume Butt-Weld  
45° Lateral Branchette® (LWV BLB)

# Socket-Weld & Threaded Branchettes®

dimensions & weights

Complies with MSS-SP-97 & ASME B16.11 [www.woihouston.com](http://www.woihouston.com)



Phone: 281.590.0190 • Fax: 281.590.1415 • 24 Hour: 1.888.610.0777  
ISO 9001:2008 & PED certified - Canadian registered in all provinces.

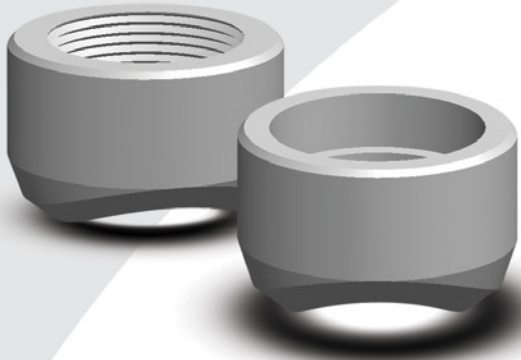

**Dimensions:** MSS SP-97 & ASME B16.11

**Sizes:** 1/8" thru 4"

**Class:** 3000, 6000, & 9000 Socket Weld  
3000, 6000, & 10000 Threaded

**Materials:** All material grades



## Minimum Weld Profile Details

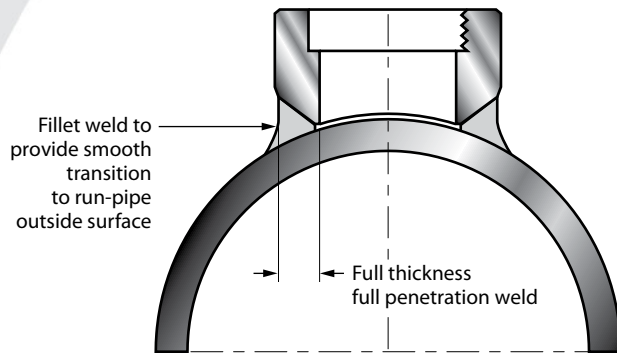

Transverse Section

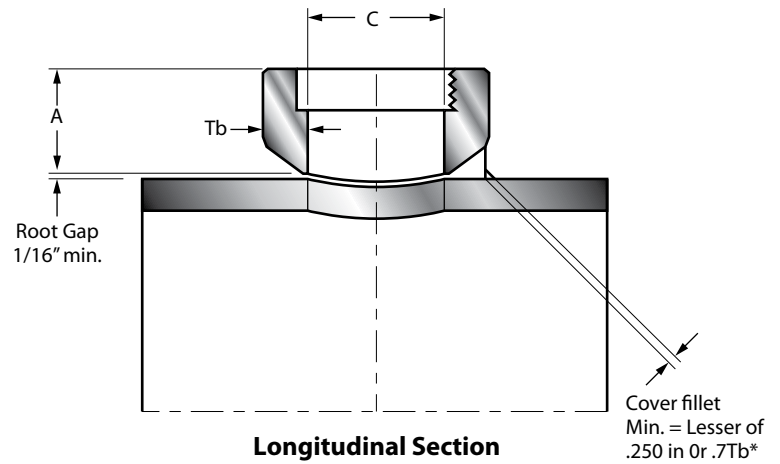

Longitudinal Section

\* = Ref: B31.3 Par 328.5.4 Fig: 328.5.4D1

NOMINAL SIZE	SWB-CLASS 3000			SWB-CLASS 6000			THB-CLASS 3000			THB-CLASS 6000		
	A	C	WEIGHT	A	C	WEIGHT	A	C	WEIGHT	A	C	WEIGHT
1/8	3/4	0.269	0.11	.	.	.	3/4	0.322	0.11	.	.	.
1/4	3/4	0.364	0.14	.	.	.	3/4	0.437	0.14	1-1/8	0.437	0.14
3/8	13/16	0.493	0.14	.	.	.	13/16	0.578	0.14	1-1/8	0.578	0.14
1/2	15/16	0.622	0.28	1-1/4	0.464	0.28	1	0.719	0.28	1-1/4	0.719	0.28
3/4	1-1/16	0.824	0.39	1-7/16	0.612	0.39	1-1/16	0.922	0.39	1-7/16	0.922	0.39
1	1-5/16	1.049	0.73	1-9/16	0.815	0.73	1-5/16	1.156	0.73	1-9/16	1.156	0.73
1-1/4	1-5/16	1.380	0.96	1-5/8	1.160	0.96	1-5/16	1.500	0.96	1-5/8	1.500	0.96
1-1/2	1-3/8	1.610	1.12	1-11/16	1.338	1.63	1-3/8	1.734	1.12	1-11/16	1.734	1.63
2	1-1/2	2.067	1.66	2	1.687	1.66	1-1/2	2.218	1.66	2-1/16	2.218	1.65

# Low Weld Volume Branchettes® (for Stainless Steel Applications)



Phone: 281.590.0190 • Fax: 281.590.1415 • 24 Hour: 1.888.610.0777  
ISO 9001:2008 & PED certified - Canadian registered in all provinces.

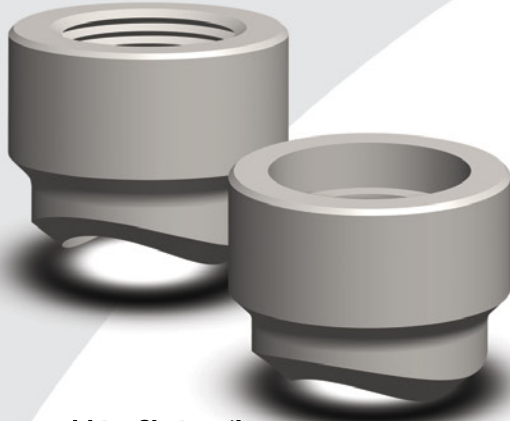

**Dimensions:** MSS SP-97 & ASME B16.11

**Sizes:** 1/8" thru 4"

**Class:** 3000 Socket Weld  
3000 Threaded

**Materials:** All 304/L & 316/L stocked - Other materials on request.

## Minimum Weld Profile Details

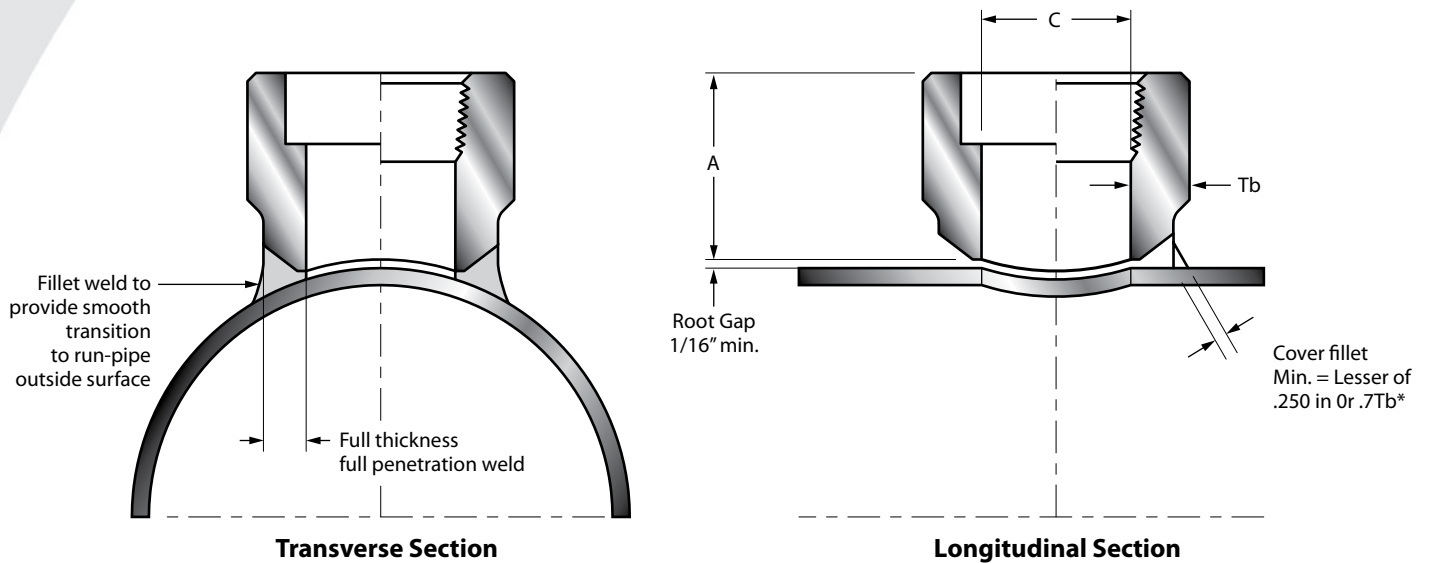

\* = Ref: B31.3 Par 328.5.4 Fig: 328.5.4D1

NOMINAL SIZE	SWB-CLASS 3000			THB-CLASS 3000		
	A	C	WEIGHT	A	C	WEIGHT
1/8	3/4	0.269	0.11	3/4	0.322	0.11
1/4	3/4	0.364	0.14	3/4	0.437	0.14
3/8	13/16	0.493	0.14	13/16	0.578	0.14
1/2	15/16	0.622	0.20	1	0.719	0.20
3/4	1-1/16	0.824	0.25	1-1/16	0.922	0.30
1	1-5/16	1.049	0.45	1-5/16	1.156	0.45
1-1/4	1-5/16	1.380	0.65	1-5/16	1.500	0.70
1-1/2	1-3/8	1.610	0.75	1-3/8	1.734	0.75
2	1-1/2	2.067	1.00	1-1/2	2.218	1.00

1. Proof Tested In Accordance with MSS SP 97.
2. Restores the header pipe back to its original pressure retaining strength.
3. Designed for Sch.5s, Sch.10s, Sch.40s and Sch.80s header piping.
4. Reduced installation diameter helps minimized distortion caused by welding to the header pipe.

# Couplets & Bosses dimensions

Complies with ASME B16.11

www.woihouston.com



Phone: 281.590.0190 • Fax: 281.590.1415 • 24 Hour: 1.888.610.0777  
ISO 9001:2008 & PED certified - Canadian registered in all provinces.

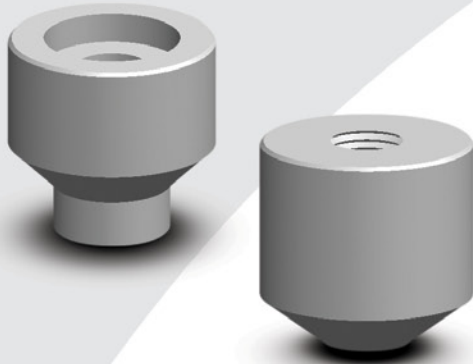

## For Small Diameter Connections to Pressure Vessels, Tanks and Piping Systems

Available in socket-weld, threaded, or combination socket-weld/threaded outlets. Combination and threaded types are available in 3000, 6000, and 10000 classes. Socket-weld bosses and couplets are available for schedule 40 and schedule 80 (Class 3000), schedule 160 (Class 6000), schedule XXS (Class 9000).

**Dimensions:** ASME B16.11

**Sizes:** 1/4" thru 2"

**Materials:** All material grades

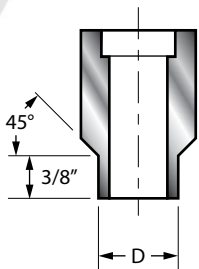

**Socket-Weld Couplet**

Part No. SWCB

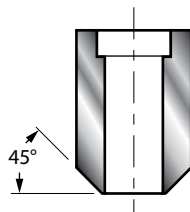

**Socket-Weld Boss**

Part No. SWWB

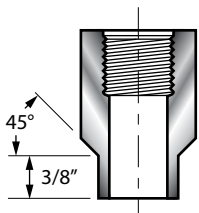

**Threaded Couplet**

Part No. THCB

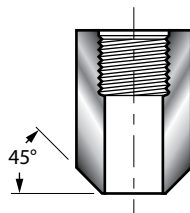

**Threaded Boss**

Part No. THWB

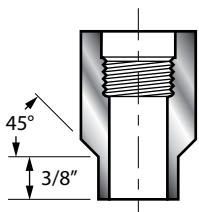

**Combination Couplet**

Part No. CB CB

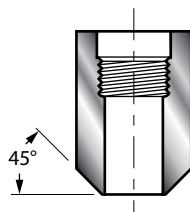

**Combination Boss**

Part No. CBWB

COUPLETS AND BOSSES						
NOMINAL SIZE	RATING	OAL SOCKET-WELD & THREADED COUPLET	OAL COMBINATION COUPLET	INSERT WELD RING	OAL SOCKET-WELD & THREADED BOSS	OAL COMBINATION BOSS
1/4	3000	1-3/16	1-9/16	11/16	1-3/8	1-3/4
	6000					
3/8	3000	1-3/16	1-9/16	13/16	1-3/8	1-3/4
	6000					
1/2	3000	1-5/16	1-11/16	15/16	1-1/2	1-7/8
	6000					
3/4	3000	1-3/8	1-7/8	1-1/16	2	2-1/2
	6000					
1	3000	1-11/16	2-3/16	1-5/16	2	2-1/2
	6000					
1 1/4	3000	1-7/8	2-3/8	1-11/16	2	2-1/2
	6000					
1 1/2	3000	2	2-1/2	1-15/16	2	2-1/2
	6000					
2	3000	2-1/4	2-7/8	2-7/16	2-1/2	3-1/8
	6000					



# Nipple Branchettes®

Phone: 281.590.0190 • Fax: 281.590.1415 • 24 Hour: 1.888.610.0777  
 ISO 9001:2008 & PED certified - Canadian registered in all provinces.

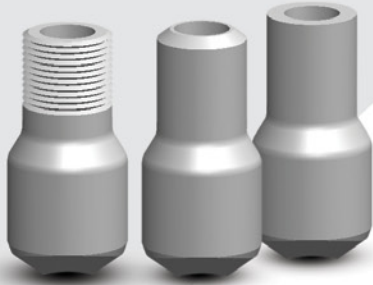

## A One Piece Integrally Reinforced Branch Fitting which Eliminates a Nipple & Branch Connection Weld.

Now available in 1/4" thru 4" Class XS, S/160, and XXS outlets. The Nipple Branchette® is available with Plain End, Threaded End, or Beveled End in all grades of materials. Standard heights are 3-1/2" 4-1/2" 5-1/2" and 6-1/2" and are available in all end conditions. Other heights are available upon request. Threaded ends have male NPT threads in accordance with ASME B1.20.1. Beveled ends are in accordance with ASME B16.25. Nipple Branchettes meet the requirements of ASME B31.3 for integrally reinforced branch connections.

### Eliminate

- 2-piece construction
- 2 material test reports
- 1 weld - 2 NDT inspections when required
- Costly fit up and fabrication time
- Weld protrusion in bore at weld points

### Advantages

- 1-piece construction
- 1 material test report
- 1 weld - 1 NDT inspection when required
- Reduced fit up and fabrication time
- Smooth seamless bore provides better flow

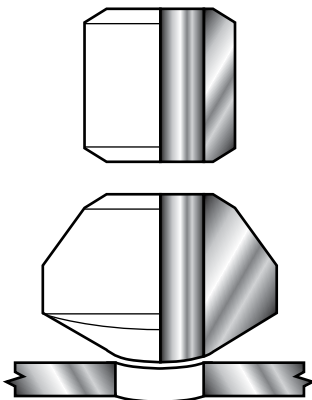

Branch Connection and Pipe Nipple

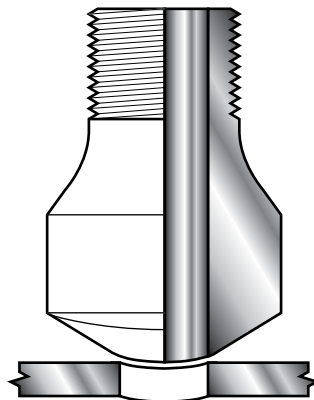

Threaded Nipple Branchette®

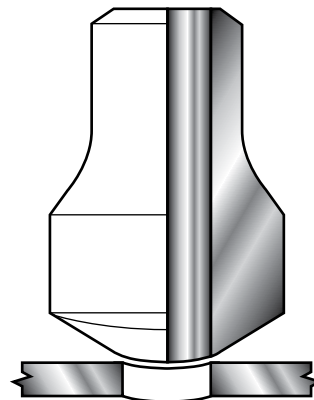

Buttweld or Beveled Nipple Branchette®

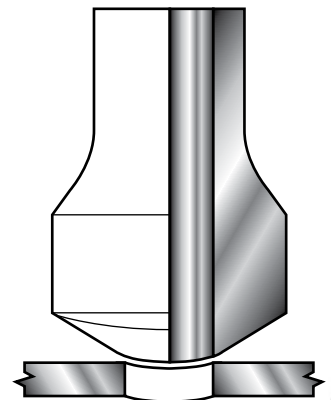

Plain End Nipple Branchette®

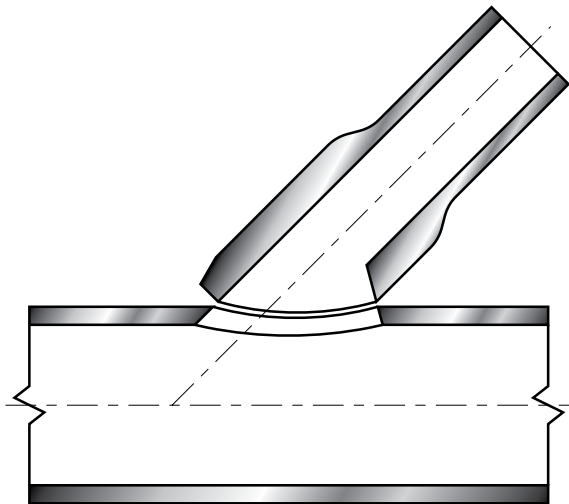

Nipple Lateral Branchette®

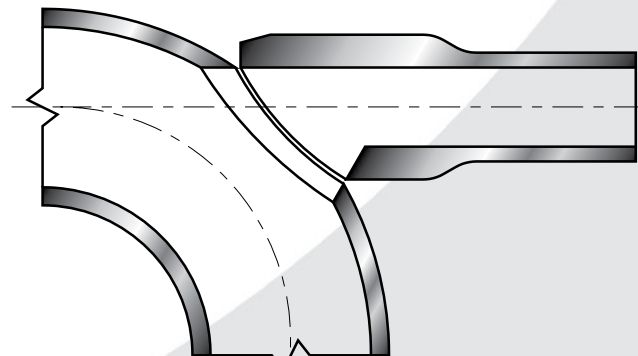

Nipple Elbow Branchette®

## Where and Why to use an Integrally Reinforced HVAC Groovette® in lieu of a Grooved Tee

Our "Integrally Reinforced HVAC Groovette®" will offer the following advantages:

1. Our "Groovette®" can offer substantial savings when compared to a grooved tee.
2. Our "Groovette®" eliminates the need for a costly grooved tee, two couplings and two gaskets.
3. Our "Groovette®" maintains a consistent standard height aids in design stage.
4. Our "Groovette®" has been PROOF TESTED IAW B31.9.
5. Our "Groovette®" offers pipe consolidations that will greatly reduce inventory.
6. Our "Groovette®" can be manufactured in any grade material.

Fabricators, stocking distributors, and end users alike can take advantage of the many benefits that the integrally reinforced HVAC Groovette® offers over that of a conventional grooved tee.

The diagrams below show the integrally reinforced HVAC Groovette® and a conventional grooved tee. Both the conventional grooved tee and the integrally reinforced Groovette® form a "T" intersection, joining the run and branch pipes together at a predetermined location. The integrally reinforced Groovette® can be supplied in reducing and full size configurations.

**Call WOI today @ 888.610.0777 and let us save you money while allowing you to meet your deadlines!**

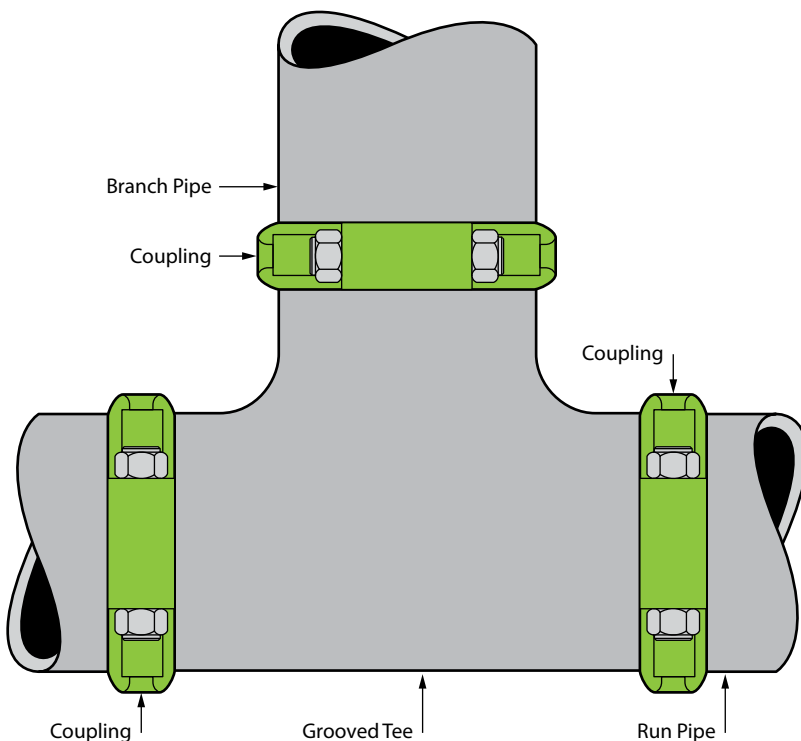

**Conventional Grooved Tee**

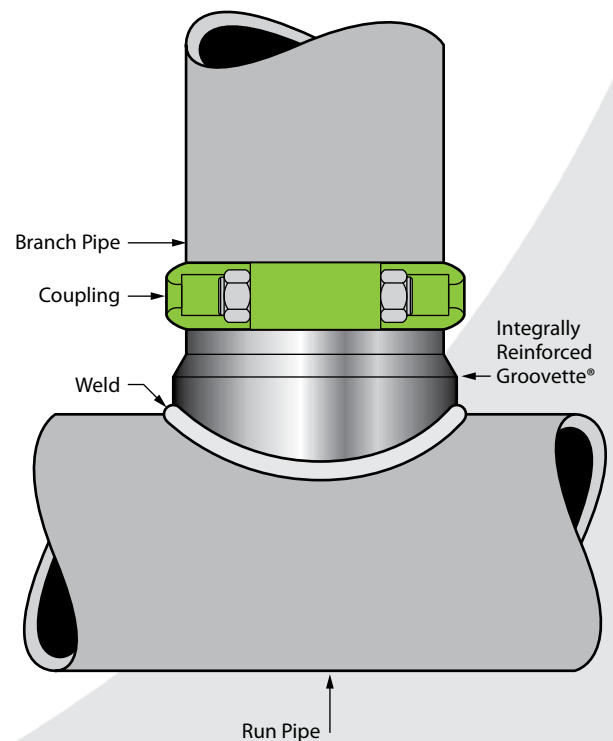

**Integrally Reinforced Groovette®**

Made in the USA.

# HVAC Groovettes® Low Weld Volume dimensions

Complies with ASME B31.9

www.woihouston.com

WELDING OUTLETS, INC.

Phone: 281.590.0190 • Fax: 281.590.1415 • 24 Hour: 1.888.610.0777  
ISO 9001:2008 & PED certified - Canadian registered in all provinces.

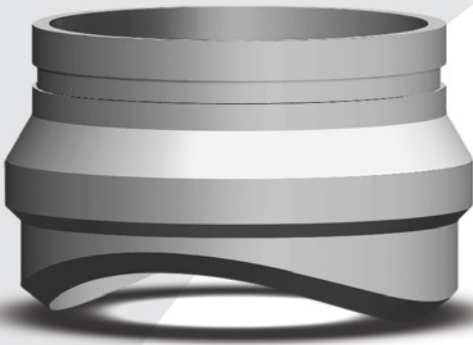

## The one piece, Grooved-End Integrally Reinforced Branch Outlet Fitting

Available in 2" thru 24" grooved-end outlets designed specifically for use with grooved-end mechanical piping systems. The WOI Groovette® utilizes a straight bore design with an industry standard machined groove. The WOI Groovette® eliminates the need for welding a grooved nipple to a standard outlet fitting. The WOI Groovette® is supplied to mate with standard bore pipe, unless otherwise specified. The WOI Groovette® is produced in A105, A182 F304/L, A182 F316/L materials, and can be manufactured from other materials upon request.

### Minimum Weld Profile Details

**Dimensions:** ASME B31.9

**Sizes:** 2" thru 24"

**Materials:** A105

NOMINAL SIZE	OD	D	ID	A	B	C
4	4.500	4.334	4.026	3.375	0.625	0.375
5	5.563	5.395	5.047	3.625	0.625	0.375
6	6.625	6.455	6.065	3.750	0.625	0.375
8	8.625	8.441	7.981	4.375	0.750	0.438
10	10.750	10.562	10.020	4.750	0.750	0.500
12	12.750	12.531	12.000	5.125	0.750	0.500
14	14.000	13.781	13.250	5.500	0.938	0.500
16	16.000	15.781	15.250	5.688	0.938	0.500
18	18.000	17.781	17.250	5.875	1.000	0.500
20	20.000	19.781	19.250	6.063	1.000	0.500
22	22.000	21.656	21.250	6.500	1.000	0.563
24	24.000	23.656	23.250	6.750	1.000	0.563

Other sizes and schedules are available on request. Standard "A" dimension as shown. Others available on request. Groove dimensions are in accordance with industry standard cut groove details.

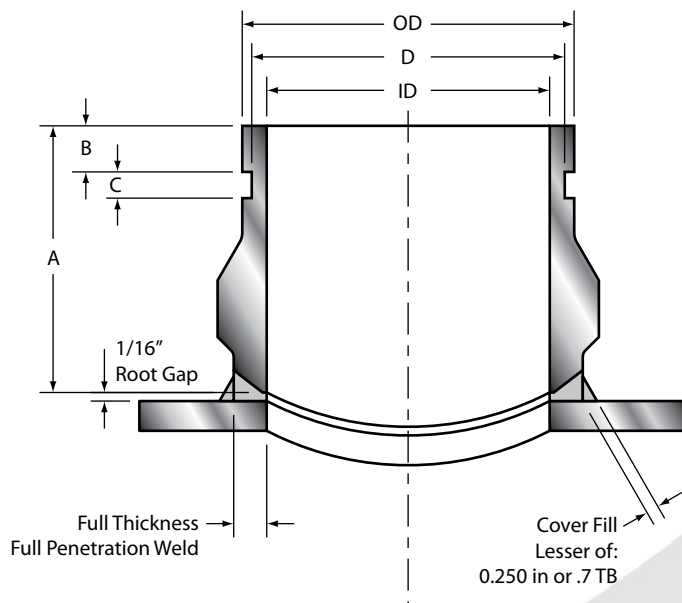

# Insert Branchettes® dimensions



Insert Branchettes® are designed specifically for critical service where a fully interpretable x-ray is required at the outlet-to-header weld. This integral design satisfies ASME code requirements by restoring 100% of pipe strength. The Insert Branchette Connection is ideal for cyclic conditions as in pressure cycles or thermal cycles. The Insert Branchette® Connection is designed and contoured to provide a flush fit with the run pipe O.D. and I.D. In most applications, the Insert Branch Connection is round, facilitating the use of automatic circle burning and welding equipment.

**Sizes:** 1/2" thru 72"  
**Materials:** All material grades

## Minimum Weld Profile Details

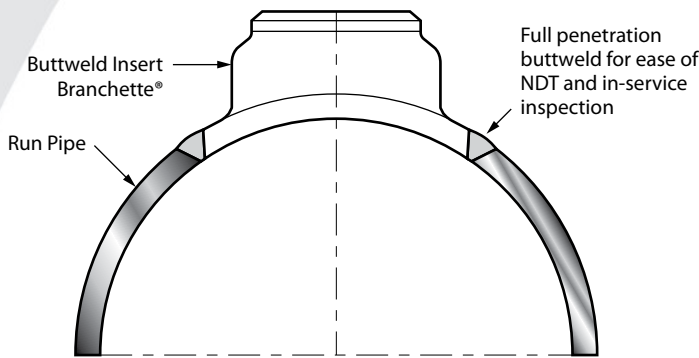

Transverse Section

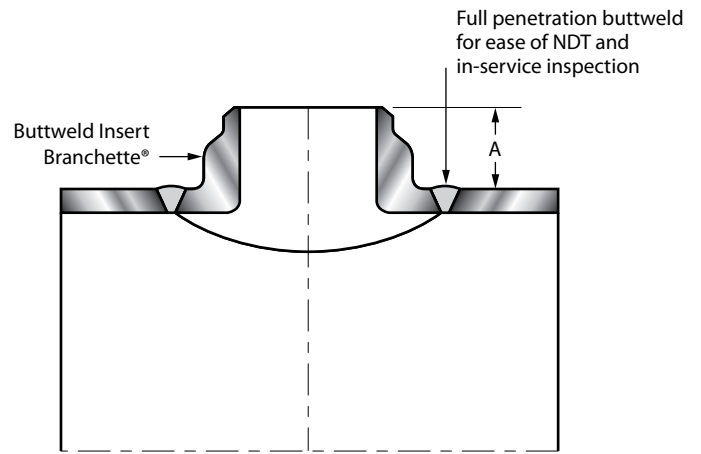

Longitudinal Section

\* = Ref: B31.3 Par 328.5.4 Fig: 328.5.4D1

## When Ordering An Insert Branchette Please Provide the Following Information:

- Quantity
- Material specification and grade
- Header size and schedule or thickness
- Outlet size and schedule or thickness
- Design code and edition
- Design pressure
- Design temperature
- Corrosion allowance

Insert Branchette® Connections are also available with Socket Weld, Threaded, and Flanged outlet ends.

NOMINAL SIZE	DIMENSIONS	
	A	
1/2	1-1/4	
3/4	1-1/4	
1	1-1/4	
1-1/4	1-1/4	
1-1/2	1-1/2	
2	1-1/2	
3	1-11/16	
4	2-1/16	
6	2-11/16	

\*"A" dimensions shown are nominal for STD & XS outlets. "A" dimensions for other schedules will vary.

Sweep Branchettes® are also available.

**Sizes:** 1/2" thru 24"  
**Schedules:** All schedules  
**Materials:** All material grades

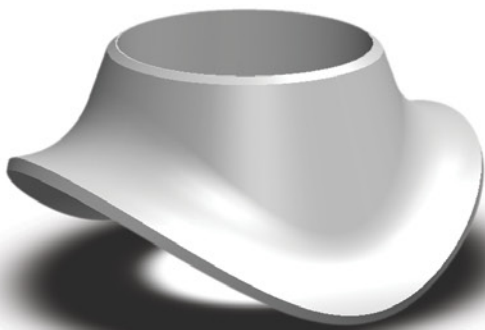

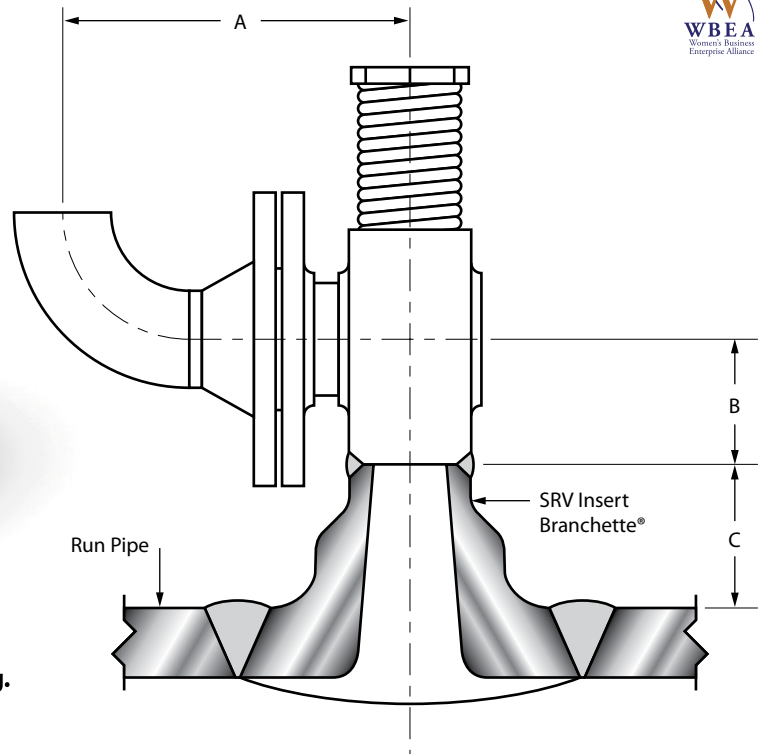
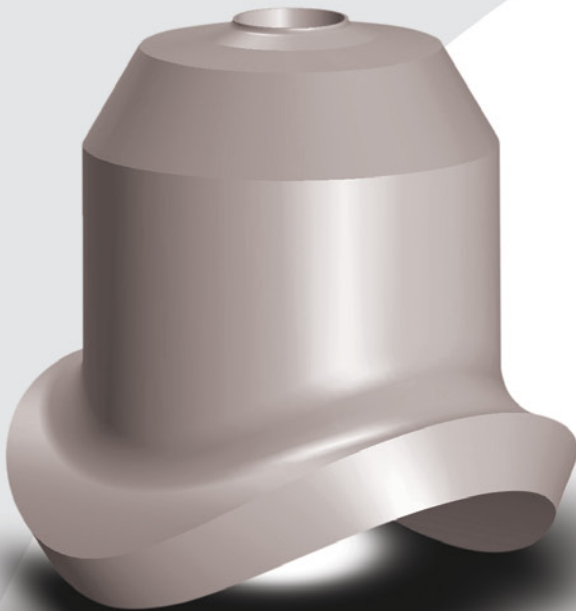

The WOI SRVIB is designed to meet piping design codes for pressure, temperature, vibration and/or external loading.

The Default Values are used to complete the design analysis when none are specified.

SRVIB DATA SHEET			
Provide the Information Below and Leave the Rest Up to Welding Outlets, Inc.			
<b>VALVE IDENTIFICATION</b>			
	Valve Number		Valve Name
<b>PROCESS NOMENCLATURE</b>			
	Header OD		Steam Pressure (PSIA)
	Header Wall		Steam Temperature (Deg. F°)
			Steam Flow (lbs/hr)
	Header Material		SRVIB Material
<b>VALVE NOMENCLATURE</b>			
	Weight of SRV (lbs)		Valve Inlet O.D.
	Relief Valve Set Pressure (PSIA)		Valve Inlet I.D.
	Flow Capacity of Valve (lbs/hr)		Valve Outlet I.D.
			Weld Prep (if required)
<b>DEFAULT DIMENSIONAL VALUES</b>			
	"A" Offset of Discharge Elbow (24" default if not given)	<b>DEFAULTS</b>	
	"B" Height of Relief Valve Seat (See chart at right for defaults)	<b>Outlet Nom. Size</b>	<b>Height Used</b>
	"C" Insert Branchette® A Dimension (maximum, minimum, optimize)	3"	6"
	"D" Valve Discharge Elbow O.D.	4"	8"
	"D" Valve Discharge Elbow Wall (Default is Schedule 40)	6"	8"
	"E" Valve Life Time (from SRV Valve MFG. 0.04 Sec. Default)	8"	10"



**Butt-Weld Nozzles  
for Set-on Application**

Butt-Weld Nozzle are most commonly produced in charted wall thickness / schedules. They are available in any combination of O.D. and wall thickness imaginable. We will manufacture to your specified dimensions.

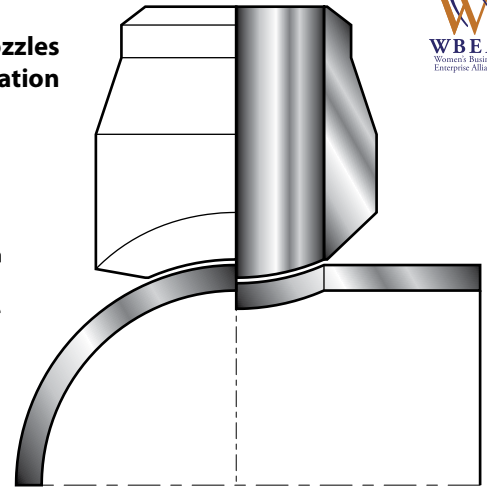

**Transverse Section    Longitudinal Section**

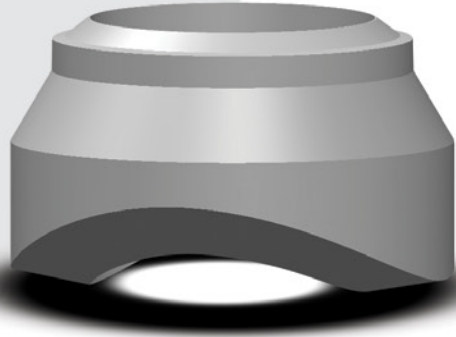

**Nozzles  
for Set-in Application**

Nozzles can be manufactured as flat or contoured for either a set-on or set-in application. The contour will match the radius of either the outer diameter or inner diameter of the header vessel.

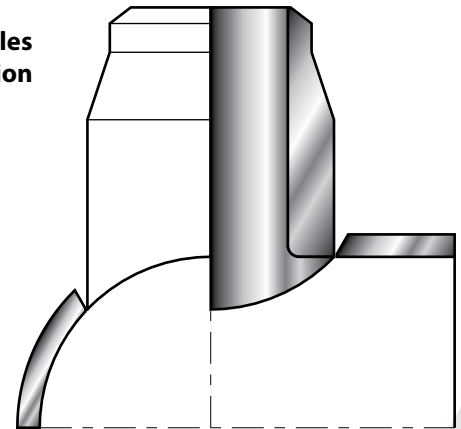

**Transverse Section    Longitudinal Section**



**Flanged Insert Nozzles**

Nozzle can be manufactured with a flanged facing to match ASME or API requirements. Insert nozzles can also be provided with an insert or "Q" style lips.

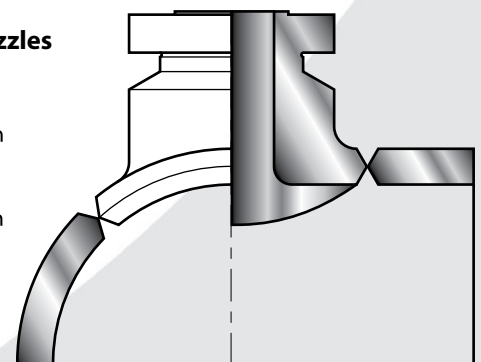

**Transverse Section    Longitudinal Section**

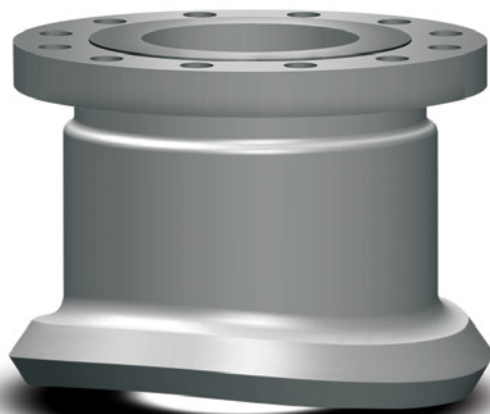

# Seamless Crosses, Tees, Laterals, Wyes, Caps, & Hemispheres

## dimensions

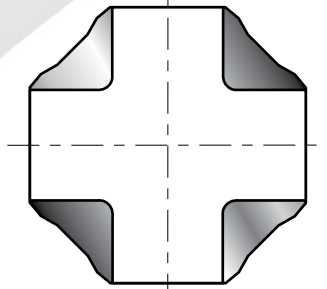
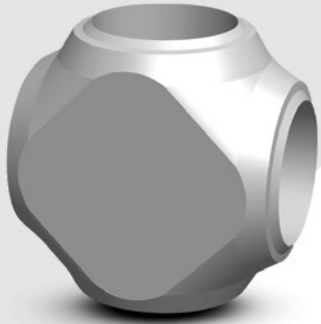

### Seamless Butt-Weld Crosses

**Dimensions:** ASME B16.9  
**Styles:** Straight, Reducing, and Cushing  
**Sizes:** 3/4" thru 20"  
**Materials:** All material grades

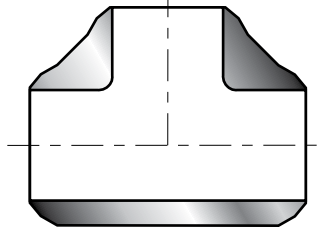
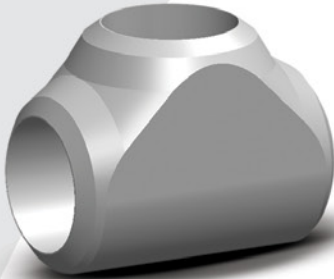

### Seamless Butt-Weld Tees

**Dimensions:** ASME B16.9  
**Styles:** Straight, Reducing, and Cushing  
**Sizes:** 3/4" thru 20"  
**Materials:** All material grades

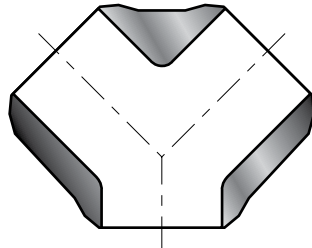
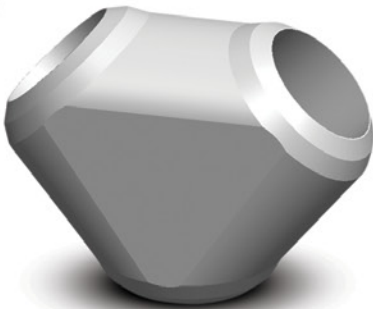

### Seamless Butt-Weld Wyes

**Styles:** Straight, Reducing, and Eccentric  
**Sizes:** 3/4" thru 20"  
**Materials:** All material grades

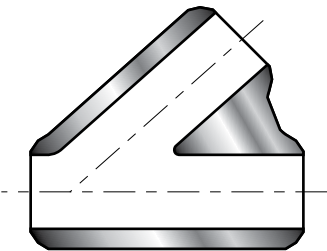
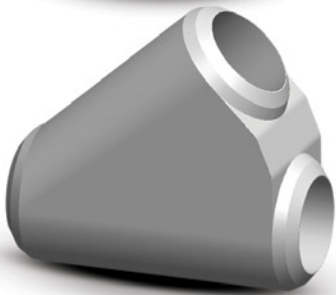

### Seamless Butt-Weld Laterals

**Styles:** Straight, Reducing, and Eccentric  
**Sizes:** 3/4" thru 18"  
**Materials:** All material grades

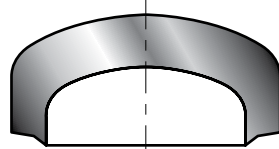
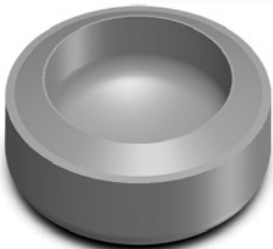

### Butt-Weld Caps

For applications calling for heavy wall or non-charted sizes.  
**Dimensions:** ASME B16.9  
**Sizes:** 3/4" thru 12"  
**Materials:** All material grades

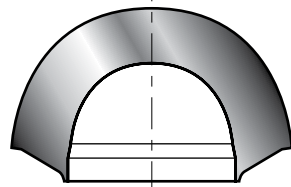
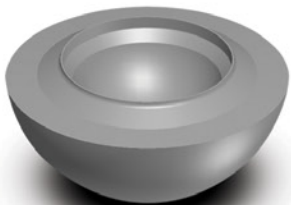

### Hemisphere Head Cap

For applications calling for heavy wall or non-charted sizes.  
**Dimensions:** ASME Section VIII Division 1  
**Sizes:** 3/4" thru 12"  
**Materials:** All material grades

# Studding Outlets dimensions



**Dimensions:** ASME Section VIII Division 1  
**Sizes:** 1/2" thru 24"  
**Materials:** All material grades

Studding outlets are available in sizes from 1/2" thru 24" and pressure classes from 150# thru 2500#. Studding outlets can be provided as flat as well as contoured bottoms to fit the O.D. or I.D. of shells, heads or cones. Offsets from vessel/head centerlines can also be accommodated. WOI can provide special machining for sight glass assemblies in accordance with your specified dimensions. We can also provide air test holes upon request.

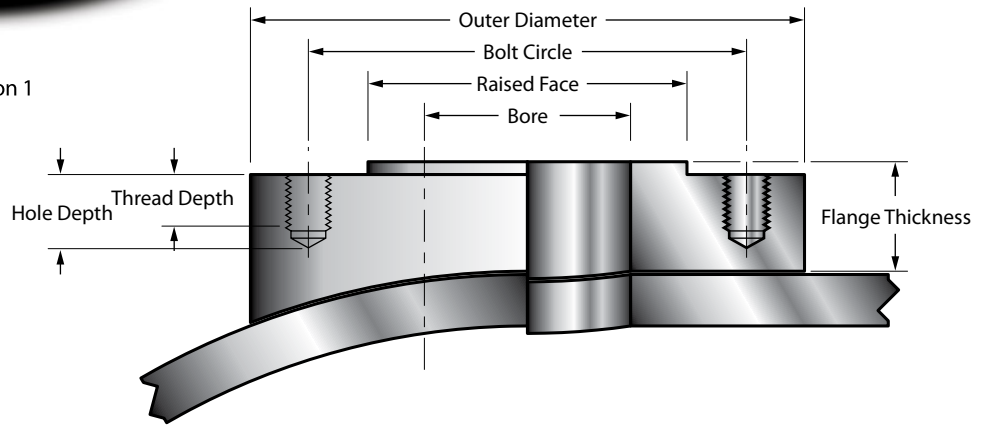

CLASS 150										
SIZE BORE	FLANGE THCK	OUTER DIAMETER	RAISED FACE	BOLT CIRCLE	NO. OF HOLES	HOLE SIZE	HOLE DEPTH	STUD BOLT		
								THRD SIZE	T.P.I.	THRD DEPTH
1/2	1.250	3.500	1.375	2.375	4	27/64	0.875	1/2	13	0.563
3/4	1.250	3.875	1.688	2.750	4	27/64	0.875	1/2	13	0.563
1	1.250	4.250	2.000	3.125	4	27/64	0.875	1/2	13	0.563
1 1/4	1.250	4.625	2.500	3.500	4	27/64	0.875	1/2	13	0.563
1 1/2	1.250	5.000	2.875	3.875	4	27/64	0.875	1/2	13	0.563
2	1.500	6.000	3.625	4.750	4	17/32	1.125	5/8	11	0.750
2 1/2	1.500	7.000	4.125	5.500	4	17/32	1.125	5/8	11	0.750
3	1.500	7.500	5.000	6.000	4	17/32	1.125	5/8	11	0.750
3 1/2	1.500	8.500	5.500	7.000	8	17/32	1.125	5/8	11	0.750
4	1.500	9.000	6.188	7.500	8	17/32	1.125	5/8	11	0.750
5	1.750	10.000	7.313	8.500	8	21/32	1.313	3/4	10	0.875
6	1.750	11.000	8.500	9.500	8	21/32	1.313	3/4	10	0.875
8	1.750	13.500	10.625	11.750	8	21/32	1.313	3/4	10	0.875
10	1.813	16.000	12.750	14.250	12	49/64	1.438	7/8	9	1.000
12	1.813	19.000	15.000	17.000	12	49/64	1.438	7/8	9	1.000

CLASS 300										
SIZE BORE	FLANGE THCK	OUTER DIAMETER	RAISED FACE	BOLT CIRCLE	NO. OF HOLES	HOLE SIZE	HOLE DEPTH	STUD BOLT		
								THRD SIZE	T.P.I.	THRD DEPTH
1/2	1.250	3.750	1.375	2.625	4	27/64	0.875	1/2	13	0.563
3/4	1.500	4.625	1.688	3.250	4	17/32	1.125	5/8	11	0.750
1	1.500	4.875	2.000	3.500	4	17/32	1.125	5/8	11	0.750
1 1/4	1.500	5.250	2.500	3.875	4	17/32	1.125	5/8	11	0.750
1 1/2	1.750	6.125	2.875	4.500	4	21/32	1.313	3/4	10	0.875
2	1.500	6.500	3.625	5.000	8	17/32	1.125	5/8	11	0.750
2 1/2	1.750	7.500	4.125	5.875	8	21/32	1.313	3/4	10	0.875
3	1.750	8.250	5.000	6.625	8	21/32	1.313	3/4	10	0.875
3 1/2	1.750	9.000	5.500	7.250	8	21/32	1.313	3/4	10	0.875
4	1.750	10.000	6.188	7.875	8	21/32	1.313	3/4	10	0.875
5	1.750	11.000	7.313	9.250	8	21/32	1.313	3/4	10	0.875
6	1.750	12.500	8.500	10.625	12	21/32	1.313	3/4	10	0.875
8	1.875	15.000	10.625	13.000	12	49/64	1.438	7/8	9	1.000
10	2.125	17.500	12.750	15.250	16	7/8	1.563	1	8	1.125
12	2.250	20.500	15.000	17.750	16	1	1.813	1 1/8	8	1.250



CLASS 600										
SIZE BORE	FLANGE THCK	OUTER DIAMETER	RAISED FACE	BOLT CIRCLE	NO. OF HOLES	HOLE SIZE	HOLE DEPTH	STUD BOLT		
								THRD SIZE	T.P.I.	THRD DEPTH
1/2	1.500	3.750	1.375	2.625	4	27/64	0.875	1/2	13	0.563
3/4	1.750	4.625	1.688	3.250	4	17/32	1.125	5/8	11	0.750
1	1.750	4.875	2.000	3.500	4	17/32	1.125	5/8	11	0.750
1 1/4	1.750	5.250	2.500	3.875	4	17/32	1.125	5/8	11	0.750
1 1/2	1.938	6.125	2.875	4.500	4	21/32	1.313	3/4	10	0.875
2	1.750	6.500	3.625	5.000	8	17/32	1.125	5/8	11	0.750
2 1/2	2.000	7.500	4.125	5.875	8	21/32	1.313	3/4	10	0.875
3	2.000	8.250	5.000	6.625	8	21/32	1.313	3/4	10	0.875
3 1/2	2.125	9.000	5.500	7.250	8	49/64	1.438	7/8	9	1.000
4	2.125	10.750	6.188	8.500	8	49/64	1.438	7/8	9	1.000
5	2.250	13.000	7.313	10.500	8	7/8	1.563	1	8	1.125
6	2.250	14.000	8.500	11.500	12	7/8	1.563	1	8	1.125
8	2.500	16.500	10.625	13.750	12	1	1.813	1 1/8	8	1.250
10	2.750	20.000	12.750	17.000	16	1 1/8	2.125	1 1/4	8	1.438
12	2.750	22.000	15.000	19.250	20	1 1/8	2.125	1 1/4	8	1.438

CLASS 900										
SIZE BORE	FLANGE THCK	OUTER DIAMETER	RAISED FACE	BOLT CIRCLE	NO. OF HOLES	HOLE SIZE	HOLE DEPTH	STUD BOLT		
								THRD SIZE	T.P.I.	THRD DEPTH
1/2	2.000	4.750	1.375	3.250	4	21/32	1.313	3/4	10	0.875
3/4	2.000	5.125	1.688	3.500	4	21/32	1.313	3/4	10	0.875
1	2.125	5.875	2.000	4.000	4	49/64	1.438	7/8	9	1.000
1 1/4	2.125	6.250	2.500	4.375	4	49/64	1.438	7/8	9	1.000
1 1/2	2.250	7.000	2.875	4.875	4	7/8	1.563	1	8	1.125
2	2.125	8.500	3.625	6.500	8	49/64	1.438	7/8	9	1.000
2 1/2	2.250	9.625	4.125	7.500	8	7/8	1.563	1	8	1.125
3	2.125	9.500	5.000	7.500	8	49/64	1.438	7/8	9	1.000
4	2.500	11.500	6.188	9.250	8	1	1.813	1 1/8	8	1.250
5	2.750	13.750	7.313	11.000	8	1 1/8	2.125	1 1/4	8	1.438
6	2.500	15.000	8.500	12.500	12	1	1.813	1 1/8	8	1.250
8	3.000	18.500	10.625	15.500	12	1 1/4	2.250	1 3/8	8	1.563
10	3.000	21.500	12.750	18.500	16	1 1/4	2.250	1 3/8	8	1.563
12	3.000	24.000	15.000	21.000	20	1 1/4	2.250	1 3/8	8	1.563

CLASS 1500										
SIZE BORE	FLANGE THCK	OUTER DIAMETER	RAISED FACE	BOLT CIRCLE	NO. OF HOLES	HOLE SIZE	HOLE DEPTH	STUD BOLT		
								THRD SIZE	T.P.I.	THRD DEPTH
1/2	2.000	4.750	1.375	3.250	4	21/32	1.313	3/4	10	0.875
3/4	2.000	5.125	1.688	3.500	4	21/32	1.313	3/4	10	0.875
1	2.125	5.875	2.000	4.000	4	49/64	1.438	7/8	9	1.000
1 1/4	2.125	6.250	2.500	4.375	4	49/64	1.438	7/8	9	1.000
1 1/2	2.250	7.000	2.875	4.875	4	7/8	1.563	1	8	1.125
2	2.125	8.500	3.625	6.500	8	49/64	1.438	7/8	9	1.000
2 1/2	2.250	9.625	4.125	7.500	8	7/8	1.563	1	8	1.125
3	2.500	10.500	5.000	8.000	8	1	1.813	1 1/8	8	1.250
4	2.750	12.250	6.188	9.500	8	1 1/8	2.125	1 1/4	8	1.438
5	3.125	14.750	7.313	11.500	8	1 3/8	2.375	1 1/2	8	1.688
6	3.000	15.500	8.500	12.500	12	1 1/4	2.250	1 3/8	8	1.563
8	3.500	19.000	10.625	15.500	12	1 1/2	2.563	1 5/8	8	1.875
10	3.875	23.000	12.750	19.000	12	1 3/4	3.000	1 7/8	8	2.125
12	4.125	26.500	15.000	22.500	16	1 7/8	3.313	2	8	2.250

CLASS 2500										
SIZE BORE	FLANGE THCK	OUTER DIAMETER	RAISED FACE	BOLT CIRCLE	NO. OF HOLES	HOLE SIZE	HOLE DEPTH	STUD BOLT		
								THRD SIZE	T.P.I.	THRD DEPTH
1/2	2.000	5.250	1.375	3.500	4	21/32	1.313	3/4	10	0.875
3/4	2.000	5.500	1.688	3.750	4	21/32	1.313	3/4	10	0.875
1	2.125	6.250	2.000	4.250	4	49/64	1.438	7/8	9	1.000
1 1/4	2.250	7.250	2.500	5.125	4	7/8	1.563	1	8	1.125
1 1/2	2.500	8.000	2.875	5.750	4	1	1.813	1 1/8	8	1.250
2	2.250	9.250	3.625	6.750	8	7/8	1.563	1	8	1.125
2 1/2	2.500	10.500	4.125	7.750	8	1	1.813	1 1/8	8	1.250
3	2.750	12.000	5.000	9.000	8	1 1/8	2.125	1 1/4	8	1.438
4	3.250	14.000	6.188	10.750	8	1 3/8	2.375	1 1/2	8	1.688
5	3.750	16.500	7.313	12.750	8	1 5/8	2.813	1 3/4	8	2.000
6	4.125	19.000	8.500	14.500	8	1 7/8	3.313	2	8	2.250
8	4.375	21.750	10.625	17.250	12	1 7/8	3.313	2	8	2.250
10	5.125	26.500	12.750	21.250	12	2 3/8	4.000	2 1/2	8	2.813
12	5.500	30.000	15.000	24.375	12	2 5/8	4.375	2 3/4	8	3.125

# Radiographic & Gamma Plugs

## dimensions

Complies with PFI ES-16

www.woihouston.com

WELDING OUTLETS, INC.

Phone: 281.590.0190 • Fax: 281.590.1415 • 24 Hour: 1.888.610.0777  
ISO 9001:2008 & PED certified - Canadian registered in all provinces.

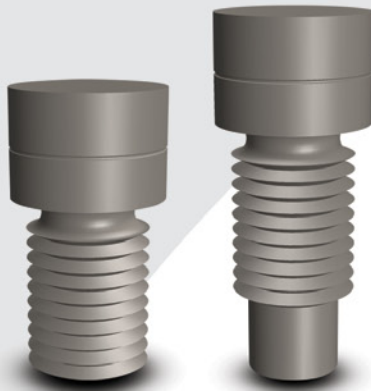

**Dimensions:** PFI ES-16  
**Sizes:** 3/8" thru 2"  
**Materials:** All material grades

PIPE WALL THICKNESS	RADIOGRAPHIC PLUGS					
	STYLE	A	B	B	D	H
< 0.625 (NO BOSS)	1	1.25	N/A	1 - 8UNC - 3A	N/A	0.625
< 0.625 (WITH BOSS)	2	1.25	1.00	1 - 8UNC - 3A	0.812	CUSTOMER SPECIFY
0.625 - 1.375	1	1.25	N/A	1 - 8UNC - 3A	N/A	
1.376 - 3.000	2	1.25	1.25	1 - 8UNC - 3A	0.812	
3.001 - 5.000	2	1.75	1.50	1 - 1/2 - 6UNC - 3A	1.234	
> 5.000	2	2.25	2.00	2 - 4 - 1/2UNC - 3A	1.656	

Dimensions are IAW PFI Standard ES-16

**Radiographic Plug Style 1**

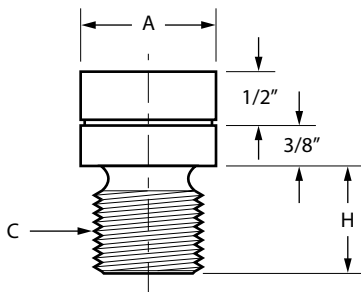

**Radiographic Plug Style 2**

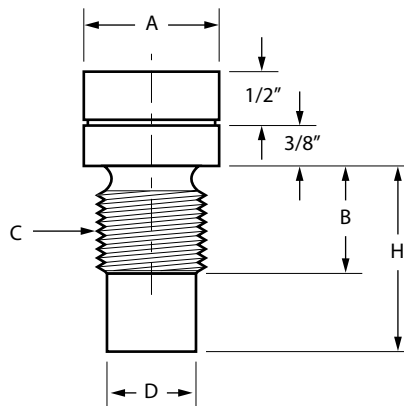

**RT Box in ACC with PFI ES**

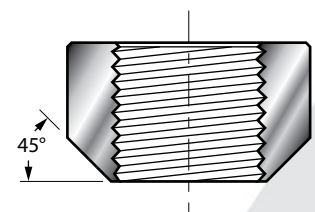

Note: For pipe wall thickness less than 0.625

# Industry Terms

## Alloy Steel

Steel containing significant quantities of alloying elements (other than carbon and the commonly accepted amounts of manganese, silicon, sulfur, and phosphorus) added to effect changes in the mechanical or physical properties.

## Brinell Hardness Test

A test for determining the hardness of a material by forcing a hard steel or carbide ball of specified diameter into it under a specified load.

## Charpy Impact Test

A pendulum-type single-blow impact test in which the specimen, usually notched, is supported at both ends as a simple beam and broken by a falling pendulum. The energy absorbed, as determined by the subsequent rise of the pendulum, is a measure of impact strength or notch toughness.

## Check Analysis

An analysis of the metal after it has been rolled or forged into semi-finished or finished forms. It is not a check on the ladle analysis, but is a check against the chemistry ordered, i.e. Product Analysis.

## Dye Penetrant Inspection

Non-destructive test employing dye or fluorescent chemical and sometimes black light to detect surface defects.

## Elongation

The amount of permanent stretch, usually referring to a measurement of a specimen after fracture is a tensile test. It is expressed as a percentage of the original gauge length.

## Hardness

A measure of the degree of a material's resistance to indentation. It is usually determined by measuring resistance to penetration, by such tests as Brinell, Rockwell, and Vickers.

## Heat

A Generic term denoting a specific lot of steel, based upon a steel making and casting consideration.

## Heat-Affected Zone

That portion of the base metal which was not melted during brazing, cutting, or welding, but whose microstructure and physical properties were altered by the heat.

## Heat Analysis

The Chemical Analysis determined by the steel producer as being representative of a specific heat of steel.

## Heat Number

The alpha, numeric, or alphanumeric designator used to identify a specific heat of steel.

## Heat Treatment

Heating and cooling a steel object in such a way as to obtain desired conditions or properties.

## Inspection

The Process of measuring, examining, testing, gauging, or otherwise comparing the unit of product with the applicable requirements.  
Ladle Analysis: Chemical analysis obtained from a sample taken during the pouring of steel, i.e. heat analysis.

## Lap

A surface defect, appearing as a seam, caused by folding over hot metal, fins, or sharp corners and then rolling or forging them into the surface, but not welding them.

## Magnetic-Particle Inspection

A nondestructive method of inspection for determining the existence and extent of possible defects in ferromagnetic materials. Finely divided magnetic particles, applied to the magnetized part, are attracted to and outline the pattern of any magnetic-leakage fields created by discontinuities.

## Manufacturer

The organization responsible for the conversion of materials into products meeting the requirements of a product specification.

## Quenching

Rapid Cooling.

## Reduction of Area

(1) Commonly, the difference, expressed as a percentage of original area, between the original cross-sectional area of a tensile test specimen and the minimum cross-sectional area measured after complete separation.  
(2) The difference, expressed as a percentage of original area, between original cross-sectional area and that after straining the specimen.

## Solution Anneal

Heating steel into a temperature range wherein certain elements or compounds dissolve, followed by cooling at a rate sufficient to maintain these elements in solution at room temperature. The expression is normally applied to stainless and other special steels.

## Stabilizing Treatment

Any treatment intended to stabilize the structure of an alloy of the dimensions of a part. Heating austenitic stainless steels that contain titanium, columbium, or tantalum to a suitable temperature below that of a full anneal in order to inactivate the maximum amount of carbon by precipitation as a carbide of titanium, columbium, or tantalum.

## Stainless Steel

A Steel that conforms to a specification that requires, by mass percent, a minimum chromium content of 10.5 or more, and a maximum carbon content of less than 1.20.

## Steel

A material that conforms to a specification that requires, by mass percent more iron than any other element and a maximum carbon content of generally less than 2.

## Tensile Strength

In tensile strength, the ratio of maximum load to original cross-sectional area. Also called ultimate strength.

## Ultrasonic Testing

The method of detecting defects or welds by passing high-frequency sound waves into a material, then monitoring and evaluating the reflected signals.

## Yield Strength

The stress at which a material exhibits a specified deviation from proportionality of stress. An offset of 0.2% is used for many materials.

# Pipe Sizes & Schedules

PIPE SIZE	O.D. IN INCHES	PIPE SCHEDULES													
		5	10	20	30	STD.	40	60	xs	80	100	120	140	160	xxs
1/8	.405	-	.049	-	.057	.068	.068	-	.095	.095	-	-	-	-	-
		-	.188	-	.2118	.2447	.2447	-	.3145	.3145	-	-	-	-	-
		-	.307	-	.291	.269	.269	-	.215	.215	-	-	-	-	-
1/4	.540	-	.065	-	.073	.088	.088	-	.119	.119	-	-	-	-	-
		-	.3297	-	.364	.4248	.4248	-	.5351	.5351	-	-	-	-	-
		-	.410	-	.394	.364	.364	-	.302	.302	-	-	-	-	-
3/8	.675	-	.065	-	.073	.091	.091	-	.126	.126	-	-	-	-	-
		-	.4235	-	.4693	.5676	.5676	-	.7388	.7388	-	-	-	-	-
		-	.545	-	.529	.493	.493	-	.423	.423	-	-	-	-	-
1/2	.840	.065	.083	-	.095	.109	.109	-	.147	.147	-	-	-	.188	.294
		.5380	.6710	-	.7559	.8510	.8510	-	1.088	1.088	-	-	-	1.309	1.714
		.710	.674	-	.650	.622	.622	-	.546	.546	-	-	-	.464	.252
3/4	1.050	.065	.083	-	.095	.113	.113	-	.154	.154	-	-	-	.219	.308
		.6838	.8572	-	.9689	1.131	1.131	-	1.474	1.474	-	-	-	1.944	2.441
		.920	.884	-	.860	.824	.824	-	.742	.742	-	-	-	.612	.434
1"	1.315	.065	.109	-	.114	.133	.133	-	.179	.179	-	-	-	.250	.358
		.8678	.1404	-	1.462	1.679	1.679	-	2.172	2.172	-	-	-	2.844	3.659
		1.185	1.097	-	1.087	1.049	1.049	-	.957	.957	-	-	-	.814	.599
1-1/4	1.660	.065	.109	-	.117	.140	.140	-	.191	.191	-	-	-	.250	.382
		1.107	1.806	-	1.928	2.273	2.273	-	2.997	2.997	-	-	-	3.765	5.214
		1.530	1.442	-	1.426	1.380	1.380	-	1.278	1.278	-	-	-	1.160	.896
1-1/2	1.900	.065	.109	-	.125	.145	.145	-	.200	.200	-	-	-	.281	.400
		1.274	2.085	-	2.370	2.718	2.718	-	3.631	3.631	-	-	-	4.859	6.408
		1.77	1.682	-	1.650	1.610	1.610	-	1.500	1.500	-	-	-	1.338	1.100
2"	2.375	.065	.109	-	.125	.154	.154	-	.218	.218	-	-	-	.344	.436
		1.604	2.638	-	3.004	3.653	3.653	-	5.022	5.022	-	-	-	7.462	9.029
		2.245	2.157	-	2.125	2.067	2.067	-	1.939	1.939	-	-	-	1.687	1.503
2-1/2	2.875	.083	.120	-	.188	.203	.203	-	.276	.276	-	-	-	.375	.552
		2.475	3.531	-	5.395	5.793	5.793	-	7.661	7.661	-	-	-	10.01	13.69
		2.709	2.635	-	2.499	2.469	2.469	-	2.323	2.323	-	-	-	2.125	1.771
3"	3.5	.083	.120	-	.188	.216	.216	-	.300	.300	-	-	-	.438	.600
		3.029	4.332	-	6.650	7.576	7.576	-	10.25	10.25	-	-	-	14.32	18.58
		3.334	3.260	-	3.124	3.068	3.068	-	2.90	2.90	-	-	-	2.624	2.30
3-1/2	4.0	.083	.120	-	.188	.226	.226	-	.318	.318	-	-	-	-	-
		3.472	4.973	-	7.654	9.109	9.109	-	12.50	12.50	-	-	-	-	-
		3.834	3.76	-	3.624	3.548	3.548	-	3.364	3.364	-	-	-	-	-
4"	4.5	.083	.120	-	.188	.237	.237	.281	.337	.337	-	.438	-	.531	.674
		3.915	5.613	-	8.658	10.79	10.79	12.66	14.98	14.98	-	19.00	-	22.51	27.54
		4.334	4.260	-	4.124	4.026	4.026	3.938	3.826	3.826	-	3.624	-	3.438	3.152
5"	5.563	.109	.134	-	-	.258	.258	-	.375	.375	-	.500	-	.625	.750
		6.349	7.770	-	-	14.62	14.62	-	20.78	20.78	-	27.04	-	32.96	38.55
		5.345	5.295	-	-	5.047	5.047	-	4.813	4.813	-	4.563	-	4.313	4.063
6"	6.625	.109	.134	-	-	.280	.280	-	.432	.432	-	.562	-	.719	.864
		7.585	9.289	-	-	18.97	18.97	-	28.57	28.57	-	36.39	-	45.35	53.16
		6.407	6.357	-	-	6.065	6.065	-	5.761	5.761	-	5.501	-	5.187	4.897
8"	8.625	.109	.148	-	.277	.322	.322	.406	.500	.500	.594	.719	.812	.906	.875
		9.914	13.40	-	24.70	28.55	28.55	35.64	43.39	43.39	50.95	60.71	67.76	74.69	72.424
		8.407	8.329	-	8.071	7.981	7.981	7.813	7.625	7.625	7.437	7.187	7.001	6.813	6.875
10"	10.75	.134	.165	.250	.307	.365	.365	.500	.500	.594	.719	.844	1.000	1.125	1.000
		15.19	18.653	28.04	34.24	40.48	40.48	54.74	54.74	64.429	77.027	89.292	104.13	115.64	104.13
		10.482	10.42	10.25	10.136	10.02	10.02	9.75	9.75	9.562	9.312	9.062	8.75	8.500	8.75
12"	12.75	.156	.180	.250	.330	.375	.406	.562	.500	.688	.844	1.000	1.125	1.312	1.000
		20.98	24.17	33.38	43.77	49.56	53.52	73.15	65.42	88.63	107.32	125.5	139.67	160.27	125.5
		12.438	12.390	12.25	12.09	12.00	11.938	11.626	11.75	11.374	11.062	10.75	10.50	10.126	10.75
14"	14.0	.156	.250	.312	.375	.375	.438	.594	.500	.750	.938	1.094	1.250	1.406	-
		23.07	36.71	45.61	54.57	54.57	63.44	85.05	72.09	106.13	130.85	150.79	170.21	189.11	-
		13.688	13.50	13.376	13.25	13.25	13.124	12.812	13.00	12.50	12.124	11.812	11.500	11.188	-
16"	16.0	.165	.250	.312	.375	.375	.500	.656	.500	.844	1.031	1.219	1.438	1.594	-
		27.90	42.05	52.27	62.58	62.58	82.77	107.5	82.77	136.61	164.82	192.43	223.64	245.25	-
		15.67	15.50	15.376	15.25	15.25	15.00	14.688	15.00	14.312	13.938	13.562	13.124	12.812	-
18"	18.0	.165	.250	.312	.438	.375	.562	.750	.500	.938	1.156	1.375	1.562	1.781	-
		31.43	47.39	58.94	82.15	70.59	104.67	138.17	93.45	170.92	207.96	244.14	274.22	308.5	-
		17.67	17.50	17.376	17.124	17.25	16.876	16.50	17.00	16.124	15.688	15.25	14.876	14.438	-
20"	20.0	.188	.250	.375	.500	.375	.594	.812	.500	1.031	1.281	1.500	1.75	1.969	-
		39.78	52.73	78.60	104.13	78.60	123.11	166.40	104.13	208.87	256.10	296.37	341.09	379.17	-
		19.624	19.50	19.25	19.00	19.25	18.812	18.376	19.00	17.938	17.438	17.00	16.50	16.062	-
24"	24.0	.218	.250	.375	.562	.375	.688	.969	.500	1.219	1.531	1.812	2.062	2.344	-
		55.37	63.41	94.62	140.8	94.62	171.29	238.35	125.5	296.58	367.39	429.39	483.12	542.13	-
		23.564	23.50	23.25	22.876	23.25	22.624	22.062	23.00	21.562	20.938	20.376	19.876	19.312	-

# Wall Thickness

PIPE SIZE	PIPE SCHEDULES													
	5	10	20	30	STD*	40	60	XS †	80	100	120	140	160	XXS
1/8"	-	0.049	-	0.057	0.068	0.068	-	0.095	0.095	-	-	-	0.124	0.190
1/4"	-	0.065	-	0.073	0.088	0.088	-	0.119	0.119	-	-	-	0.145	0.238
3/8"	-	0.065	-	0.073	0.091	0.091	-	0.126	0.126	-	-	-	0.158	0.252
1/2"	0.065	0.083	-	0.095	0.109	0.109	-	0.147	0.147	-	-	-	0.188	0.294
3/4"	0.065	0.083	-	0.095	0.113	0.113	-	0.154	0.154	-	-	-	0.219	0.308
1"	0.065	0.109	-	0.114	0.133	0.133	-	0.179	0.179	-	-	-	0.250	0.358
1-1/4"	0.065	0.109	-	0.117	0.140	0.140	-	0.191	0.191	-	-	-	0.250	0.382
1-1/2"	0.065	0.109	-	0.125	0.145	0.145	-	0.200	0.200	-	-	-	0.281	0.400
2"	0.065	0.109	-	0.125	0.154	0.154	-	0.218	0.218	-	-	-	0.344	0.436
2-1/2"	0.083	0.120	-	0.188	0.203	0.203	-	0.276	0.276	-	-	-	0.375	0.552
3"	0.083	0.120	-	0.188	0.216	0.216	-	0.300	0.300	-	-	-	0.438	0.600
3-1/2"	0.083	0.120	-	0.188	0.226	0.226	-	0.318	0.318	-	-	-	-	0.636
4"	0.083	0.120	-	0.188	0.237	0.237	-	0.337	0.337	-	0.438	-	0.531	0.674
5"	0.109	0.134	-	-	0.258	0.258	-	0.375	0.375	-	0.500	-	0.625	0.750
6"	0.109	0.134	-	-	0.280	0.280	-	0.432	0.432	-	0.562	-	0.719	0.864
8"	0.109	0.148	0.250	0.277	0.322	0.322	0.406	0.500	0.500	0.594	0.719	0.812	0.906	0.875
10"	0.134	0.165	0.250	0.307	0.365	0.365	0.500	0.500	0.594	0.719	0.844	1.000	1.125	1.000
12"	0.156	0.180	0.250	0.330	0.375	0.406	0.562	0.500	0.688	0.844	1.000	1.125	1.312	1.000
14"	0.156	Δ 0.250	0.312	0.375	0.375	0.438	0.594	0.500	0.750	0.938	1.094	1.250	1.406	-
16"	0.165	Δ 0.250	0.312	0.375	0.375	0.500	0.656	0.500	0.844	1.031	1.219	1.438	1.594	-
18"	0.165	Δ 0.250	0.312	0.438	0.375	0.562	0.750	0.500	0.938	1.156	1.375	1.562	1.781	-
20"	0.188	Δ 0.250	0.375	0.500	0.375	0.594	0.812	0.500	1.031	1.281	1.500	1.750	1.969	-
22"	0.188	Δ 0.250	0.375	0.500	0.375	-	0.875	0.500	1.125	1.375	1.625	1.875	2.125	-
24"	0.218	0.250	0.375	0.562	0.375	0.688	0.969	0.500	1.219	1.531	1.812	2.062	2.344	-
26"	-	0.312	0.500	-	0.375	-	-	0.500	-	-	-	-	-	-
30"	0.250	0.312	0.500	0.625	0.375	-	-	0.500	-	-	-	-	-	-
34"	-	0.312	0.500	0.625	0.375	0.688	-	0.500	-	-	-	-	-	-
36"	-	0.312	0.500	0.625	0.375	0.750	-	0.500	-	-	-	-	-	-
42"	-	-	-	-	0.375	-	-	0.500	-	-	-	-	-	-
48"	-	-	-	-	0.375	-	-	0.500	-	-	-	-	-	-

All dimensions are given in inches and are in accordance with ASME B36.10 or ANSI/ASME B36.19 as applicable. The decimal thickness listed for the pipe sizes represent their nominal or average wall dimensions.

\* For nominal sizes thru 10", Standard Weight thicknesses are identical to Schedule 40 thicknesses.  
 † For nominal sizes thru 8", Extra Strong thicknesses are identical to Schedule 80 thicknesses.  
 Δ These do not conform to ANSI/ASME B36.19.

# Bore Chart (I.D. of Pipe)

PIPE SIZE	O.D. IN INCHES	PIPE SCHEDULES													
		5	10	20	30	40	60	80	100	120	140	160	STD.	XS	XXS
1/8"	0.405	-	0.307	-	0.291	0.269	-	0.215	-	-	-	0.157	0.269	0.215	0.025
1/4"	0.540	-	0.410	-	0.394	0.364	-	0.302	-	-	-	0.250	0.364	0.302	0.064
3/8"	0.675	-	0.545	-	0.529	0.493	-	0.423	-	-	-	0.359	0.493	0.423	0.171
1/2"	0.840	0.710	0.674	-	0.650	0.622	-	0.546	-	-	-	0.464	0.622	0.546	0.252
3/4"	1.050	0.920	0.884	-	0.860	0.824	-	0.742	-	-	-	0.612	0.824	0.742	0.434
1"	1.315	1.185	1.097	-	1.087	1.049	-	0.957	-	-	-	0.815	1.049	0.957	0.599
1-1/4"	1.660	1.530	1.442	-	1.426	1.380	-	1.278	-	-	-	1.160	1.380	1.278	0.896
1-1/2"	1.900	1.770	1.682	-	1.650	1.610	-	1.500	-	-	-	1.338	1.610	1.500	1.10
2"	2.375	2.245	2.157	-	2.125	2.067	-	1.939	-	-	-	1.687	2.067	1.939	1.503
2-1/8"	2.875	2.709	2.635	-	2.499	2.469	-	2.323	-	-	-	2.125	2.469	2.323	1.771
3"	3.500	3.334	3.260	-	3.124	3.068	-	2.900	-	-	-	2.624	3.068	2.900	2.300
3-1/2"	4.000	3.834	3.760	-	3.624	3.548	-	3.364	-	-	-	-	3.548	3.364	2.728
4"	4.500	4.334	4.260	-	4.124	4.026	-	3.826	-	3.624	-	3.438	4.026	3.826	3.152
5"	5.563	5.345	5.295	-	-	5.047	-	4.813	-	4.563	-	4.313	5.047	4.813	4.063
6"	6.625	6.407	6.357	-	-	6.065	-	5.761	-	5.501	-	5.187	6.065	5.761	4.897
8"	8.625	8.407	8.329	8.125	8.071	7.981	7.813	7.625	7.437	7.187	7.001	6.813	7.981	7.625	6.875
10"	10.750	10.482	10.420	10.250	10.136	10.020	9.750	9.562	9.312	9.062	8.750	8.500	10.020	9.750	8.750
12"	12.750	12.438	12.390	12.250	12.090	11.938	11.626	11.374	11.062	10.750	10.500	10.126	12.000	11.750	10.750
14"	14.000	13.688	13.500	13.376	13.250	13.124	12.812	12.500	12.124	11.812	11.500	11.188	13.250	13.000	-
16"	16.000	15.670	15.500	15.376	15.250	15.000	14.688	14.312	13.938	13.562	13.124	12.812	15.250	15.000	-
18"	18.000	17.670	17.500	17.376	17.124	16.876	16.500	16.124	15.688	15.250	14.876	14.438	17.250	17.000	-
20"	20.000	19.624	19.500	19.250	19.000	18.812	18.376	17.938	17.438	17.000	16.500	16.062	19.250	19.000	-
24"	24.000	23.564	23.500	23.250	22.876	22.624	22.062	21.562	20.938	20.376	19.876	19.312	23.250	23.000	-
30"	30.000	29.500	29.376	29.000	28.750	-	-	-	-	-	-	-	29.250	29.000	-

To be used as a guide only. Above data was compiled from existing standards.

# Tap & Drill Sizes

N.C. OR U.S.S. STD. SCREW THRDS			MACHINE SCREWS			N.P.T. PIPE THREADS			N.F. OR S.A.E. STD. SCREW THRDS		
TAP	DRILL SIZE		TAP	DRILL SIZE		TAP	DRILL SIZE		TAP	DRILL SIZE	
1/4 - 20	7	.2010	2 - 56	50	.0700	1/8 - 27	Q	.332	1/4 - 28	3	.213
5/16 - 18	F	.2570	3 - 48	47	.0785	1/4 - 18	7/16	T A P E R P E R F T. 3/4"	5/16 - 24	I	.272
3/8 - 16	5/16	.3125	4 - 32	45	.0820	3/8 - 18	9/16		3/8 - 24	Q	.332
7/16 - 14	U	.3680	4 - 36	44	.0860	1/2 - 14	45/64		7/16 - 20	25/64	.3906
1/2 - 13	27/64	.4219	4 - 40	43	.0890	3/4 - 14	29/32		1/2 - 20	29/64	.4531
9/16 - 12	31/64	.4844	6 - 32	36	.1065	1 - 11-1/2	1-9/64		9/16 - 18	33/64	.5156
5/8 - 11	17/32	.5312	8 - 32	29	.1360	1-1/4 - 11-1/2	1-31/64		5/8 - 18	37/64	.5781
3/4 - 10	21/32	.6562	10 - 24	25	.1495	11/2-111/2	1-23/32		3/4 - 16	11/16	.6875
7/8 - 9	49/64	.7656	10 - 32	21	.1590	2-11-1/2	2-3/16		7/8 - 14	13/16	.8125
1 - 8	7/8	.8750	12 - 24	16	.1770	2-1/2 - 8	2-39/64		1 - 14	15/16	.9375
11/8 - 7	63/64	.9844	14 - 20	10	.1935	3 - 8	3-1/4		1-1/8 - 12	13/64	1.0469

# Fractions to Decimals

1/64 = .0156	9/64 = .1406	17/64 = .2656	25/64 = .3906	33/64 = .5156	41/64 = .6406	49/64 = .7656	57/64 = .8906
1/32 = .0312	5/32 = .1562	9/32 = .2812	13/32 = .4062	17/32 = .5312	21/32 = .6562	25/32 = .7812	29/32 = .9062
3/64 = .0469	11/64 = .1719	19/64 = .2969	27/64 = .4219	35/64 = .5469	43/64 = .6719	51/64 = .7969	59/64 = .9219
1/16 = .0625	3/16 = .1875	5/16 = .3125	7/16 = .4375	9/16 = .5625	11/16 = .6875	13/16 = .8125	15/16 = .9375
5/64 = .0781	13/64 = .2031	21/64 = .3281	29/64 = .4531	37/64 = .5781	45/64 = .7031	53/64 = .8281	61/64 = .9531
3/32 = .0937	7/32 = .2187	11/32 = .3437	15/32 = .4687	19/32 = .5937	23/32 = .7187	27/32 = .8437	31/32 = .9687
7/64 = .1094	15/64 = .2344	23/64 = .3594	31/64 = .4844	39/64 = .6094	47/64 = .7344	55/64 = .8594	63/64 = .9844
1/8 = .1250	1/4 = .2500	3/8 = .3750	1/2 = .5000	5/8 = .6250	3/4 = .7500	7/8 = .8750	1.000

# Measurement Conversions

Feet	0.3048 Meter
Kilometers	3280.84 Feet
Kilogram	(2.20462#)
Meter	39.3701 Inches
Meter	3.28 Feet
Meter	0.001 Kilometer
Meter	1.0936 Yards
Millimeter	0.03937 Inches
Pound	X 0.4536 = Kilograms
Square Meter	10.7639 SQ. FT.
Ton (Short)	200# = 907.18 Kilograms
Yards	0.9144 Meter
Square Inscribed in Circle	= Side of Square = Dia. of Circle x.7071
Wt. of Mat'l OD 2 x 0.233	= wt/Inch x 12 = wt #FT

# Nominal Sizes

MM SIZE	NPS
15	1/2
20	3/4
25	1
40	1 1/2
50	2
80	3
100	4
150	6
200	8
250	10
300	12
350	14
400	16
450	18
500	20
600	24
750	30
900	36
1050	42
1200	48

# Codes & Standards

## ASME

- B1.20.1 - Pipe Threads, General Purpose (Inch)
- B16.5 - Pipe Flanges & Flanged Fittings
- B16.9 - Factory - Made Wrought Butt-Welding Fittings
- B16.11 - Forged Fittings, Socket-Welding & Threaded
- B16.25 - Butt-Welding Ends
- B16.47 - Large Diameter Steel, Flanges (NPS 26 Thru NPS 60)
- B31.1 - Power Piping
- B31.3 - Process Piping
- B31.4 - Pipeline Transportation Systems for Liquid Hydrocarbons and other Liquids.
- B31.8 - Gas Transmission & Distribution Piping Systems
- B31.9 - Building Services Piping
- B36.19M - Stainless Steel Pipe

## PFI: Pipe Fabrication Institute - Engineering & Fabrication Standards

- ES-1 - Internal Machining Backing Rings
- ES-16 - Access Holes, Bosses, Plugs, for RT Inspection of Pipe Welds
- ES-36 - Branch Reinforcement
- ES-42 - PMI STD.

## NACE STD

- MR0175 Material Requirements (For Resistance To Sulfide Stress Cracking, BHN / HRC)

## ASTM International

- A262-Intergranular Test, Austenitic Stainless
- A275-Magnetic Particle Exam.
- A370-Mechanical (Tensile) Test Steel Products
- A388-Ultrasonic Exam: Steel Forgings
- A751-Chemical Analysis of Steel Products
- E-10-Test Brinell. Hardness
- E23-Standard Notch Bar Impact Test
- E112-Test-Grain Size
- E165-Liquid Penetrant Exam.
- E562-Test Method Determining Volume Fraction By Manual Point Count

## MSS - STD

- SP-25 - Marking Valves, Fittings, Flanges, & Unions
- SP-42 - Stainless Butt-Weld Fittings
- SP-44 - Steel Pipeline Flanges 12" - 60" F36 - F70
- SP-75 - High-Test Butt-Weld Fittings
- SP-79 - Socket-Welding Reducer Inserts
- SP-83 - Class 3000 Steel Pipe Unions
- SP-95 - Swages & Bull Plugs
- SP-97 - Branch Outlet Fittings, Socket Weld, Threaded, Butt Weld

## Wrought

Metal in the solid condition that is formed to a desired shape by working (Rolling, Extruding, Forging, etc.) usually at an elevated temperature.

## Forge

Plastically deforming metal, usually hot, into desired shapes with compressive force, with or without dies.

## Cast Component

Metal that is obtained at or near its finished shaped by (Casting) solidification of molten metals in a mold.

# Certifications & Registrations

## Global Certifications

- ISO 9001:2008 (Certified by HBS Registration Services)
- PED (Certified by Hartford Steamboiler Internationals GmbH)

## US Standards & Memberships

- WBENC (Certified by the WBENC & WBNA)
- HUB (Certified by the State of Texas)
- Pipe Fabrication Institute Member
- MSS Manufacturers Standardization Society

## Canadian Registration Numbers

**ACI Central, Inc., TSSA, CSA and ABSA have forwarded to Welding Outlets Inc. the following Product Approvals and CRN's:**

### CRN's for Category A-Pipe Fittings

New Brunswick	CRN 0A0952.97A.2
New Foundland & Labrador	CRN 0A0952.90 A.2
Northwest Territories	CRN 0A0952.9TA.2
Nova Scotia	CRN 00A952.98A.2
Nunavut	CRN 0A0952.9N.A.2
Prince Edward Islands	CRN 0A0952.9
Yukon Territories	CRN 0A0952.9Y
Ontario	CRN CSA-0A0952.95A2
Alberta	CRN 0A0952.92
British Columbia	CRN 0A0952.951
Quebec	CRN CSA-0A0952.96A2
Saskatchewan	CRN CSA-0A0952.96A2
Manitoba	CRN CSA-0A0952.96A2

### CRN's for Category B-Flanges

New Brunswick	CRN 0B0997.97
New Foundland & Labrador	CRN 0B0997.90
Northwest Territories	CRN 0B0997.9T
Nova Scotia	CRN 0B0997.98
Nunavut	CRN 0B0997.9N
Prince Edward Islands	CRN 0B0997.9
Yukon Territories	CRN 0B0997.9Y
Ontario	CRN CSA-0B0997.96
Alberta	CRN 0B0997.92
British Columbia	CRN 0A0952.95
Quebec	CRN CSA-0B0997.9.951
Saskatchewan	CRN CSA-0B0997.9.951
Manitoba	CRN CSA-0A0997.9.951

# Material Specifications

IDENTIFICATION SYMBOL	UNS#	BAR	FORGINGS	WELD FITTINGS	PIPE	PLATE	ASME WELD
<b>Austenitic Stainless</b>							
304	S30400	A276/479	A182	A403WP	A312	A240	P8
304H	S30409	A276/479	A182	A403WP	A312	A240	P8
304L	S30403	A276/479	A182	A403WP	A312	A240	P8
316	S31600	A276/479	A182	A403WP	A312	A240	P8
316H	S31609	A276/479	A182	A403WP	A312	A240	P8
316L	S31603	A276/479	A182	A403WP	A312	A240	P8
317L	S31703	A276/479	A182	A403WP	A312	A240	P8
321	S32100	A276/479	A182	A403WP	A312	A240	P8
321H	S32109	A276/479	A182	A403WP	A312	A240	P8
347	S32700	A276/479	A182	A403WP	A312	A240	P8
347H	S34709	A276/479	A182	A403WP	A312	A240	P8
F44 (254SMO)	S31254	A276/479	A182	A403WP	A312	A240	P8
<b>Ferritic-Austenitic Stainless</b>							
F51 (DUPLEX)	S31803	A276/479	A182	A182/A815WP	A790	A240	P10H
F53 (SUPER DUPLEX)	S32750	A479	A182	A182/A815WP	A790	A240	P10H
F55 (ZERON 100)	S32760	A276	A182	A182/A815WP	A790	A240	S-10H
F60	S32205	A276	A182	A182/A815WP	A790	A240	S-10H
F61 FERR: 255	S32550	A276/479	A182	A182/A815WP	A790	A240	10H
<b>Low Alloy Steels</b>							
F5	K41545	A182	A182	A234	A335	A387	P5B
F9	K90941	A182	A182	A234	A335	A387	P5B
F91	K90901	A182	A182	A234	A335	A387	P5B
F11 Class 1	K11597	A182	A182	A234	A335	A387	P4
F11 Class 2 & 3	K11572	A182	A182	A234	A335	A387	P4
F22 Class 1 & 3	K21590	A182	A182	A234	A335	A387	P5A
<b>Carbon-Steel</b>	.	A105/A695	A105	A234	A335	A516	P1
<b>Low-Temperature Steel</b>	.	A350-LF2 CL1	A350-LF2 CL1	A420WPL6	A333GR6	.	P1
<b>High Strength Transmission Service</b>	.	.	A649F42- F70	A860/SP-75	A381/AP1-5L	.	S-1
<b>Nickel Alloys</b>							
Nickel- 200	N02200	B160	B564	B366WPN	B161	B162	P41
Nickel- 400	N04400	B164	B564	B366WPNC	B165	B127	P42
Nickel- 600	N06600	B166	B564	B366WPNC1	B167/B516	B168	P43
Alloy- 625	N06625	B466	B564	B366WPNCMC	B444	B443	P43
Alloys-800H	N08810	B408	B564	B366WPNCICIO	B407	B409	P45
Alloy- 800 HT	N08811	B408	B564	B366WPNCII	B407	B409	P45
Alloy- 825	N08825	B425	B564	B366WPNCMC	B423	B424	P45
<b>Corrosive High Temp. Service</b>							
A20	N08020	B473	B462	B366WP20CB	B729	B463	P45
6 Moly- AL6XN	N08367	B691	B462	B366WP6XN	B690	B688/A240	P45
C276	N10276	B574	B564/B462	B366WPHC276	B619/B622	B575	P44
HAST - B3	N10675	B335	B564/B462	B366WPHB-2	B619/B622	B333	P44
HAST - C22	N06022	B574	B564/B462	B366WPHC22	B619/B622	B575	P44
<b>Titanium</b>							
Grade 2	R50400	B348	B381 F2	B363WPT1	B338	B265	P51
Grade 7	RR52400	B348	B381 F7	B363WPT7	B338	B265	P51
<b>Copper-Nickel</b>	.	Reference MIL-C & MIL-F Standards					.
70-30 (MIL-STD)	C71500						P34
90-10 (MIL-STD)	C770600	.	.	.	.	.	P34
<b>Cr-Mo Alloy Steel</b>							
4130	G41300	A29/A322	A711	A322	A519	A829	.



www.woihouston.com  
Toll Free: (888) 610-0777  
Local: (281) 590-0190